

ICES Techniques in Marine Environmental Sciences

No. 27

Soft bottom macrofauna: Collection, treatment, and quality assurance of samples

H. RUMOHR

Institut für Meereskunde
Düsternbrooker Weg 20
D-24105 Kiel
Germany

International Council for the Exploration of the Sea
Conseil International pour l'Exploration de la Mer

Palægade 2-4 DK-1261 Copenhagen K Denmark

December 1999

ISSN 0903-2606

For permission to reproduce material from *ICES Techniques in Marine Environmental Sciences*, please apply to the General Secretary.

TABLE OF CONTENTS

Section	Page
ABSTRACT	I
1 INTRODUCTION.....	1
2 SAMPLING STRATEGY	1
2.1 Sampling.....	2
2.2 Infauna	2
2.2.1 Box corer sampling.....	2
2.2.2 Grab sampling.....	3
2.2.3 Diver-operated samplers.....	5
2.3 Epifauna.....	6
2.3.1 Dredges and trawls	6
2.3.2 Underwater photography and television.....	7
3 TREATMENT OF SAMPLES	8
3.1 Separation of Fauna from the Sediment.....	8
3.3.1 Sieves.....	8
3.3.2 Sieving procedure.....	8
3.2 Fixation	10
3.2.1 Staining.....	11
3.3 Sieving of Fixed Material	11
3.4 Sorting.....	11
3.5 Biomass Determination.....	12
3.6 Preservation and Storage.....	13
3.7 Reference Collection.....	13
3.8 Determination of Production.....	13
3.9 Integration with Meiofauna Studies.....	13
4 PUBLICATION OF ABUNDANCE AND BIOMASS RESULTS	13
5 STATION DATA.....	14
6 IN-HOUSE QUALITY ASSURANCE	15
7 REFERENCES	16

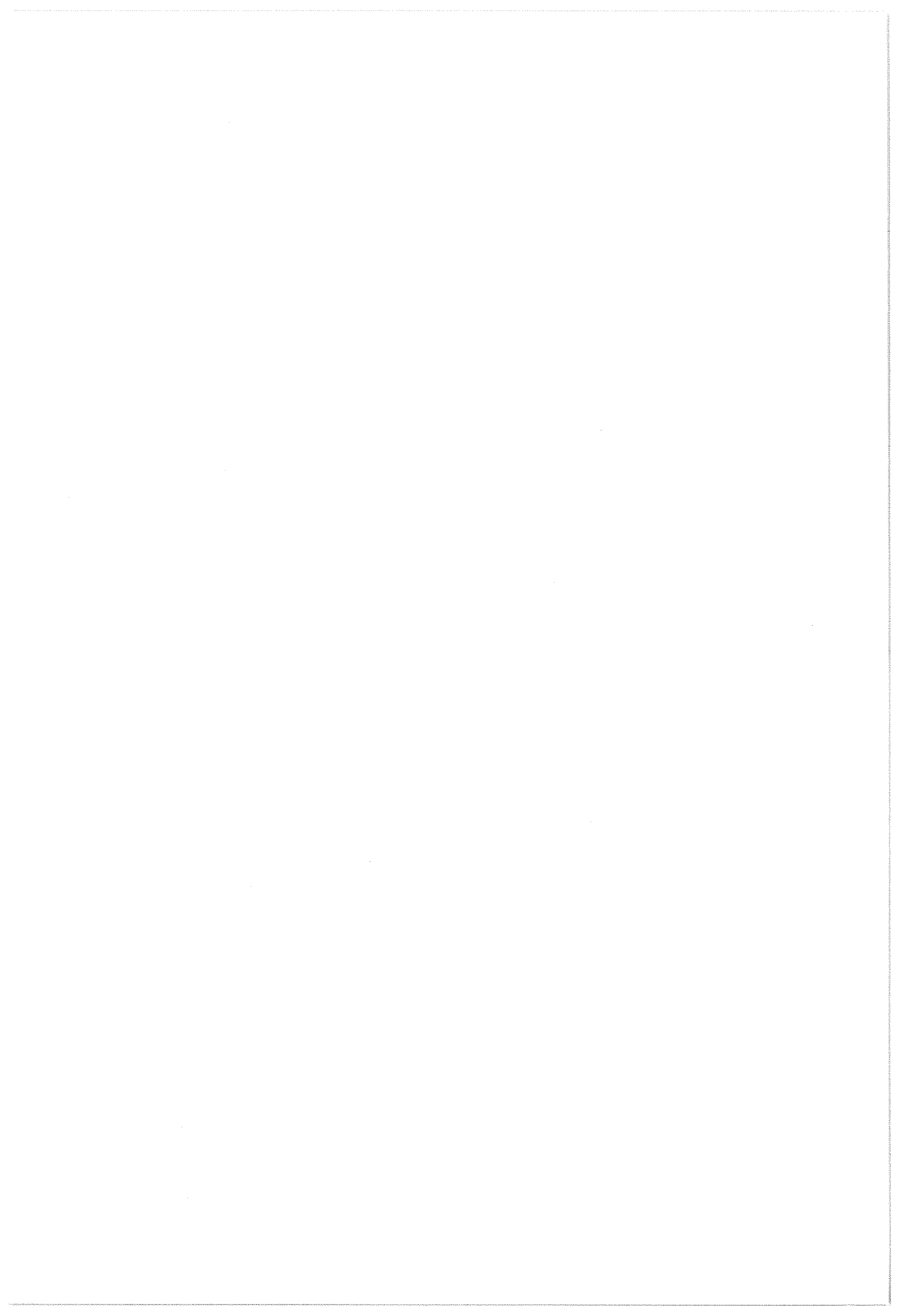

Soft bottom macrofauna: Collection, treatment, and quality assurance of samples

Heye Rumohr

Rumohr, H. 1999. Soft bottom macrofauna: Collection, treatment, and quality assurance of samples. ICES Techniques in Marine Environmental Sciences, No. 27. 19 pp.

Abstract

The aim of these recommendations is to standardize the methods used by different scientists for benthos surveys in order to increase the comparability of results for different areas.

The results of ICES/HELCOM Quality Assurance workshops, intercalibrations, and ring tests have been incorporated in this set of recommendations in order to increase the quality, reliability and, thus, comparability of benthos data at a time when an increasing number of researchers and institutions are engaged in sorting and analysing benthos samples before their final evaluation and the storage of information in public data banks. The choice of an appropriate sampler depends on the average living depth of the infauna in question, which can range from the upper millimetre down to almost one metre. Possible discrepancies between the penetration depth of the sampler and the actual living depth must be considered when analysing the results. This set of recommendations covers all steps from the design of the sampling programme to considerations of which gear to use, and all ship-board methods such as sampling with grabs, corers, dredges, and trawls. There is no single standard sampling gear for benthos investigations. The choice of a suitable sampler is a compromise between specific sampling characteristics in different sediment regimes in the area to be sampled, good handling characteristics at sea in bad weather conditions, suitability for various ships, financial limitations, tradition, and scientific questions. Criteria for the rejection of samples are identified. Treatment of samples is described in detail including sieving, transfer of the sample to the sample vessel, fixation, staining, and labelling, followed by a description of laboratory procedures such as sorting, taxonomic identification, and biomass determinations. A list of items for in-house quality assurance is included together with diagrams of suitable sieving devices and details for a warp-rigged Van Veen grab.

© 1999 International Council for the Exploration of the Sea

Key words: macrozoobenthos, sampling strategy, infauna, epifauna, sampling methods, rejection criteria, treatment of samples, quality assurance, in-house QA manual

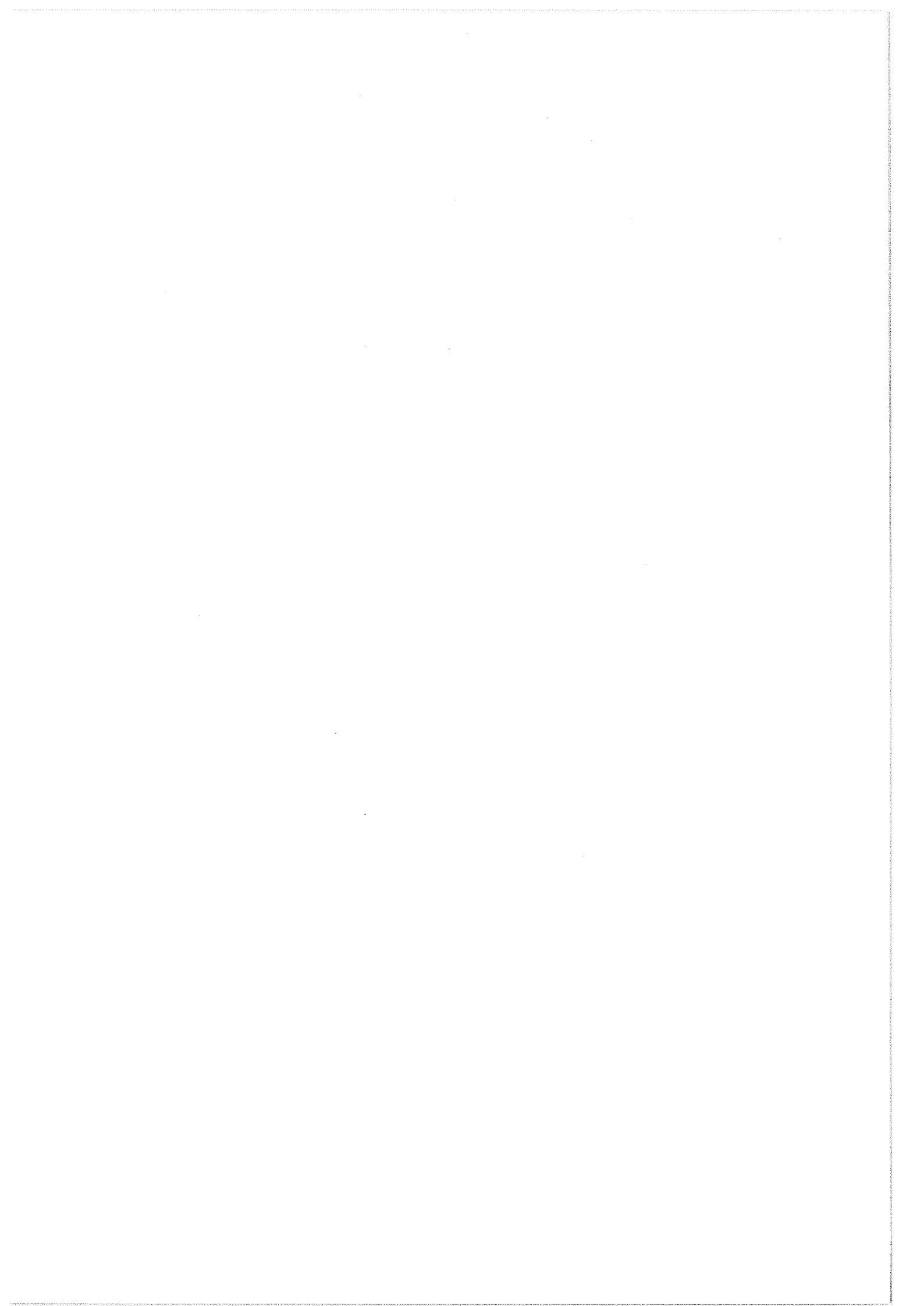

1 INTRODUCTION

The aim of these recommendations¹ is to standardize the methods used by different scientists for long-term benthos surveys, in order to increase the comparability of results for different areas and to enable, *inter alia*, detection of large-scale changes in the system that would not otherwise be detected by scientists or groups working in isolation.

In these recommendations, soft bottoms are defined as those with sediments ranging from mud to, and including, sand. For descriptive surveys, macrofauna is defined as animals retained on a 1 mm sieve (mesh size 1 mm × 1 mm). However, if a finer sieve is used for some other purpose, the 1 mm sieve fraction should always be studied and reported separately to allow comparisons. For a more comprehensive treatment of sampling design, procedures, and alternatives, the reader is referred to, e.g., Kajak (1963), Cochran (1977), Elliott (1977), Green (1979), Downing and Rigler (1984), Holme and McIntyre (1984), and Baker and Wolff (1987).

The development of quality assurance procedures for benthic measurements gave rise to a revision of these guidelines under new criteria developed at a series of ICES/HELCOM Workshops on Quality Assurance of Benthic Measurements in the Baltic Sea (ICES, 1994, 1996). The results of these workshops, intercalibrations, and ring tests have been incorporated in this set of recommendations in order to increase the quality, reliability, and thus comparability of benthos data at a time when an increasing number of people and institutions are engaged in sorting and analysing benthos samples before their final evaluation and the storage of information in public data banks.

2 SAMPLING STRATEGY

The design of the sampling programme largely depends on the detailed aims of the study. The temporal and spatial scales are also of importance for the sampling strategy, as are the local abiotic factors. An awareness of resource limitations (time, money, laboratory facilities) is of the greatest importance (Saila *et al.*, 1976; Bros and Cowell, 1987). The various options in designing a sampling programme can only be mentioned briefly, and the reader is referred to, e.g., Cochran (1977), Elliott (1977), Green (1979), Frontier (1983), Rees *et al.* (1991), Gray *et al.* (1991), and van der Meer (1997), to work out appropriate approaches. It must be stressed that the sampling strategy has a strong influence on the options for later statistical analyses. Thus, the sampling strategy can only be designed after the initial working hypothesis has been formulated, along with the intended statistical tests. Some basic sampling procedures used in benthos investigations are the following:

- time-series sampling (equidistant, at biologically relevant time intervals);
- stratified sampling (according to strata, depth, sediment, etc.);
- randomized sampling;
- single-spot (station) sampling;
- area sampling (grid sampling);

¹ This is a revision of recommendations originally developed by the Baltic Marine Biologists (BMB) (Dybern *et al.*, 1976). Several revisions have been made by members of BMB Working Group 11 ('Secondary Production') and the ICES Benthos Ecology Working Group, with the aim of harmonizing approaches, as far as possible, for the Baltic and North sea environments. This aim was also followed during the last campaign of the ICES/HELCOM Workshop on Quality Assurance of Benthic Measurements in the Baltic Sea, resulting in an extension of applicability to the whole ICES region and even beyond. Dr T.H. Pearson (SEAS Ltd.) and Dr H. Rees (CEFAS) were engaged in all stages of the discussions and provided valuable information and amendments to the manuscript.

- transect sampling (usually along a biological/physical or chemical (contaminant or nutrient) gradient).

Related problems include:

- number of samples;
- sample size;
- precision of results.

2.1 Sampling

There is no single standard sampling gear for benthos investigations. The choice of a suitable sampler is—and always will be—a compromise between specific sampling characteristics in different sediment regimes in the area to be sampled, good handling characteristics at sea in bad weather conditions, suitability for various ships, financial limitations, tradition, and scientific questions. The time required for processing the samples and the level of sampling precision required will also influence the choice of sampling gear (Jensen, 1981; Riddle, 1984; Kingston, 1988).

2.2 Infauna

The choice of an appropriate sampler depends on the average living depth of the infauna in question, which can range from the upper millimetre down to almost one metre (and more). It also clearly depends on the ability of the chosen sampler to penetrate the sediment effectively. One should always be aware of a possible discrepancy between these factors, namely, the penetration depth of the sampler and the living depth, when analysing the results.

2.2.1 Box corer sampling

The box corer is generally recommended for sampling the North Sea benthos because of its generally superior characteristics, especially in sandy sediments. Its advantages are good penetration capability, and relative lack of seabed disturbance and distortion of the sample; the disadvantages are chiefly the need for relatively calm weather and for large vessels to use this heavy and expensive gear. There is no statistical difference between the fauna of silty sediments sampled by the Van Veen grab and by the box corer, as revealed by the Texel Intercalibration Workshop (Heip *et al.*, 1985).

A variety of box corer designs have been successfully employed in benthos research. Most of them are based on the Reineck 'Kastengreifer' design (Reineck, 1963) as, for example, the 'spade corer' by Hessler and Jumars (1974), which has been increasingly widely used in European waters because of its reliability and the large sample volume (0.25 m²). The special advantage is the removable spade from the lever arm, which reduces handling time on board and keeps the sample relatively undisturbed during further processing. This type is also used as a 0.1 m² version with good penetration capabilities, as revealed by closed circuit TV observations. Box corers with round 'boxes' have also been successfully employed by different laboratories; these include the NIOZ type of a modified Reineck with a flat spade and the 'HAPS' design used by Danish research institutes (Kannevorf and Nicolaisen, 1973).

Despite the lack of information on comparative efficiencies of different box samplers, the following features have proved to be useful and are suggested:

- 1) A sufficient number of easily removable weights must be provided. (In silty sediments, the box must not penetrate beyond its own height.)
- 2) Light-operating, flexible flaps, preferably on top of the box, should be provided so as to reduce the bow-wave effect.
- 3) To minimize handling time once the sampler is on board, the spade should be removable from the lever arm. With some types of box samplers, a closing plate has to be fitted between the spade and the box. This operation, which may be difficult, becomes unnecessary when the box containing the sample can be removed together with the spade.

Some precautions that must be taken when using box samplers are similar to those required when using grabs; the latter are listed in the next section.

2.2.2 Grab sampling

When a box corer cannot be employed for various reasons, the already widely used Van Veen grab (Van Veen, 1933, with the modifications described by Dybern *et al.*, 1976; see also Ankar, 1977; Riddle, 1984; and Kingston, 1988) is recommended as one standard sampling gear for benthic macrofauna research, because of its comparative reliability and simplicity of handling at sea. Equally, the Day and Smith-McIntyre grabs are also widely used for similar reasons (see Holme and McIntyre, 1984, for descriptions). However, as yet there is no unequivocal evidence that any one grab performs consistently better than its counterparts, in all conditions. Therefore, in order not to decrease the value of existing time series, all such standard designs may continue to be used, but intercalibrations should be conducted when comparisons between studies are to be made. If the sampling gear in a long-term programme is to be changed, parallel sampling with both gears over at least one year is recommended.

Accepting the above qualifications, some important features of a grab sampler can be listed as follows (chiefly by reference to a Van Veen design, for convenience):

The standard grab should have a sampling area of 0.10 m² and should weigh 35–40 kg (for mud/muddy sands) or 70–100 kg for sandy sediments, when empty; it should have the following technical features:

- 1) In order to reduce the shock wave caused by the grab, the windows on the upper side should cover as large an area as possible (minimum 60 % of the upper surface of the grab). The windows should be covered with metal gauze of 0.5 mm × 0.5 mm mesh size. The mesh size should be smaller when the sample is to be washed over a finer sieve. The windows must be easy to open for inspection and sub-sampling prior to emptying the sample into a container or onto a washing table. Nevertheless, when planning sediment analysis, one should be aware of a possible outwash of fine material during retrieval, in which case sealed flaps will be necessary.
- 2) Means should be provided for attaching an extra 20 kg of lead weights. This is perhaps best done by fastening four equal pieces of lead on the upper edges of the jaws, or inside the grab. One may also, as a complement to the standard weight grab, use a grab made of thicker sheet metal, weighing approximately 20 kg more, when needed.
- 3) Warp rigging of the long-armed grab gives significantly better results on hard and sandy bottoms (see Figure 1) (Kingston, 1988).

- 4) Special attention must be paid to the design of the grab to prevent elevation during closure. The shape of the buckets must be a quarter of a circle, but *length a* must be slightly longer than *length b* (see Figure 2) to provide optimal initial penetration.
- 5) There may be cases where the use of other gear with a smaller sampling area (modified Olausen grab, Ponar grab, Ekman grab) may be advisable (e.g., when the fauna is very dense and uniform); the comparability with other gears in use must nevertheless be proven by intercalibrations.

Figure 1. Warp rigging of the Van Veen grab, which increases digging efficiency.

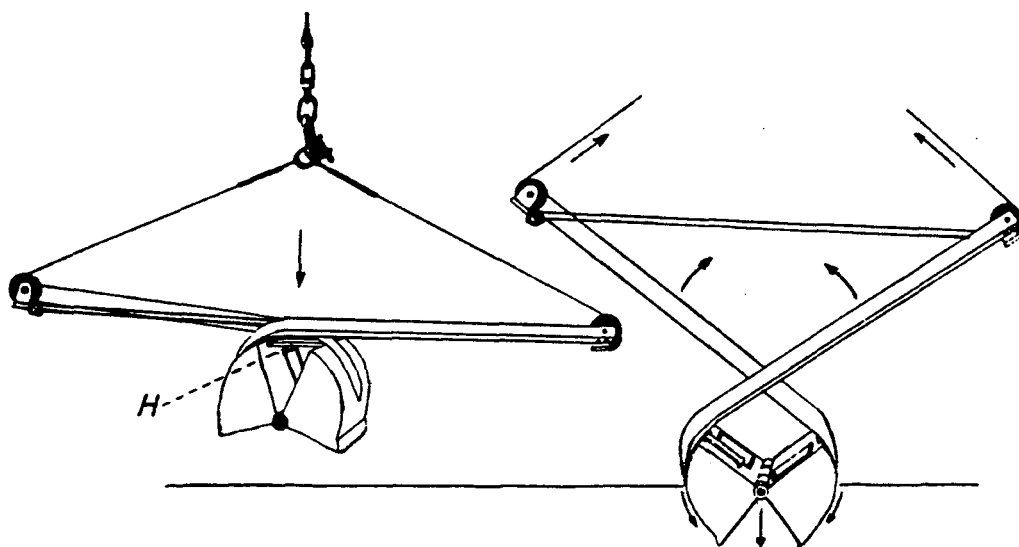

The following precautions should be observed when using a grab (or a box sampler):

- 1) The winching process is regarded as very critical with regard to the maintenance of sample quality. Therefore, winch operation should be standardized, including a complete stop and slow lowering ($< 0.5 \text{ m sec}^{-1}$) for the last few metres. Gentle lowering and heaving of the sampler will (a) reduce the shock wave with its risk of losing surface material, and (b) reduce the risk of loss of sediment by the raising of the sampler before closure is completed.
- 2) The wire must be kept as vertical as possible to guarantee that the sampler is set down and lifted up vertically.
- 3) In densely compacted sediments (e.g., fine sand), additional weights will be needed for the Van Veen grab to ensure adequate penetration. In general, this grab is unsuitable for sediments coarser than medium sand.
- 4) The exact sampling area, the volume, and the digging depth of each particular sampler should be carefully checked and the square-metre values calculated accordingly.
- 5) Special care is needed once the sampler is on board the ship to keep the sample from spilling; the sampler should be rinsed thoroughly to avoid loss of sample.
- 6) The volume of each sample must be measured. This can be done by grading the container or using a ruler.

Figure 2. Cross-section of a bucket that will fit into the hole it digs and permit an 8 cm initial penetration (Riddle, 1984).

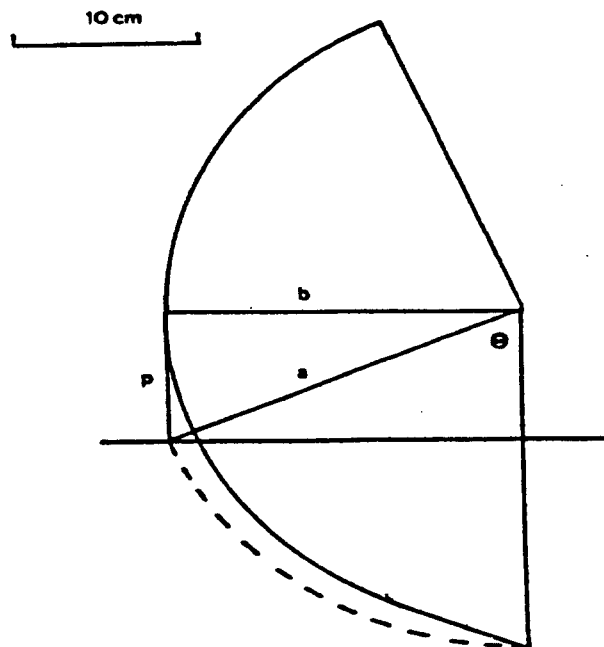

Criteria for rejection of samples

Samples should be rejected and sampling repeated (when possible) if:

- less than 5 litres of sample volume is obtained by a 0.1 m² grab in soft sediments or less than 2.5 litres in hard-packed sand (for HAPS, less than 15 cm penetration);
- incomplete closure is noted;
- obvious uneven bite is noted;
- spillage during transferring of samples is observed;
- samples clearly deviate from the other samples (i.e., there is an observed change from clean sand samples to *Mytilus* bank samples). The samples should nevertheless be kept, in order to record faunal patchiness, but another sample should be taken to replace it in calculating the mean for the station.

2.2.3 Diver-operated samplers

SCUBA diving is a very useful method for sampling shallow soft bottoms, and will give more reliable data than the recommended grab method.

SCUBA sampling can be done with tubes of, e.g., acrylic glass (Jensen, 1983), but diver-operated box corers (Rumohr and Arntz, 1982) or suction samplers, such as that described by Hiscock and Hoare (1973), can also be used on mud to sand bottoms. Further references on sampling by SCUBA diving can be found in Holme and McIntyre (1984).

2.3 Epifauna

The epifauna of marine sediments is a component of the benthic community that is generally not effectively sampled by grabs and corers. Many attempts have been made to sample parts of this fauna with various methods that differ markedly in efficiency, as described below.

2.3.1 Dredges and trawls

Dredge, epibenthic net, and beam-trawl hauls may be valuable as a complement to grab or box corer samples, since large sedentary, but comparatively rare, species especially of the epifauna are seldom caught in sufficient numbers with grabs and corers. Descriptions of suitable devices can be found in Holme and McIntyre (1984). Standardized dredging should always be used when grab samples devoid of macrofauna are encountered.

Considerable caution is, however, required in treating benthos data from trawls and dredges in a quantitative manner owing to uncertainties about sampling efficiency. For example, marked differences in capture efficiency often result from changes in fishing practices. It is, therefore, recommended that every effort be made to follow consistent sampling procedures. Dredging can be useful for semi-quantitative sampling, for example, employing a five-point scale of abundance (none–single–few–many–multitude).

To ensure a degree of comparability between studies, the following protocol is recommended. It should be noted, however, that although the following suggested practice has proved successful in the North Sea and other areas, modifications may be necessary if the gear becomes clogged or if insufficient material is caught.

A beam trawl with a minimum beam breadth of 2 m is recommended as a standard gear. It should be equipped with at least one tickler chain, and the minimum mesh size in the codend should not exceed 1 cm × 1 cm. For a 2 m trawl, a distance of 1 nautical mile is suggested; shorter distances may be appropriate for wider gear and other areas. It is important that the trawling distance be kept constant in a survey and be measured from the point at which the gear reaches the bottom to the beginning of recovery.

It is inappropriate to recommend a single towing speed owing to differences in vessel size, etc. (although for small vessels a speed of 2 miles per hour over the ground may be suitable). However, the importance of maintaining a constant speed and direction with reference to any current, both within and between tows, should be stressed. The processing of the samples should be done as follows:

- 1) Sample volume should be estimated, the sample documented photographically, and then sieved. As a minimum requirement, the material obtained should be sieved with a mesh size equal to the minimum one for the net.
- 2) Additional finer fractions may be collected and, in particular, the < 1 mm fraction may usefully be retained as a reference for core or grab samples. (A 1 litre sample is normally sufficient for this purpose.)
- 3) For general epifauna surveys, only the material retained by the sieve with the minimum net mesh size should be referred to, as this is the only size class caught consistently. In larger samples, the use of a sieve with very large meshes (e.g., 2 cm) in addition to the sieve with the critical mesh size is recommended. Usually the very large megabenthos retained by such a sieve do not pose problems of identification, and can easily be processed on board ship. If the survey has to be run with insufficient scientific manpower and completed in a very short time, sample processing in the laboratory may be required. In this case, samples

with a volume of less than 20 litres should be fixed and carried back as a whole, while larger catches should be sub-sampled and about 20 litres should be fixed. It may be noted, however, that while this procedure may be acceptable for extrapolating densities of most species, it cannot account for the totality of species occurrences in a sample. A complete census will only be possible by sorting the entire sample contents. In the laboratory, the fixed (sub-)samples should be sieved and evaluated using the same approach as described above.

In addition to the above procedures, the following information should be recorded:

- weather conditions;
- wind speed and direction;
- sea state;
- start-position of the tow;
- end-position of the tow;
- time of day;
- depth range;
- volume of sample;
- presence of artefacts.

It should be noted that more sophisticated gear, such as epibenthic sledges, may be required for sampling hyperbenthic or benthopelagic species. Such gear is particularly valuable for studies of species (especially crustaceans) which constitute an important component of the diet of fish. Epibenthic and hyperbenthic sledges (i.e., the Brattegard dredge; see Brattegard and Fossa, 1991) are useful for the small mobile crustaceans and boundary fauna. If automatic closing mechanisms and dredge distance recorders are added, then these instruments can be quantitative (cf. Gage deep sea epibenthic sledge). Special attention is drawn to a new design of a dredge for the quantitative collection of the large and rare epifauna and infauna (Triple-D dredge; see Bergman and van Santbrink, 1994).

2.3.2 Underwater photography and television

Under certain circumstances, photographic and video records from drop frames, sledges, and remotely operated vehicles (ROVs) may provide reliable estimates of densities for conspicuous epifaunal species. A major advantage of such methods over dredges and trawls is that they reduce the uncertainty associated with sampling efficiency, and data are more amenable to statistical analysis. In addition, such methods allow large areas to be surveyed and provide a means for assessing topographical and biological patterns, which may not be revealed by sampling at discrete stations.

However, there are a number of limitations to visual (imaging) techniques:

- 1) The backscatter of light under turbid conditions results in poor images.
- 2) There is selectivity: highly motile and cryptic species are not likely to be represented in visual records. (Such species may represent a substantial fraction of the epifauna.)
- 3) Equipment costs and maintenance requirements may be prohibitive.

In view of the limitations of both TV/photographic and trawl/dredge sampling, a combination of both approaches is to be recommended, where possible. A review of the use of imaging in benthos monitoring can be found in Rumohr (1995).

3 TREATMENT OF SAMPLES

3.1 Separation of Fauna from the Sediment

The transfer of the sample to the sieve, the sieving procedure, and the transfer of the animals to the fixation jar are the steps during sample treatment most likely to introduce sources of error. To reduce the magnitude of these errors, the number of steps in the sampling and sieving procedures should be kept as small as possible and attention should be paid to the following procedures.

3.1.1 Sieves

For descriptive surveys, sieves used for extraction of the macrofauna from sediments should have a mesh size of 1.0 mm. The use of an additional finer sieve of mesh size 0.5 mm, or even finer, is recommended for special purposes (see, for example, Section 3.8, below). The sieve mesh should be checked from time to time for damage and wear. If a finer sieve is also used, the sieve fractions should be treated separately, and the results should be given for the single and the summed fractions. If re-sieving of samples is carried out, a mesh size finer than that of the initial sieve should always be used. Small sieves may be cleaned with an ultrasonic bath. The use of brushes should be avoided to prevent possible alterations of the mesh size. Distortion of woven mesh sieves occurs with increasing frequency of use. This can introduce considerable errors in the collection of small organisms. Moreover, the use of a square mesh introduces additional inaccuracies in collecting organisms in the size range of approximately the mesh size since the mesh diagonal width is greater than the nominal mesh width. The use of larger sieves is encouraged because the risk of clogging is reduced, for example, sandy samples may rapidly fill or even overflow smaller sieves. Larger sieves also reduce the risk of spilling when transferring samples from containers/buckets to the sieve. This risk can also be kept low by using integrated sieve tables, as shown in Figure 3.

It may be noted that a growing number of institutes are changing to round mesh sieves, owing partly to a perceived improvement in the condition of the animals retained and partly to the theoretical improvement in mesh selectivity. Further work is required to establish a basis for using either type of sieve. Errors associated with the use of different sieves are likely to be small in relation to other sources of sampling error.

There are new designs of sieving tables with hand-controlled water sprinklers, which help to reduce the physical stress on the people involved while at the same time retaining the quality of the sampled specimens (Figure 3). Also, tilting devices for the full sample container, providing the option to fix the container at a certain angle over the sieve, are of use to reduce spilling and to avoid destructive tools. One example of a smaller sieve holder is shown in Figure 4. With this stand, the sieve residue can be transferred to the sample container with only the help of a sprinkler bottle, thereby avoiding the need for spoons or other scraping tools.

3.1.2 Sieving procedure

Sieving should be conducted according to the following procedure:

- 1) Each grab and box core sample should be sieved, stored, and documented separately.

- 2) The grab or box core should be emptied into a container, and then the sample should be transferred portion by portion onto the sieves, as a sediment-water suspension. The use of sprinklers or hand-operated douches to suspend the sample is recommended. Very stiff clay can be gently fragmented by hand in the water of the container. The sieve must be cleaned after each portion has been sieved to avoid clogging and to ensure an equal mesh size throughout the entire sieving procedure.
- 3) In order to avoid damaging fragile animals, the most gentle way to sieve a sample is to gently agitate the sieve surface under the water surface of a water-filled container until all sediment that can pass the sieve is washed through. On no account should water jets (i.e., deck hose) be used against the sieve surface.
- 4) Fragile animals, such as some polychaetes, should be picked out by hand during the sieving, to minimize damage. Also, stones and large shells should be picked out, to avoid a grinding effect on the organisms and the sieve.
- 5) All material retained on the sieve should be carefully flushed off the sieve, with water from below, into an appropriate recipient and fixed. The use of spoons or other scraping tools should be avoided (see Section 3.1.1).
- 6) When the 0.5 mm sieve is used, the 0.5 mm and the 1 mm fractions must be kept separate throughout all further processing.

Figure 3. Cross-section of a sieving table where the sample is first emptied onto a coarse sieve (~5 mm) from where it is washed with a hand sprinkler douche onto the final 1 mm (0.5 mm) sieve (design provided by G. Fallesen, Aarhus, Denmark).

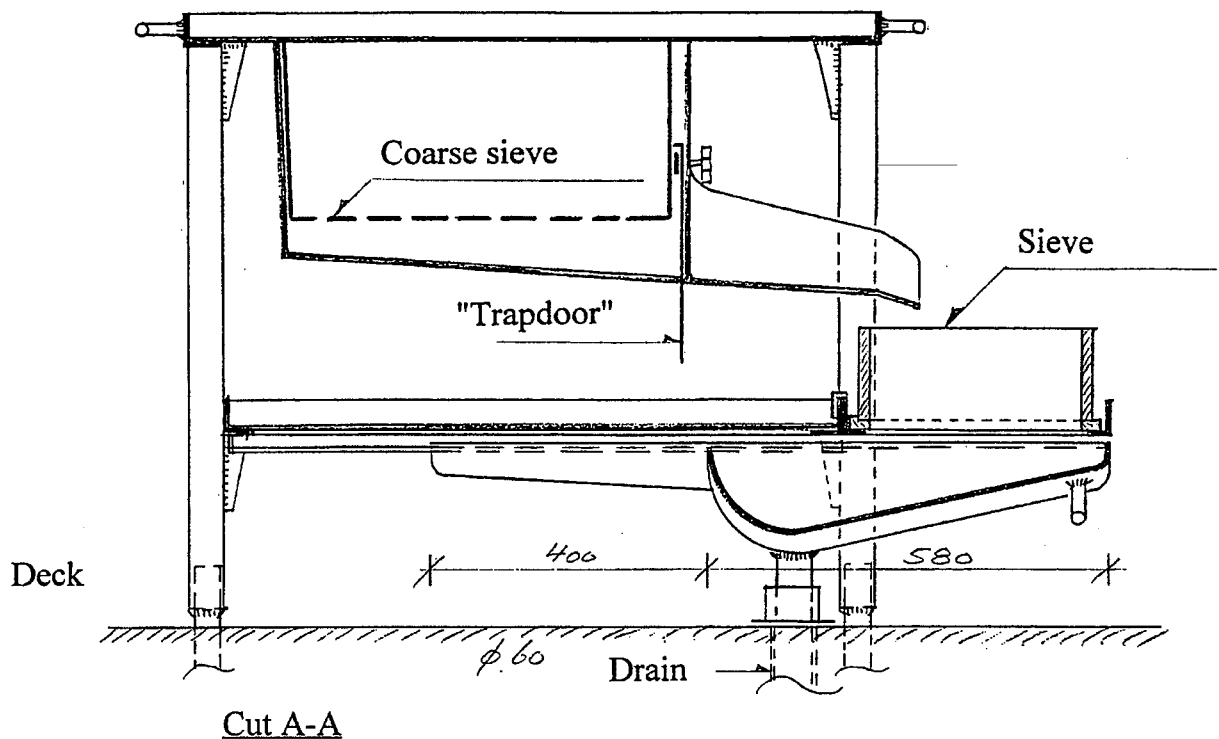
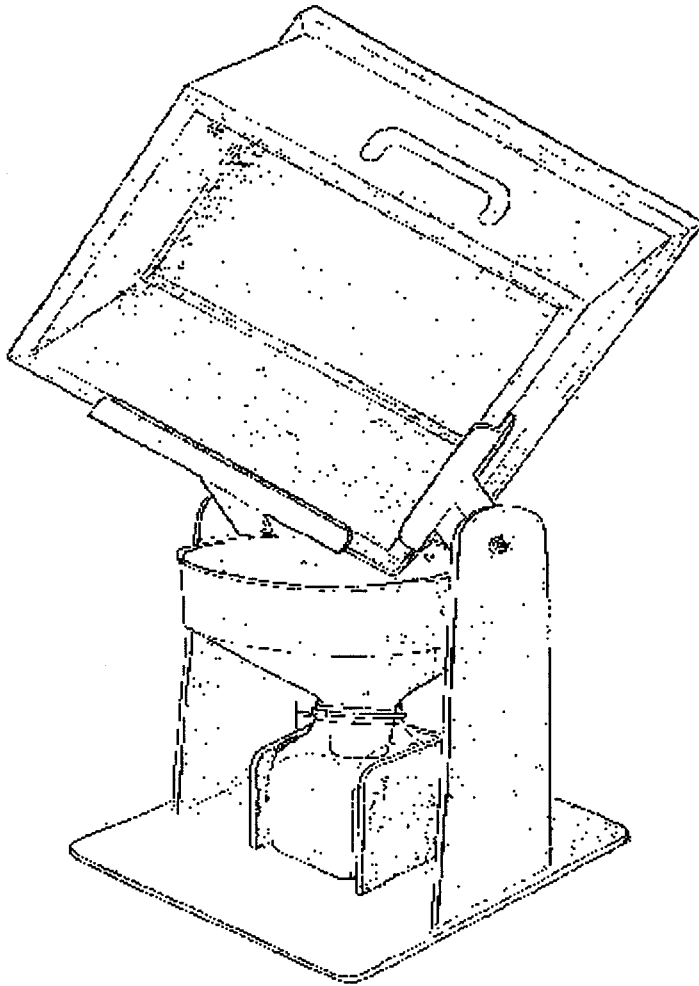

Figure 4. Sieve holder to provide a careful transfer of the sieve residue to the sample vessel (no tools needed—only a funnel and a wash bottle).



Redford 1974

3.2 Fixation

It should be noted that fixation and conservation (preservation) are two different steps in the treatment of a sample. The former procedure is employed to coagulate and harden the tissue of the organisms, while the latter prevents them from rotting and decaying. Improperly fixed specimens may create problems during further treatment, i.e., through fragmentation of specimens or loss of appendages. Some zoological museums will only accept properly (formalin-) fixed specimens for further analysis and curation.

All the material retained on the sieves should be fixed in a buffered 4 % formaldehyde solution (1 part 40 % formaldehyde solution and 9 parts filtered sea water). For buffering, 100 g of hexamethylene tetramine (= Hexamine, = Urotropine) can be used per 1 litre of concentrated formaldehyde (36–40 %). Sodium tetraborate (= Borax) in excess may also be used. Sponges are best preserved by putting them directly into absolute ethyl alcohol so as to prevent fragmentation.

It should be noted that formaldehyde is regarded as a toxic compound, and probably also carcinogenic, and should, therefore, be handled with great care. Appropriate means of laboratory air suction or ventilation should be provided for all procedures. For animal sorting, the samples should first be thoroughly washed with tap water and left to soak over night so that sorters are not exposed to formalin vapour. Other fixation fluids that do not release formalin gas have been tested, such as formaldehyde depot chemicals (Dowicil 75 and Kohrsolin) used in clinics for sterilization purposes. The effects of these fluids on dry weight and ash-free dry weight are marked and the effects on long-term storage are unclear, so that no unequivocal recommendation can be given (Brey, 1986).

In special cases, such as the study of the length distribution of polychaetes, the use of narcotizing agents prior to fixation may be advisable. For detailed information, see Steedman (1976) and Lincoln and Sheals (1979).

3.2.1 Staining

To facilitate sorting and to increase sorting accuracy, especially for small animals, staining the sample with, e.g., Rose Bengal, is recommended. However, in some cases, staining may cause problems with species identification and the time gained during sorting will therefore be more than offset. Zoological museums will not accept stained material for taxonomic purposes. The following procedure has been shown to give good results:

- 1) Wash the sample free from the preservation fluid by using a sieve with a mesh size smaller than $0.5 \text{ mm} \times 0.5 \text{ mm}$.
- 2) Allow the sieve to stand in Rose Bengal stain (1 g dm^{-3} of tap water plus 5 g of phenol for adjustment to pH 4–5) for 20 minutes with the sample well covered.
- 3) Wash the sample until the tap water is no longer coloured.

As an alternative, Rose Bengal (4 g dm^{-3} of 40 % formaldehyde) may be added to the fixation fluid. Overstained specimens may be destained in alkaline (pH 9) fluids (Thiel, 1966).

3.3 Sieving of Fixed Material

Samples may be sieved 'alive', as is the usual practice, or preserved. If they are preserved, it must be realized that the sorting characteristics are different from those for live fauna and result in apparently higher abundance and biomass figures. Intercalibrations of both procedures should be performed. In publications, it should always be stated whether the sieved material was fresh (alive) or fixed.

3.4 Sorting

Sorting must be done using some magnification aid (magnification lamp, stereomicroscope). Any finer fraction ($< 1 \text{ mm}$) should always be sorted under a stereomicroscope.

When taxa occur in great numbers (e.g., *Polydora*, phoronids, capitellids), it may be advisable to split the samples to reduce the counting time. Different types of sample splitters can be used. Rare species should be counted from whole samples. The accuracy of the sample-splitting device should be adequately assessed. To reduce sorting time, a sorting aid (such as the one described by Pauly (1973) or a 'fluidized sand bath' (after P. Barnett, see Holme and McIntyre, 1984)) may be used, provided that its efficiency has been satisfactorily checked for the particular bottom material studied. The Ludox method (see Higgins and Thiel, 1988) has

successfully been applied to meiobenthos work and may also prove useful for the extraction of soft-bodied macrofauna.

In coarse sand, the following procedure may be recommended: the sediment is fixed and placed on a PVC trough 5 m long, 20 cm wide, and 20 cm high (an ordinary gutter of the same length may also be used). Water is poured over the sediment from one closed side and the extracted fauna caught on a sieve on the other (open) side (Vanosmael *et al.*, 1982).

If samples are sorted alive, care should be taken to avoid predation within the sample.

3.5 Biomass Determination

The following measures of biomass determination can be used: wet weight, dry weight, and/or ash-free dry weight, either from fresh or fixed material. Furthermore, energy content (J) and/or matter equivalents (C, N, P) may be determined, using fresh material only. Fresh wet weight is to be preferred to formalin wet weight, but if the latter has to be used, weighing should not be done until at least three months after fixation (Brey, 1986).

The wet weight is obtained by weighing after the external fluid has been removed on filter paper. The animals are left on the filter paper until no more distinct wet traces can be seen. Animals with shells are generally weighed with their shells; the water should be drained off bivalves before weighing. When shell-free weights are given, the shell weight should be included in the data list. Echinoids should be punctured to drain off the water before blotting on filter paper. As soon as the non-tissue water has been removed, the organisms are weighed with the accuracy required (for adult macrofauna: 0.1 mg). In case tube-building animals have to be weighed together with their tubes, appropriate correction factors should be established.

The dry weight should be estimated after drying the fresh material at 60 °C, or by freeze drying, until constant weight is reached (at least 12–24 hours, depending on the thickness of the material; large bivalves may need up to 96 hours). Dry weights obtained by lyophilization (freeze drying) are slightly higher than those obtained by oven drying. For *Mytilus*, lyophilized tissues weighed 10.9 % more than oven-dried tissues (Gaffney and Diehl, 1986).

The use of ash-free dry weight is recommended in routine programmes, because it is the most accurate measure of biomass (Rumohr *et al.*, 1987; Duineveld and Witte, 1987). However, it destroys specimens, and the consequences of this should be carefully considered. Ash-free dry weight should be estimated after measuring dry weight. It is determined after incineration at 500 °C in an oven until weight constancy is reached (~6 hours, depending on sample and object size). The temperature of the oven should be checked with a calibrated thermometer because there may be considerable temperature gradients (up to 50 °C) in a muffle furnace. Caution is advised to avoid exceeding a certain temperature (> 550 °C), at which a sudden loss of weight may occur owing to the formation of CaO from the skeletal material of many invertebrates (CaCO₃). This can reduce the weight of the mineral fraction by 44 %. Such decomposition occurs very abruptly and within a small temperature interval (Winberg, 1971). Before weighing, the samples must be kept in a desiccator while cooling down to room temperature after oven drying or removal from the muffle furnace.

To estimate biomass from length or size measurements, conversion factors may also be used (Rumohr *et al.*, 1987; Brey *et al.*, 1988).

3.6 Preservation and Storage

After sorting, weighing, and measuring, the animals (if still existing) should be transferred to a preservation fluid such as 70–80 % alcohol or a saturated solution of propylene phenoxetol (for further information, see Lincoln and Sheals, 1979). If tap water is used, the pH should be adjusted to 7.

3.7 Reference Collection

It is advisable, even with routine samplings, to place some specimens of each taxon ('voucher specimens') under museum curatorship to make later taxonomic checks possible. Laboratory reference collections should be validated by taxonomic experts.

3.8 Determination of Production

For detailed production studies, routine samples may often be insufficient because survey data generally are inadequate for such studies. Therefore, the following additional recommendations are given in order to cover the entire size/age range of the population:

- 1) The use of appropriate finer sieves may be needed, depending on the size of the bottom-living stages of particular species.
- 2) Sampling frequency may have to be increased to cover the seasonal variations in condition and population density over the entire life cycle.
- 3) Size/weight relationships have to be established for the species studied.

The computation of production is described in detail by Crisp (1984) and by Feller and Warwick (1988) for meiofauna. Attention is drawn to new techniques for analysing length frequencies using a computer (Brey, 1986; Brey and Pauly, 1986). For rough production estimates, production:biomass (P/B) ratios may be used (Schwinghamer *et al.*, 1986).

3.9 Integration with Meiofauna Studies

When sampling for both macrofauna and meiofauna at the same station, all sieving fractions from the meiofauna samples (including the 1.0 mm sieve) should be sorted and weighed so that no size classes are lost, and the problem of the overlap between juvenile macrofauna/meiofauna (e.g., Oligochaeta, Ostracoda, Chironomidae, Nemertini, Nematoda) can be avoided. In general, grab samples are unsuitable for meiofauna studies, since the upper sediment layer may be flushed away during sampling. Meiofauna samples should preferably be taken with diver-operated corers, tube corers such as the Craib corer, or as sub-samples from box core samples. Special extraction procedures are described by Holme and McIntyre (1984) and Higgins and Thiel (1988). Further information on the use of meiofauna in marine pollution monitoring can be obtained from Platt and Warwick (1988) and Somerfield and Warwick (1996).

4 PUBLICATION OF ABUNDANCE AND BIOMASS RESULTS

In investigations of soft bottom macrofauna, the published results should include data for each individual sample and/or average values with standard errors or standard deviations (always stating which is reported) and number of samples, for both abundance and biomass for each taxon and the total fauna. When two or more sieve fractions are collected, these statistics should be given at least for the 1 mm fraction and the sum of the fractions. If sample splitting was done, this should be stated when reporting the data, and the type of the splitter should be given.

Whenever some taxon found on the sieves is excluded from the published results, this should be explicitly stated and the reasons given (e.g., *Piscicola geometra* not included because it is a parasite). For general information on how data should be reported to several intergovernmental organizations, see the ICES Biological Data Reporting Formats, that are available from the ICES website on <http://www.ices.dk/env/repfor/index.htm>.

For coding purposes, the valid taxonomic name and/or the NODC code (Version 7.1) may be used. The widely used RUBIN code (Zetterberg, 1982) is no longer maintained and will be outdated sooner or later. There may be follow-up systems on the market (ITIS), the applicability of which cannot be judged yet. They are no longer hierarchical codes, but rather serial numbers. With the advent of PCs and enhanced computer power, it is relatively easy to translate from one code to another. See also <http://www.ices.dk/env/repfor/index.htm>.

It is recommended that data and results be published in journals widely accessible to the scientific community.

5 STATION DATA

Data recorded must include the following items: whether the ship was anchored or not, time of day, weather conditions during sampling, and a description of the sediment (Briggs, 1977). Near-bottom temperature, salinity, and oxygen measurements are desirable. For macrofauna work, the type and specifications of the sampler are to be stated. If more than one sample is taken, the depth range of samples should be expressed. The items to be reported can be found on the ICES web page <http://www.ices.dk/env/repfor/index.htm>.

The sediment description should encompass the following:

- 1) simple measure of grain size distribution (ϕ -scale: silt/clay fraction < 63 μm , 125 μm , 250 μm , 500 μm , 1000 μm , 2000 μm);
- 2) median grain size for the upper 5 cm;
- 3) weight loss on ignition (500–520 °C);
- 4) surface colour and colour change with depth as a possible indicator of redox state;
- 5) smell (H_2S);
- 6) description of sediment types, including important notes, e.g., the occurrence of concretions, loose algae, etc.

When describing the sediment, the recommendations presented on the ICES web page should be followed. The use of stainless steel buckets or box corers is advocated in cases where the sediments are to be sub-sampled for trace metal and organic contaminants determinations.

It is recommended that measurements of redox potential and shear strength be made in samples collected by a box corer rather than a grab because the latter has a great chance of distorting the sample.

Precise position fixing during sampling is essential. The position and the depth should be controlled and documented by track plotting during station work.

6 IN-HOUSE QUALITY ASSURANCE

It is essential that at every phase of a monitoring or assessment survey, built-in controls are enforced to ensure the quality of data acquisition, collection, handling and analysis, and of subsequent reporting. In-house Quality Assurance manuals should be developed in accordance with appropriate national and international standards and followed rigorously. Some of the items listed below have already been covered by this publication in more detail. Such manuals should at least include the following topics:

- 1) Formal listing of survey personnel.
- 2) Procedures for the handling and use of chemicals (i.e., formaldehyde and other reagents) in marine environmental surveys.
- 3) Procedures for handling survey equipment.
- 4) Procedures for station selection and location, as well as navigational accuracy and documentation.
- 5) Procedures for the collection of biological material.
- 6) Procedures for the storage of biological material.
- 7) Procedures for sorting biological material.*
- 8) Procedures for the distribution of sorted biological material for taxonomic analysis. Signed protocols should be obligatory for all steps in analysis.
- 9) Procedures for identifying biological material.*
Taxonomic accreditation of the persons at the laboratories should be aimed at. Training should be offered by institutions possessing the appropriate level of expertise in the form of regular taxonomic workshops and ring tests. Participation in these workshops on a regional basis should be obligatory for all laboratories delivering data to public data banks. Taxonomic cross-checks between laboratories should be encouraged.
- 10) Procedures for the recording of biological and environmental data.**
- 11) Procedures for the analysis of biological and environmental data.
- 12) Procedures for survey report writing and documentation.
- 13) Details of the professional qualifications of survey and laboratory personnel.

* These procedures should include the random check sorting and identification by experienced controlling personnel.

** These procedures should include obligatory proof-reading before entering into a computer, and before usage.

7 REFERENCES

- Ankar, S. 1977. Digging profile and penetration of the Van Veen grab in different sediment types. *Åskö Laboratory*, 16: 3–22.
- Baker, J.M., and Wolff, W.J. (Eds.) 1987. *Biological surveys of estuaries and coasts*. Cambridge University Press, Cambridge. 449 pp.
- Bergman, M., and van Santbrink, J.W. 1994. A new benthos dredge ('Triple-D') for quantitative sampling infauna species of low abundance. *In Environmental impact of bottom gears on benthic fauna in relation to natural resources management and protection of the North Sea*, pp. 251–257. Ed. by S.J. de Groot and H.J. Lindeboom. NIOZ Rapport 1994-11.
- Brattegård, T., and Fosså, J.H. 1991. Replicability of an epibenthic sampler. *Journal of the Marine Biological Association of the United Kingdom*, 71: 153–166.
- Brey, T. 1986. Estimation of annual P/B-ratio and production of marine benthic invertebrates from length-frequency data. *Ophelia Supplement*, 4: 45–54.
- Brey, T., and Pauly, D. 1986. Electronic length frequency analysis. A revised and expanded user's guide to ELEFAN 0, 1 and 2. *Berichte aus dem Institut für Meereskunde Kiel*, No. 149. 76 pp.
- Brey, T., Rumohr, H., and Ankar, S. 1988. The energy content of macrobenthic invertebrates. General conversion factors from weight to energy. *Journal of Experimental Marine Biology and Ecology*, 117: 271–278.
- Briggs, D. 1977. *Sediments*. Butterworths, London. 190 pp.
- Bros, W.E., and Cowell, B.C. 1987. A technique for optimising sample size. *Journal of Experimental Marine Biology and Ecology*, 114: 63–71.
- Cochran, W.G. 1977. *Sampling techniques*. Third edition. John Wiley and Sons, New York. 428 pp.
- Crisp, D.J. 1984. Energy flow measurements. *In Methods for the study of marine benthos*, pp. 284–372. Ed. by N.A. Holme and A.D. McIntyre. Blackwell Scientific, Oxford. 387 pp.
- Downing, J.A., and Rigler, F.H. 1984. *A manual on methods for the assessment of secondary productivity in fresh waters*. IBP Handbook 17. Second edition. Blackwell Scientific, Oxford. 501 pp.
- Duineveld, G.C.A., and Witte, H.J. 1987. Report on an intercalibration exercise on methods for determining ash-free dry weight of macrozoobenthos. ICES CM 1987/L:39.
- Dybern, B.I., Ackefors, H., and Elmgren, R. 1976. Recommendations on methods for marine biological studies in the Baltic Sea. *Baltic Marine Biologists*, Publication No. 1. 99 pp.
- Elliott, J.M. 1977. Some methods for the statistical analysis of samples of benthic invertebrates. *Scientific Publications, Freshwater Biological Association*, No. 25. 158 pp.
- Feller, R.J., and Warwick, R.M. 1988. Energetics. *In Introduction to the study of meiofauna*, pp. 181–196. Ed. by R.P. Higgins and H. Thiel. Smithsonian Institution Press, Washington, D.C. and London.

- Frontier, S. 1983. *Stratégies d'échantillonnage en écologie*. Masson, Paris, et les Presses de l'Université Laval, Québec. 494 pp.
- Gaffney, P.M., and Diehl, W.J. 1986. Growth, condition and specific dynamic action in the mussel *Mytilus edulis* recovering from starvation. *Marine Biology*, 93: 401–409.
- Gray, J.S., McIntyre, A.D., and Stirn, J. 1991. *Manual of methods in aquatic environment research*. Part 11. Biological assessment of marine pollution with particular reference to benthos. FAO Fisheries Technical Paper No. 324. FAO, Rome. 49 pp.
- Green, R.H. 1979. *Sampling design and statistical methods for environmental biologists*. John Wiley & Sons, New York. 257 pp.
- Heip, C., Brey, T., Creutzberg, F., Dittmer, J., Dörjes, J., Duineveld, G., Kingston, P., Mair, H., Rachor, E., Rumohr, H., Thielemann, L., and Vanosmael, C. 1985. Report on an intercalibration exercise on sampling for macrobenthos. ICES CM 1985/L:19.
- Hessler, R.R., and Jumars, P.A. 1974. Abyssal community analysis from replicate box cores in the central North Pacific. *Deep Sea Research*, 25: 1029–1047.
- Higgins, R.P., and Thiel, H. 1988. *Introduction to the study of meiofauna*. Smithsonian Institution Press, Washington, D.C. 470 pp.
- Hiscock, K., and Hoare, R. 1973. A portable suction sampler for rock epibiota. *Helgoländer Wissenschaftliche Meeresuntersuchungen*, 25: 35–38.
- Holme, N.A., and McIntyre, A. 1984. *Methods for the study of marine benthos*. IBP Handbook, 16. Second edition. Oxford. 387 pp.
- ICES. 1994. ICES/HELCOM Workshop on Quality Assurance of Benthic Measurements. ICES CM 1994/E:10.
- ICES, 1996. ICES/HELCOM Workshop on Quality Assurance and Intercomparison of Benthos Measurement Methods in the Baltic Sea. ICES CM 1996/E:2.
- Jensen, K. 1981. Comparison of two bottom samplers for benthos monitoring. *Environmental Technology Letters*, 2: 81–84.
- Jensen, P. 1983. Meiofaunal abundance and vertical zonation in a sublittoral soft bottom with a test of the HAPS corer. *Marine Biology*, 74: 319–326.
- Kajak, Z. 1963. Analysis of quantitative benthic methods. *Ekologia Polska, Series A*, 11 (1): 1–56.
- Kanneworf, E., and Nicolaisen, W. 1973. The 'HAPS': a frame supported bottom corer. *Ophelia*, 10: 119–129.
- Kingston, P. 1988. Limitations on off-shore environmental monitoring imposed by sea bed sampler design. *Advances in Underwater Technology, Ocean Science, and Off-shore Engineering*, 16/31: 273–281.
- Lincoln, J.R., and Sheals, J. 1979. *Invertebrate animals (collection and preservation)*. British Museum, Cambridge. 150 pp.

- Pauly, D. 1973. Über ein Gerät zur Vorsortierung von Benthosproben. *Berichte der Deutschen Wissenschaftlichen Kommission für Meeresforschung*, 22 (4): 458–460.
- Platt, H.M., and Warwick, R.M. 1988. Freelifving marine nematodes. Part II. British Chromadorids. *Synopses of the British fauna (New Series) No. 38*. Ed. by D.M. Kermack, R.S. Barnes, K. Brill, and W. Blackhuys. 502 pp.
- Rees, H., Heip, C., Vincx, M., and Parker, M.M. 1991. Benthic communities: Use in monitoring point-source discharges. *ICES Techniques in Marine Environmental Sciences*, No. 16. 70 pp.
- Reineck, H.E. 1963. Der Kastengreifer. *Natur und Museums*, 93: 102–108.
- Riddle, M.J. 1984. Offshore benthic monitoring strategies. Ph.D. thesis. Heriot-Watt University, Edinburgh. 335 pp.
- Rumohr, H. 1995. Monitoring the marine environment with imaging methods. *Scientia Marina*, 59 (Suppl. 1): 129–138.
- Rumohr, H., and Arntz, W.E. 1982. The 'Benthosgarten'—a new approach for the study of soft bottom communities. *Meeresforschung; Report on Marine Research*, 29: 225–238.
- Rumohr, H., Brey, T., and Ankar, S. 1987. A compilation of biometric conversion factors for benthic invertebrates of the Baltic Sea. *Baltic Marine Biologists, Publication No. 9*. 56 pp.
- Saila, S.B., Pikanowski, R.A., and Vaughan, D.S. 1976. Optimum allocation strategies for sampling benthos in the New York Bight. *Estuarine and Coastal Marine Science*, 4: 119–128.
- Schwinghamer, P., Hargrave, B., Peer, D., and Hawkins, C.M. 1986. Partitioning of production and respiration among size groups of organisms in an intertidal benthic community. *Marine Ecology Progress Series*, 31: 131–142.
- Somerfield, P.J., and Warwick, R.M. 1996. Meiofauna in marine pollution monitoring programmes. A laboratory manual. MAFF Directorate of Fisheries Research, Lowestoft. 71 pp.
- Steedman, H.F. 1976. Zooplankton fixation and preservation. UNESCO Press, Paris. 350 pp.
- Thiel, H. 1966. Quantitative Untersuchungen über die Meiofauna des Tiefseebodens. *Veröffentlichungen des Instituts für Meeresforschung, Bremerhaven, Sonderband II*: 131–148.
- Vanosmael, C., Willems, K.A., Claeys, D., Vincx, M., and Heip, C. 1982. Macrobenthos of a sublittoral sandbank in the Southern Bight of the North Sea. *Journal of the Marine Biological Association of the UK*, 62: 521–534.
- Van Veen, J. 1933. Onderzoek naar het zandtransport van rivieren. *De Ingenieur*, 48: 151–159.
- van der Meer, J. 1997. Sampling design of monitoring programmes for marine benthos: a comparison between the use of fixed versus randomly selected stations. *Journal of Sea Research*, 37: 167–179.
- Winberg, G.G. 1971. Methods for the estimation of the production of aquatic animals. Academic Press, London, New York. 175 pp.

Zetterberg, G. 1982. Code list of Baltic invertebrates. National Swedish Environment Protection Board, SNV PM 1557. 105 pp.

ICES Techniques in Marine Environmental Sciences

- No. 1 Cadmium and lead: Determination in organic matrices with electrothermal furnace atomic absorption spectrophotometry
- No. 2 Trace metals in sea water: Sampling and storage methods
- No. 3 Cadmium in marine sediments: Determination by graphite furnace atomic absorption spectroscopy
- No. 4 Lipophilic organic material: An apparatus for extracting solids used for their concentration from sea water
- No. 5 Primary production: Guidelines for measurement by ¹⁴C incorporation
- No. 6 Control procedures: Good laboratory practice and quality assurance
- No. 7 Suspended particulate matter: Collection methods for gravimetric and trace metal analysis
- No. 8 Soft bottom macrofauna: Collection and treatment of samples
- No. 9 Sediments and suspended particulate matter: Total and partial methods of digestion (*videotape available*)
- No. 10 Organic halogens: Determination in marine media of adsorbable, volatile, or extractable compound totals
- No. 11 Biological effects of contaminants: Oyster (*Crassostrea gigas*) embryo bioassay
- No. 12 Hydrocarbons: Review of methods for analysis in sea water, biota, and sediments
- No. 13 Biological effects of contaminants: Microplate method for measurement of ethoxyresorufin-O-deethylase (EROD) in fish
- No. 14 Temporal trend monitoring: Introduction to the study of contaminant levels in marine biota
- No. 15 Temporal trend monitoring: Contaminant levels in tissues of Atlantic cod
- No. 16 Benthic communities: Use in monitoring point-source discharges
- No. 17 Nutrients: Practical notes on their determination in sea water
- No. 18 Contaminants in marine organisms: Pooling strategies for monitoring mean concentrations
- No. 19 Common diseases and parasites of fish in the North Atlantic: Training guide for identification
- No. 20 Temporal trend monitoring: Robust method for analysing contaminant trend monitoring data
- No. 21 Chlorobiphenyls in marine sediments: Guidelines for determination
- No. 22 Biological effects of contaminants: Cholinesterase inhibition by organophosphate and carbamate compounds
- No. 23 Biological effects of contaminants: Determination of CYP1A-dependent mono-oxygenase activity in dab by fluorimetric measurement of EROD activity
- No. 24 Biological effects of contaminants: Use of imposex in the dogwhelk (*Nucella lapillus*) as a bioindicator of tributyltin pollution
- No. 25 Biological effects of contaminants: Measurement of DNA adducts in fish by ³²P-postlabelling
- No. 26 Biological effects of contaminants: Quantification of metallothionein (MT) in fish liver tissue
- No. 27 Soft bottom macrofauna: Collection, treatment, and quality assurance of samples