

---

**PATTERNS AND PROCESSES IN THE GENETIC STRUCTURE  
OF TWO MARINE NEMATODE TAXA  
(*RHABDITIS (PELLIODITIS) MARINA* AND *HALOMONHYSTERA DISJUNCTA*).**  
A MOLECULAR, MORPHOLOGICAL AND EXPERIMENTAL APPROACH.

---

Patronen en processen in de genetische structuur van twee mariene nematodentaxa  
(*Rhabditis (Pellioditis) marina* en *Halomonhystera disjuncta*).  
Een moleculaire, morfologische en experimentele benadering.



SOFIE DERYCKE

PROMOTOR: Prof. Dr. Tom Moens  
CO-PROMOTOR: Prof. Dr. Magda Vincx

Academic year 2006-2007



---

**PATTERNS AND PROCESSES IN THE GENETIC STRUCTURE  
OF TWO MARINE NEMATODE TAXA**

**(*RHABDITIS (PELLIODITIS) MARINA* AND *HALOMONHYSTERA DISJUNCTA*).**

A MOLECULAR, MORPHOLOGICAL AND EXPERIMENTAL APPROACH.

---

Patronen en processen in de genetische structuur van twee mariene nematodentaxa  
(*Rhabditis (Pellioditis) marina* en *Halomonhystera disjuncta*).  
Een moleculaire, morfologische en experimentele benadering.

---

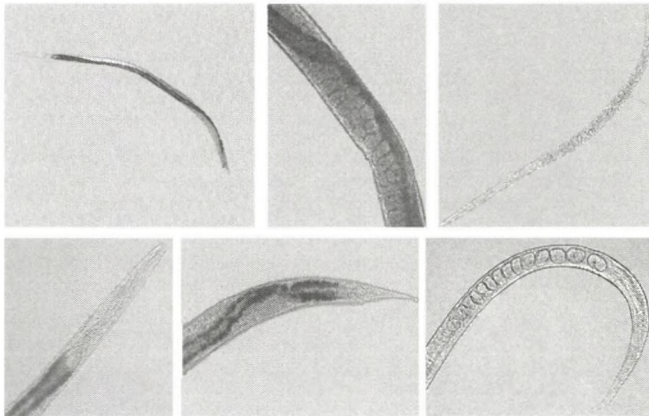

SOFIE DERYCKE

PROMOTOR: Prof. Dr. Tom Moens  
CO-PROMOTOR: Prof. Dr. Magda Vincx

Academic year 2006-2007

Thesis submitted in partial fulfillment of the requirements for the degree of  
Doctor in Science (Biology)

“If all matter in the universe except the nematodes were swept away, our world would still be dimly recognisable, and if, as disembodied spirits, we could then investigate it, we should find its mountains, hills, vales, rivers, lakes and oceans represented by a film of nematodes.”

Cobb, 1914

**PROMOTOR:** Prof. Dr. Tom Moens (Ghent University)  
**CO-PROMOTOR:** Prof. Dr. Magda Vincx (Ghent University)

**MEMBERS OF THE READING COMMITTEE:**

PROF. DR. PAUL DE LEY (UNIVERSITY OF CALIFORNIA, RIVERSIDE)  
PROF. DR. THIERRY BACKELJAU (ROYAL BELGIAN INSTITUTE OF NATURAL SCIENCES,  
BRUSSELS; UNIVERSITY OF ANTWERP)  
PROF. DR. TOM MOENS (GHENT UNIVERSITY)  
PROF. DR. MAGDA VINCX (GHENT UNIVERSITY)

**MEMBERS OF THE EXAMINATION COMMITTEE:**

PROF. DR. WIM VYVERMAN (CHAIRMAN, GHENT UNIVERSITY)  
PROF. DR. FILIP VOLCKAERT (CATHOLIC UNIVERSITY LEUVEN)  
PROF. DR. JACQUES VANFLETEREN (GHENT UNIVERSITY)  
PROF. DR. ANN VANREUSEL (GHENT UNIVERSITY)  
DR. THOMAS REMERIE (GHENT UNIVERSITY)

**THESIS DEFENDED IN PUBLIC:**

FRIDAY, MARCH 16<sup>TH</sup> 2007 AT 5.00 PM  
GHENT UNIVERSITY  
MULTIMEDIA ROOM, KRIJGSLAAN 281 (S9), B-9000 GHENT

**FINANCIAL SUPPORT:**

THIS THESIS WAS FINANCIALLY SUPPORTED THROUGH GHENT UNIVERSITY (BOF-PROJECTS B/00118-BOF 2-4 AND 01J13207) AND THE FLEMISH INSTITUTE FOR THE PROMOTION OF SCIENTIFIC - TECHNOLOGICAL RESEARCH (I.W.T.)

---

# TABLE OF CONTENTS

---

## DANKWOORD

Samenvatting .....	i
Summary .....	vii

## CHAPTER I GENERAL INTRODUCTION AND OUTLINE OF THE THESIS .....

1

The population genetic structure of a species .....	2
A few words about species complexes .....	6
Nematodes: what we know and don't know... ..	7
The research model .....	9
Aims and outline of the thesis .....	11

## CHAPTER II MITOCHONDRIAL DNA VARIATION AND CRYPTIC SPECIATION WITHIN THE FREE - LIVING MARINE NEMATODE *PELLIODITIS MARINA* .....

13

Abstract .....	16
Introduction .....	17
Material and Methods .....	19
Sample locations .....	19
Sample collection and processing .....	20
DNA extraction and PCR amplification .....	21
Single Strand Conformation Polymorphisms (SSCP) .....	22
DNA sequencing .....	22
Data analysis .....	23
Results .....	24
Intraspecific variation of COI .....	24
Phylogenetic analyses .....	26
Interspecific variation and geographical distribution .....	28
Population genetic structure .....	29
Isolation By Distance .....	31
Discussion .....	32
Population genetic structure .....	32
Cryptic speciation .....	33
Distribution of the four lineages .....	35
Conclusion .....	36
Acknowledgements .....	36

## CHAPTER III SEASONAL DYNAMICS OF POPULATION GENETIC STRUCTURE IN CRYPTIC TAXA OF THE *PELLIODITIS MARINA* COMPLEX (NEMATODA: RHABDITIDA) .....

41

Abstract .....	42
Introduction .....	43

<b>Material and Methods</b> .....	<b>45</b>
Sample locations and their ecological characteristics .....	45
Sample collection and processing .....	46
Generating the molecular data .....	46
Data analysis .....	47
<b>Results</b> .....	<b>51</b>
Genetic diversity and phylogenetic analysis .....	51
Spatiotemporal distribution of the four cryptic lineages (PmI, PmII, PmIII and PmIV) .....	51
Spatial versus temporal variation in haplotype frequencies within the four mitochondrial lineages .....	54
Spatiotemporal variation among haplotypes of the PmI lineage .....	55
<b>Discussion</b> .....	<b>57</b>
Genetic diversity and phylogenetic analysis .....	57
Spatiotemporal distribution of four cryptic lineages .....	58
Population genetic structure of PmI .....	59
<b>Conclusion</b> .....	<b>62</b>
<b>Acknowledgements</b> .....	<b>62</b>

**CHAPTER IV SPATIOTEMPORAL ANALYSIS OF POPULATION GENETIC STRUCTURE IN  
*GEOMONHYSTERA DISJUNCTA* (NEMATODA, MONHYSTERIDA) REVEALS HIGH  
LEVELS OF MOLECULAR DIVERSITY .....** **65**

<b>Abstract</b> .....	<b>66</b>
<b>Introduction</b> .....	<b>67</b>
<b>Material and methods</b> .....	<b>69</b>
Sample collection and processing .....	69
Molecular analysis .....	71
Data analysis .....	72
<b>Results</b> .....	<b>75</b>
Morphometric data .....	75
COI variation .....	75
Phylogenetic analysis .....	79
Distribution of the five Gd lineages .....	80
Population genetic structure .....	80
Temporal analysis of population genetic structure .....	82
<b>Discussion</b> .....	<b>83</b>
Molecular diversity in nematodes .....	83
Population genetic structure: spatial and temporal patterns .....	84
Taxonomy in marine nematodes .....	85
<b>Conclusion</b> .....	<b>87</b>
<b>Acknowledgements</b> .....	<b>87</b>

**CHAPTER V INTEGRATIVE TAXONOMY DISCLOSES HIDDEN DIVERSITY IN NEMATODES .....** **89**

<b>Abstract</b> .....	<b>90</b>
<b>Introduction</b> .....	<b>91</b>
<b>Material and Methods</b> .....	<b>93</b>
Taxonomical basis .....	93
Sampling and sample processing .....	94
Integrative taxonomy data analysis .....	95
<b>Results</b> .....	<b>99</b>
Molecular phylogenetic analysis .....	99
Multivariate morphometrics .....	100
Typology .....	101
Breeding experiments .....	102
<b>Discussion</b> .....	<b>103</b>
<b>Acknowledgements</b> .....	<b>107</b>

**CHAPTER VI DISENTANGLING TAXONOMY WITHIN THE *RHABDITIS (PELLIODITIS) MARINA* (NEMATODA, RHABDITIDAE) SPECIES COMPLEX USING MOLECULAR AND MORPHOLOGICAL TOOLS ..... 113**

<b>Abstract</b> .....	<b>114</b>
<b>Introduction</b> .....	<b>115</b>
<b>Material and Methods</b> .....	<b>117</b>
Sample collection and processing .....	117
Data analyses .....	120
<b>Results</b> .....	<b>123</b>
Molecular data: phylogenetic analysis of COI .....	123
Molecular data: phylogenetic analyses of the nuclear ITS and D2D3 regions .....	124
Morphological analyses .....	125
<b>Discussion</b> .....	<b>130</b>
Molecular results .....	130
Morphological results .....	131
Combining molecular and morphological results to infer taxonomic status of the 'cryptic' lineages within <i>R. (P.) marina</i> .....	132
<b>Conclusion</b> .....	<b>134</b>
<b>Acknowledgements</b> .....	<b>134</b>

**CHAPTER VII COLONISATION PATTERNS OF NEMATODA ON DECOMPOSING ALGAE IN THE ESTUARINE ENVIRONMENT: COMMUNITY ASSEMBLY AND GENETIC STRUCTURE OF THE DOMINANT SPECIES *PELLIODITIS MARINA* ..... 137**

<b>Abstract</b> .....	<b>138</b>
<b>Introduction</b> .....	<b>139</b>
<b>Material and methods</b> .....	<b>141</b>
Experimental setup and sampling .....	141
Processing of <i>Fucus</i> thalli .....	142
Nematode community .....	142
Molecular analysis of <i>P. marina</i> .....	143
Data analysis .....	144
<b>Results</b> .....	<b>146</b>
<i>Fucus</i> quality .....	146
Nematode abundances .....	146
Nematode community .....	147
Colonisation of <i>Fucus</i> by <i>P. marina</i> .....	149
Genetic patterns and diversity of <i>P. marina</i> .....	149
Colonisation dynamics of haplotypes .....	151
<b>Discussion</b> .....	<b>152</b>
Nematode community structure and abundance .....	152
Colonisation of <i>Fucus</i> by <i>P. marina</i> .....	153
Genetic patterns and diversity of colonising <i>P. marina</i> .....	153
<b>Conclusion</b> .....	<b>155</b>
<b>Acknowledgements</b> .....	<b>155</b>

**CHAPTER VIII EFFECTS OF SUBLETHAL ABIOTIC STRESSORS ON POPULATION GROWTH AND GENETIC DIVERSITY OF *PELLIODITIS MARINA* (NEMATODA) FROM THE WESTER-SCHELDE ESTUARY ..... 157**

<b>Abstract</b> .....	<b>158</b>
<b>Introduction</b> .....	<b>159</b>
<b>Material and methods</b> .....	<b>161</b>
Test organism and study population .....	161
Test conditions .....	162
Experimental design .....	162

Molecular analysis of population genetic diversity .....	165
Data analysis .....	165
<b>Results</b> .....	<b>167</b>
Population development .....	167
Genetic variation .....	169
<b>Discussion</b> .....	<b>173</b>
Population development .....	173
Genetic variation .....	174
<b>Conclusion</b> .....	<b>177</b>
<b>Acknowledgements</b> .....	<b>177</b>

**CHAPTER IX PHYLOGEOGRAPHY OF THE *RHABDITIS (PELLIODITIS) MARINA* SPECIES COMPLEX:  
EVIDENCE FOR COSMOPOLITANISM, RESTRICTED GENE FLOW, RECENT RANGE  
EXPANSIONS AND ACCELERATED EVOLUTION .....** **179**

<b>Abstract</b> .....	<b>180</b>
<b>Introduction</b> .....	<b>181</b>
<b>Material and Methods</b> .....	<b>183</b>
Sampling and genetic analysis .....	183
Data analysis .....	184
<b>Results</b> .....	<b>189</b>
Phylogenetic analysis .....	189
Phylogeography of the <i>R. (P.) marina</i> species complex .....	191
Spatial genetic structuring within the cryptic species .....	193
Phylogeography and demographic history of the cryptic species .....	194
Nested clade analysis of PmII .....	196
Haplotype diversity in PmII .....	198
<b>Discussion</b> .....	<b>199</b>
Micro-evolutionary processes affecting population genetic structure .....	199
Macro-evolutionary processes affecting radiation in and distribution of <i>R. (P.) marina</i> .....	202
<b>Conclusion</b> .....	<b>204</b>

**CHAPTER X GENERAL DISCUSSION .....** **207**

How important are biological characteristics in determining the population genetic structure of marine nematodes? .....	208
How to reconcile pronounced small-scale population genetic structure with a high potential for gene flow? .....	210
How can highly similar species coexist? .....	213
What evidence do we have for dispersal capacities in marine nematodes? .....	214
Is DNA-barcoding the solution for nematode identification? .....	215
Suggestions for future research .....	218

**CITED LITERATURE .....** **221**



## DANKWOORD

Joepie! Mijn doctoraat is af, en dat maakt me niet alleen ongelooflijk blij, maar het vervult me ook met bijzondere trots! De voorbije vijf jaren zijn ontegensprekelijk een bijzondere ervaring geweest, die mijn persootje hebben gesterkt en die mij bijzondere mensen hebben leren kennen! Die mensen hebben mij in allerlei aspecten van dit boekje geholpen, en ik heb steeds getracht om ze op het moment zelf mijn dankbaarheid te tonen. Toch zou ik hier graag van de gelegenheid gebruik willen maken om een aantal mensen extra in de bloemetjes te zetten!!

Eerst en vooral wil ik hier Prof. Dr. Magda Vincx vermelden, eerst mijn promotor en nu co-promotor, omdat je mij de tijd hebt gegeven om mij in dit onderzoek te laten groeien, maar vooral voor de grote vrijheid die je mij hebt gegeven om dit werk tot een goed einde te brengen!

Prof. Dr. Tom Moens, mijn co-promotor en nu promotor, jij bent veruit de belangrijkste persoon achter dit werk geweest. Je vindingrijkheid, inspiratie en wetenschappelijke ideeën zijn onuitputtelijk. Talrijke keren gaf je me de bevestiging die ik zocht als ik weer eens aan iets twijfelde, en je had altijd bemoedigende woorden klaar als de inspiratie eventjes ver te zoeken was. Maar bovenal heb je zo vaak gezegd 'Je bent zeer goed bezig' of 'Doe zo voort' en dat was de beste stimulans! Daarnaast heb je nog eens uren gependend om mijn teksten te lezen en te verbeteren, en je hebt me ook steeds laten doen wat ik wou doen. Oneindig dankbaar ben ik je voor al je hulp en ik wens je bijzonder veel succes toe in je verdere carrière! Doe zo voort ☺!

Verder zijn er nog drie andere kerels die voor mij enorm belangrijk zijn geweest. Dr. Thomas Remerie, jou wil ik bedanken voor de vele interessante discussies, voor het oplossen van vele moleculaire problemen, voor het doorgeven van je kennis, voor je morele hulp en voor het leuke samenwerken op alle vlakken! Bedankt voor alles! Andy Vierstraete, jij bent mijn moleculaire engel!! Je leerde me de kneepjes van het vak. Je bleef lachen en suggesties geven toen ik je wekenlang ten einde raad met talloze fotootjes zonder bandjes kwam bestoken. Bovendien heb je immens veel sequenceringswerk gedaan, wat mij op het laatste zeer veel tijd heeft uitgespaard! Echt waar heel erg bedankt voor alle praktisch hulp en voor de leuke momenten in het lab! Tenslotte wil ik Prof. Dr. Thierry Backeljau bedanken: zonder

## DANKWOORD

---

dat je ook maar enig belang in dit onderzoek had, beantwoordde je mijn talloze mails direct met kristalheldere oplossingen! Bovendien stond je deur steeds voor me open, en waren discussies met jou niet alleen bijzonder leerrijk, maar ook nog eens superstimulerend! Je kennis, ideeën, interesse, enthousiasme en hulpvaardigheid zijn niet te evenaren! Dat ik dit allemaal onder de knie heb gekregen is zeker mede dankzij jou! Bedankt!

Prof. Dr. Jacques Vanfleteren zou ik willen bedanken voor het ter beschikking stellen van zijn labo tijdens mijn eerste moleculaire stapjes, en de mensen in zijn labo, Bart B, Koen H, Kristel B, Isabelle L, David H, Sylvie V en in het bijzonder Annemie De Vreese, voor haar hulp en tips bij allerlei praktische probleempjes!

Statistiek, het is weinigen gegeven er mee te spelen, en ik ken gelukkig een paar mensen die het kunnen! Prof. Dr. Ann Vanreusel en Dr. Frederik Hendrickx, heel erg bedankt voor jullie hulp bij de dataverwerking van mijn experimentele stukken!

A very special thanks to Gustavo, for the many interesting discussions on morphological species delimitation, for your help with writing the morphological chapters, for the excellent drawings of our nematode species and for your immense interest in my work!

Mijn praktisch werk in het moleculair platform werden gedurende de laatste jaren steevast opgeluisterd door Ellen, Caroline, Heroen, Olivier, Sofie en Miet. Bedankt allemaal voor de aangenane en leuke werksfeer!

Heel wat mensen zijn zo vriendelijk geweest om stinkende, rottende wierpakketjes van over de hele wereld mee te brengen of op te sturen: bedankt Heroen V, Olivier D, Klaas P, Koen H, Gaetan B, Sofie V, Gert V, Annelies D, Bea M, Annick V, Tom M, Marleen D, Danielle S, Pieter P, Tim D, Magda V, Jan V, Sam D, Terry V en Hannelore W. Thank you Manuela, Jens, Reinhold and Karin for sending me samples!

Ik heb het geluk gehad een aantal enthousiaste thesisstudenten te hebben mogen begeleiden: bedankt Caroline, Roxane, Sofie en Lindsay! Ook mijn maandwerkstudenten Sasha, Barbara en Hanne verdienen hier zeker een vermelding.

Dat brengt mij dan bij de marbiol mensen. Dirk V heeft mij serieus geholpen door C/N analyses uit te voeren en chemische berekeningen te checken, Isolde D, Danielle S en Annick VK hebben zoveel bestellingen voor mij gedaan, en bovenal, Annick voor de vele nematoden die je in preparaat hebt gebracht. En zeker niet minder belangrijk, wil ik jullie samen met Guy D ook bedanken voor de talloze leuke labo-feestjes en recepties die jullie op poten hebben gezet! Guy, jij verdient hier een extra plaatsje voor het oplossen van onverklaarbare computerproblemen en voor de leuke babbels onder iets minder serieuze omstandigheden! In het bijzonder wil ik Ilse De Mesel bedanken, voor je hulp, geduld en enthousiasme toen ik mijn licentiaatsthesis bij je maakte en later, toen ik aan dit werk begon, voor alle begrip en steun die je me hebt gegeven! Je begreep me perfect als het eventjes tegen zat, wist wat je moest zeggen om verder te doen en je was een schat om mijn gedachten te verzetten! Ik wens je dan ook met mijn volle hart alle geluk toe met je nieuwe carrière en in je nieuw huis! Dat laatste geldt eveneens voor Annick Ve, bezig bijtje dat je bent, en voor mijn bureaugenootjes Saskia, Sofie en Julie, alle vier wens ik jullie supergezonde kindjes toe, al kan dat bijna niet anders na onze wekelijkse zwempartijtjes! Trouwen, baby's, pampers, het zegt me nog steeds niets, maar ik heb het gevoel dat ik zeker goed voorbereid zal zijn mocht het ooit keren ☺ Merci voor al jullie levenswijsheid!

Ik heb bovenal het geluk gehad fantastische vrienden rond mij te hebben. Jullie zijn de beste strategie om mijn gedachten te verzetten, om alles te relativieren en om... te lachen! Mijn 'Bladluis' bende uit Poperinge zou ik voor geen goud ter wereld willen en kunnen missen! Jullie interesse voor mijn wormpjes heeft me meerdere malen ontroerd (mijn doop indachtig zijnde mag dit zelfs heel letterlijk genomen worden)! Dat ons 'Bladluis' bendeke blijft samenhangen lang na onze studententijd vind ik fantastisch en ik hoop dat onze vriendschap nog vele jaren mag blijven bestaan! Dat geldt ook voor 'de bende van Gent'. Met heel veel enthousiasme hebben jullie wier van talrijke plaatsen meegebracht en waren jullie bijzonder geïnteresseerd in het verloop van mijn doctoraat! Vrijdagavonden zonder jullie, ik mag er niet aan denken! Bedankt Birgit, Tascha en Koen, Liesbet en Geert, Natalie en Stefan, Stijn en Saskia, Frank en Joke, Bieke, Dieter en Evelyne, Anneke en Steven, Sam en Katrien, Terry en Lore, Lieven en Marie, Thomas en Robrecht voor de talloze leuke babbels

## DANKWOORD

---

tussen pot en pint! En voor Natalie, Frank en Anneke: heel veel succes met jullie doctoraat!

De belangrijkste mensen komen in zo'n dankwoordje altijd het laatst, en het is hier niet anders. Mama en papa, bedankt voor het schitterende leven dat jullie mij hebben gegeven en voor alle hulp, steun en vertrouwen! Mijn 'schoon'familie, voor hun ongelooflijke interesse en voor het meebrengen van wier uit verschillende plaatsen in Frankrijk!

En helemaal laatst, natuurlijk, mijn kep! Van alle mensen die ik wil bedanken ben jij de allerbelangrijkste! Je bent mijn beste en liefste tegenpool, en bovenal, de enige die mij in zoveel drukte zo perfect tot rust kan brengen! Dat dit boekje er uitziet zoals ik het wou, heb ik helemaal aan jou te danken! Vanaf nu zal ik opnieuw koken, afwassen en kuisen! Al blijft zoiets natuurlijk wel leuker met twee, hé?

3 maart 2007

Sofie Derycke

---

**SAMENVATTING**

**SUMMARY**

---

## SAMENVATTING

Nematoden vormen één van de meest soortenrijke en ecologisch meest succesvolle fyta op aarde (Heip et al. 1985, Lamshead 2004), waarbij schattingen van het aantal nematodensoorten rond  $10^6$  draait (Heip et al. 1985, Boucher & Lamshead 1995, Coomans 2000). Het fylum bevat zowel parasitaire als vrijlevende soorten, en vooral deze laatste kunnen in zeer hoge densiteiten in bodems en sedimenten van kustgebieden en estuaria voorkomen (Heip et al. 1985). Door hun geringe grootte ( $< 1$  mm) en de afwezigheid van pelagische larven of andere dispersieve stadia wordt algemeen aangenomen dat vrijlevende mariene nematoden een zeer geringe dispersiecapaciteit bezitten. Anderzijds kunnen nematoden in de waterkolom gesuspendeerd geraken door de werking van het getij, waardoor passieve dispersie via waterstromingen aanzienlijk zou kunnen zijn (Fegley 1987, Wetzel et al. 2002). Directe bewijzen hiervoor zijn tot nu toe echter niet voor handen. Sommige nematodensoorten hebben een wereldwijde verspreiding, wat suggereert dat hun dispersie substantieel kan zijn. Bij nader onderzoek is echter veelal gebleken dat geografisch verafgelegen populaties subtiele verschillen in morfologie, fysiologie en reproductie kunnen vertonen. Alhoewel dit een gevolg kan zijn van lokale adaptatie, kan het net zo goed een indicatie zijn voor het bestaan van cryptische soorten, i.e. soorten die sterke genetische verschillen vertonen maar die morfologisch niet van elkaar te onderscheiden zijn. Dergelijke cryptische soorten zijn reeds in heel wat mariene organismen waargenomen (Knowlton 1993, 2000). De morfologische identificatie tot op soortniveau is bij vrijlevende nematoden zeer moeilijk. Vaak zijn de soortspecifieke kenmerken zo minuscuul dat er gesofisticeerde apparatuur, zoals bijvoorbeeld een elektronenmicroscop, dient gebruikt te worden om ze te kunnen waarnemen en kan enkel een expert de soort correct identificeren (De Ley et al. 2005). De combinatie van deze identificatieproblemen en de schijnbaar wereldwijde verspreiding ondanks de beperkte dispersiecapaciteit doen vermoeden dat cryptische diversiteit binnen vrijlevende nematoden aanzienlijk kan zijn. Moleculaire studies, en meer specifiek populatie genetische studies, in vrijlevende nematoden zijn alsnog zeer schaars (bv. Sivasunder & Hey 2005). Nochtans kan het in beeld brengen van de genetische variatie tussen en binnen populaties van een soort belangrijke informatie verschaffen over de dispersiecapaciteit van die soort. Indien alle genetische variatie

vervolgens onderworpen wordt aan een fylogenetische analyse<sup>1</sup> kan dit leiden tot de ontdekking van cryptische soorten. Er wordt vaak verondersteld dat de populatie genetische structuur constant blijft, waardoor de effecten van toevalsfactoren en van gerichte processen zoals selectie genegeerd worden (Heath et al. 2002, Arnaud & Laval 2004). Nochtans zijn soorten die leven in de intertidale gebieden van kusten en estuaria onderhevig aan sterke fluctuaties in fysische krachten en abiotische factoren (Bilton et al. 2002, Kelly et al. 2006). Het optreden van temporele verschillen in populatie genetische structuur kan dus mogelijk zijn, en een temporele analyse kan bovendien informatie verschaffen over metapopulatiodynamieken in de soort (Hoffman et al. 2004).

In dit doctoraatsproefschrift werd een populatie genetische studie uitgevoerd van twee vrijlevende, mariene nematodensoorten, namelijk *Rhabditis (Pellioiditis) marina* en *Halomonhystera disjuncta*. Hierbij was het hoofddoel informatie te verkrijgen over 1) de dispersiecapaciteiten, 2) de cryptische diversiteit en 3) de intra- en interspecifieke genetische variatie en na te gaan of 4) de genetische structuur in beide soorten beïnvloed werd door metapopulatiodynamieken.

*R. (P.) marina* en *H. disjuncta* werden ingezameld langsheen de Belgische kust en in Zuidwest-Nederland. Op deze beperkte geografische schaal van ca. 100 km werden nematoden verzameld in verschillende types van habitat (kustzones, estuarium, semi-estuarium en zelfs in een zoutwater meer). Deze habitats verschilden in hun onderlinge connectiviteit, waarbij het Grevelingenmeer als volledig geïsoleerd kan beschouwd worden, en de Oosterschelde enkel sporadisch van de Noordzee wordt afgesloten door het gebruik van de Stormvloedkering, terwijl uitwisseling tussen alle andere habitattypes in principe niet belemmerd wordt. In totaal werden negen verschillende locaties bemonsterd waarbij telkens 50 individuen werden geïsoleerd voor moleculaire analyses. Deze negen locaties werden voor *R. (P.) marina* in vier opeenvolgende seizoenen bemonsterd, terwijl *H. disjuncta* in twee seizoenen werd ingezameld. Op die manier werd de genetische variatie in het mitochondriale cytochrome oxidase c subunit 1 (COI)-gen in 1615 individuen van *R. (P.) marina* en in 759 individuen van *H. disjuncta* bestudeerd met behulp van de single strand

---

<sup>1</sup> Fylogenetische analyse = onderzoek naar de evolutionaire verwantschappen

conformation polymorphism<sup>2</sup> (SSCP) methode. De populatie genetische structuur was opvallend vergelijkbaar voor beide soorten en duidde op een grote divergentie in het COI gen. Deze divergentie varieerde van 0.25 % tot 10.6 % in *R. (P.) marina* en van 0.25 % tot 24.8 % in *H. disjuncta*. De fylogenetische analyses toonden aan dat de COI haplotypes van beide soorten opgedeeld werden in duidelijk afgebakende groepen: voor *R. (P.) marina* konden vier en voor *H. disjuncta* vijf groepen worden onderscheiden. De variatie binnen elk van deze groepen was laag en zelden hoger dan 2 %. Van elke mitochondriale groep werd vervolgens van een aantal individuen ook een nucleair fragment geamplificeerd en onderworpen aan dezelfde fylogenetische analyses. Opnieuw werden dezelfde duidelijke groepen teruggevonden. De soortstatus van deze genetische groepen werd verder onderzocht aan de hand van een geïntegreerde aanpak op basis van morfologische metingen en (preliminaire) kruisingsexperimenten. De klassieke taxonomische methode leidde tot een sterke onderschatting van de werkelijke diversiteit in nematoden. Meteen werd ook duidelijk dat de zeer populaire DNA-barcode<sup>3</sup> methode geschikt kan zijn als identificatiemiddel, maar problematischer is voor het afbakenen van nieuwe soorten. Ondanks het feit dat het COI-gen alle soorten correct identificeerde, was er een duidelijk verschil tussen de divergentiewaarden in *R. (P.) marina* en in *H. disjuncta*. De fylogenetische groepen binnen *R. (P.) marina* vertoonden een gemiddelde divergentie van 8 %, terwijl dit tussen groepen binnen *H. disjuncta* opliep tot 24.8 %. Als vuistregel worden fylogenetische groepen als soorten bestempeld wanneer hun divergentie tienmaal hoger ligt dan de intraspecifieke variatie. Dit betekent dat geen enkele soort binnen het *R. (P.) marina* complex zou geïdentificeerd zijn met deze regel. De betrouwbaarheid van het systeem neemt sterk toe wanneer twee onafhankelijke moleculaire merkers bekeken worden en soorten worden afgebakend op basis van de overeenkomsten tussen beide merkers. Een dergelijk systeem lijkt dan ook een veelbelovende eerste stap voor het bepalen van diversiteit in taxa die morfologisch moeilijk te identificeren zijn. Niettemin bestaat het meest robuuste systeem voor soortenidentificatie zowel uit moleculaire, morfologische als

---

<sup>2</sup> letterlijke vertaling= enkelstrengige structuur van de genetische variant. Principe: elke specifieke volgorde van nucleotiden resulteert in een unieke 3-dimensionele opvouwing die in een elektrisch veld met een bepaalde snelheid door een acrylamide gel zal migreren. Dit resulteert in specifieke bandenpatronen voor een bepaalde sequentie.

<sup>3</sup> De DNA-barcode methode gebruikt een snelle, adequate en automatische identificatie van soorten op basis van één enkel stukje DNA (COI).



biologische data. De abundanties van elke cryptische soort vertoonden seizoensale verschillen in elke locatie. Dit zou kunnen wijzen op verschillende abiotische preferenties/toleranties van de cryptische soorten.

Voor elke cryptische soort werden genetische verschillen tussen populaties statistisch getest. In alle soorten die op meer dan één plaats werden aangetroffen kon een significante structurering, i.e. verschillen in haplotypesamenstelling tussen populaties, worden waargenomen. Dit suggereerde dat dispersie van deze nematodensoorten zeer beperkt is. De biologische (e.g. generatietijd) en ecologische (e.g. habitat preferenties) verschillen tussen *R. (P.) marina* en *H. disjuncta* hadden bovendien weinig invloed op de genetische structuur. De genetische structurering bleek echter sterk te variëren in de verschillende seizoenen, wat eerder wijst op metapopulatiodynamieken dan op een beperkte dispersiecapaciteit. Wierpakketten vormen immers geen continue habitat maar hebben een zeer 'patchy' verspreiding. Bovendien zorgt het intergetijden milieu voor sterke schommelingen in abiotische factoren, waardoor het bemonsterde habitat zeer onstabiel is. Dit benadrukt nog maar eens het belang van temporele studies en van de kennis van levensgeschiedenis-kenmerken voor het correct interpreteren van de populatie genetische structuur van soorten.

De genetische structuur die we vandaag waarnemen in soorten is het resultaat van zowel historische als hedendaagse processen. Deze werden bestudeerd aan de hand van een fylogeografische studie en experimenten, respectievelijk. In een eerste (veld) experiment werd nagegaan in welke mate kolonisatiedynamieken de genetische compositie van epifytische populaties kunnen beïnvloeden. Hiervoor werden gedefaundeerde *Fucus* fragmenten in het veld geïncubeerd in twee verschillende plaatsen: site A lag te midden van natuurlijk *Fucus* materiaal dat vastgehecht was aan stenen, terwijl site B op minstens 100 m van elke mogelijke bronpopulatie was verwijderd. Zoals verwacht werd het wier in site A sneller gekoloniseerd en leek de genetische samenstelling zeer sterk op die van de nabije bronpopulatie. De wierfragmenten in site B werden echter gedomineerd door haplotypes die zeldzaam waren in de natuurlijke bronpopulatie. Bovendien was ook de haplotype diversiteit significant lager in het wiermateriaal van site B dan in dat van site A. Dit toonde duidelijk aan dat kolonisatiedynamieken een zeer sterke invloed kunnen hebben op de uiteindelijke samenstelling van de populatie. Verder werd ook duidelijk dat haplotypes die het wiermateriaal eerst koloniseerden zo goed als volledig de haplotype samenstelling op het eind van het experiment bepaalden. Dit wees op de

sterke invloed van prioriteitseffecten op de genetische samenstelling van nematodenpopulaties.

In een tweede experiment werd nagegaan of suboptimale omstandigheden in combinatie met sublethale Cd-concentraties een respons op genetisch niveau kunnen veroorzaken bij *R. (P.) marina*. Dit labo-experiment is gebaseerd op waarnemingen in het veld, waarbij *R. (P.) marina* een lagere genetische diversiteit vertoonde in een locatie met een lagere saliniteit en hogere pollutie dan de andere bemonsterde locaties. Verwacht werd dat een reductie in populatie-ontwikkeling zich verder zou uiten in een lagere genetische diversiteit (genetische bottleneck). De ontwikkeling van de populaties onder verschillende saliniteiten en Cd-concentraties werd gedurende veertien dagen dagelijks gevolgd, en de genetische diversiteit werd bepaald in de F1, F2 en F5 generatie. Er werd initieel een lagere genetische diversiteit waargenomen bij lagere saliniteiten, maar dit effect bleef niet bestaan tot in de F5 generaties. Sublethale Cd-concentraties belemmerden de populatie-ontwikkeling in de treatments met suboptimale saliniteiten, maar dit resulteerde dus niet in een daling in de genetische diversiteit. Dit experiment toonde ook duidelijk aan dat lokale adaptatie en cryptische diversiteit zeer belangrijk kunnen zijn voor een correcte interpretatie van ecotoxicologische responsen in estuariene populaties.

De effecten van historische processen werden tenslotte bestudeerd aan de hand van een fylogeografische studie in *R. (P.) marina*. Er werden stalen ingezameld in West-Europa, NO-Amerika, Mexico, Zuid-Afrika en Australië en opnieuw werd gekeken naar de variatie in het COI-gen. Op deze grote ruimtelijke schaal werden tien cryptische soorten waargenomen, en slechts drie hiervan werden (nog) niet teruggevonden in de eerste kleinschalige populatie genetische studie in België en Nederland. In alle soorten werd een sterke genetische structurering waargenomen en er was een duidelijke opsplitsing tussen populaties ten noorden en ten zuiden van de Britse eilanden. De fylogeografische patronen in de meest wijdverspreide cryptische soort van het *R. (P.) marina* soortencomplex (PmII) wezen naar een afname van diversiteit met toenemende breedtegraad wat in overeenstemming is met koloniaties en compressies in het verspreidingsgebied van soorten gedurende glaciaties. Algemeen wordt immers aangenomen dat soorten in gematigde noordelijke gebieden teruggedrongen werden naar het zuiden als gevolg van de sterke temperatuurdalingen die gepaard gingen met de glaciaties. In de warmere periodes na de glaciaties konden deze soorten dan snel terug naar het noorden migreren. Het signaal van minstens twee

postglaciale, noordwaartse populatie-expansies waren terug te vinden en het zuidelijk deel van de Noordzee fungeerde waarschijnlijk als contactzone na de opening van het Engels kanaal. Verder toonde de fylogeografische analyse aan dat gene flow op deze grote ruimtelijke schaal beperkt was, maar dat occasionele lange afstandskolonisatie niet uitgesloten was. We vonden overtuigende bewijzen voor een kosmopolitische verspreiding van een aantal nematodensoorten. De berekeningen op basis van de expansieparameters in PmII suggereerden dat de mutatiesnelheid van COI in nematoden tien keer hoger was dan de algemeen aanvaarde moleculaire klok van 2 %. Aangezien de divergenties tussen de verschillende cryptische soorten gemiddeld 8 % waren, wees dit er op dat de speciatie in *R. (P.) marina* gebeurde ver voor de laatste ijstijd. Ook de splitsing tussen de Atlantische soorten en de enige cryptische soort aangetroffen in de Middellandse Zee was ouder dan het moment waarop de verbinding tussen de Middellandse Zee en de Atlantische Oceaan werd verbroken. Deze ingrijpende fenomenen waren dus niet de oorzaak van de radiatie binnen *R. (P.) marina*. Aangezien de meeste cryptische soorten min of meer beperkt zijn tot een bepaalde regio, werd een allopatrisch speciatie<sup>4</sup> patroon voorgesteld. De beperkte gene flow op grote geografische schaal strookte met een dergelijk patroon. Het samen voorkomen van soorten zou dan het gevolg zijn van toevallige lange afstandskolonisatie.

Samenvattend kunnen we stellen dat de studie van de populatie genetische structuur in zowel *R. (P.) marina* als *H. disjuncta* heeft geleid tot de ontdekking van een groot aantal cryptische soorten. De kleinschalige genetische structuring wordt veroorzaakt door hoge populatiedynamieken karakteristiek voor populaties in de intergetijdenzone en niet door beperkte gene flow. Op grote ruimtelijk schaal lijkt gene flow wel beperkt te zijn, wat mogelijk het belangrijkste macro-evolutionaire proces is. Verder werd empirisch aangetoond dat kolonisdynamieken belangrijke micro-evolutionaire processen zijn en dat de populatie-ontwikkeling kan belemmerd worden door sublethale Cd concentraties in combinatie met suboptimale saliniteiten. Ondanks de reductie in populatiegrootte werd geen permanente reductie in genetische diversiteit waargenomen. De fylogeografische studie toont aan dat de effecten van Pleistocene glaciaties in de hedendaagse genetische structuur van soorten kan worden teruggevonden en dat nematodensoorten kosmopolitisch kunnen zijn.

---

<sup>4</sup> Allopatrische speciatie = soortsvorming als gevolg van geografische isolatie

## SUMMARY

Nematodes are the most abundant metazoans on earth with estimates of total species numbers ranging up to  $10^6$  (Heip et al. 1985, Boucher & Lambshhead 1995, Coomans 2000). Free-living nematodes typically outnumber other meiofauna organisms in benthic habitats of coasts and estuaries (Heip et al. 1985). Their dispersal capacities are generally thought to be very limited because they lack pelagic larvae or other dispersive stages. On the other hand, passive dispersal through water currents (Fegley 1987, Wetzel et al. 2002), waterfowl or ballast water is plausible but hitherto poorly studied. Several marine nematode species show a wide to nearly cosmopolitan distribution, but geographically distant populations may differ in physiology, reproduction and even morphology. Nematode identification is complicated because the detection of important morphological features often requires high resolution microscopy and expert knowledge (De Ley et al. 2005). The combination of these characters suggests that cryptic diversity within marine nematodes may be high. Population genetic studies provide important information on genetic variation within and connectivity between populations, and frequently cryptic taxa are discovered. There is thus an urgent need for information on the population genetic structure and cryptic variation within morphologically defined nematode species. An accurate interpretation of the population genetic structure requires, however, also an assessment of temporal variability because stochastic and/or directional effects may alter allele frequencies over time (Heath et al. 2002, Arnaud & Laval 2004). Species living in the intertidal are subjected to strong physical and abiotic factors rendering temporal fluctuations in the population genetic structure likely (Bilton et al. 2002, Kelly et al. 2006). In turn, information on temporal changes in genetic structure may reveal to what extent natural populations of species exist in dynamic metapopulations (Hoffman et al. 2004).

In the present study, the population genetic structure of two free-living marine nematode species, *Rhabditis (Pellioditis) marina* and *Halomonhystera disjuncta*, was analysed. The principal aims were to explore 1) dispersal capacity, 2) cryptic diversity and 3) intra- and interspecific molecular variation and to investigate 4) to what extent metapopulation dynamics govern genetic structuring in both species.

*R. (P.) marina* and *H. disjuncta* were sampled on a fairly small and continuous geographical scale of ca. 100 km along the Belgian and Dutch coastline. Nematodes

were collected in a number of habitats (coast, estuary, coastal lagoon and lake) with different degrees of connectivity in Belgium and The Netherlands. We screened molecular variation in the mitochondrial COI gene in four consecutive seasons for *R. (P.) marina* (1615 individuals) and in two seasons for *H. disjuncta* (759 individuals) using the Single Strand Conformation Polymorphism (SSCP) method. At least four and five highly divergent lineages within *R. (P.) marina* and *H. disjuncta* were found, respectively. COI variation in *R. (P.) marina* ranged between 0.25 % and 10.6 %, and between 0.25 % and 24.8 % in *H. disjuncta*. Within-lineage variation was for both morphospecies typically lower than 2 %. The species status of the mitochondrial lineages was tested against nuclear gene trees, morphological data and interbreeding data. This integrative approach showed that current taxonomy grossly underestimates the true diversity within the phylum Nematoda. It also illustrated some of the problems associated with a DNA-barcoding method for the identification of new species. The level of divergence between cryptic species within *R. (P.) marina* (10.6 %) and within *H. disjuncta* (24.8 %) differed considerably. The threshold level to delineate species based on sequence divergence is currently set at ten times the intraspecific variation. Consequently, not a single species in the *R. (P.) marina* complex would have been detected. A DNA-barcode with two independently evolving molecular markers may, however, be a helpful tool for screening biological diversity, especially in taxa with complex morphology. Nevertheless, a solid framework to test species status clearly gained power when also morphological and biological data were considered.

The abundance of each species in both morphospecies largely fluctuated over time and may reflect different abiotic preferences. Population genetic structure was very similar between lineages of *R. (P.) marina* and *H. disjuncta*, and indicated that other factors than life-history characteristics influenced the genetic structuring. It also suggests that dispersal of nematodes on macroalgae was low. Our temporal analyses illustrated, however, that the population genetic structure was not stable over time. The observed genetic structuring in epiphytic nematode populations was best explained by metapopulation dynamics, rather than by life-history characteristics. These results highlighted the importance of temporal surveys as well as of knowledge on colonisation potential of species for a correct interpretation of their population genetic structure.

Finally, we used a combination of experimental and phylogeographic studies to unravel and distinguish effects of contemporary and historical processes on the genetic structure of cryptic species within *R. (P.) marina*. First, the effects of colonisation dynamics on the genetic composition of *R. (P.) marina* were examined in a field experiment. *Fucus* thalli free of epiphytic life were incubated at two contrasting sites in the field: site A was situated amidst permanent *Fucus* stands which permanently harbour *R. (P.) marina*, while site B was approximately 100 m away from any source population and experienced more stressful environmental conditions. As expected, the algal deposits at site A were more rapidly colonized and reached fivefold higher nematode densities than those in site B. Genetic composition, measured as mitochondrial COI diversity, in patches at site A resembled the source population, while rare haplotypes were abundant and genetic diversity was lower at site B. This indicated that bottlenecks affected the genetic composition in site B more than in site A. Colonisation dynamics did clearly have strong effects on the genetic structure of epiphytic nematodes. The genetic composition at both sites was also influenced by priority effects: the first haplotypes arriving at the patches determined the genetic composition throughout the experiment.

Secondly, we performed a laboratory experiment to investigate whether suboptimal environmental conditions may induce responses at the genetic level. This experiment was based on the observation that *R. (P.) marina* was genetically less diverse at the single location in the Westerschelde that experienced lower salinities and higher pollution. We followed the development of genetically diverse *R. (P.) marina* populations under experimental conditions during 14 days and assessed COI diversity in the F1, F2 and F5 generation. Results showed that low salinity conditions induced responses at the genetic level, but these were not stable over generations. Sublethal Cd concentrations reduced population development of *R. (P.) marina* at suboptimal salinities, but this did not result in genetic differences among treatments. Our data further showed that knowledge on environmental history and cryptic diversity is essential for a correct interpretation of ecotoxicological responses in estuarine populations.

The effects of historical processes on the present-day genetic structure of *R. (P.) marina* was investigated with a phylogeographic study along coasts in Western Europe, NE America, Mexico, South Africa and Australia. This survey suggested three additional cryptic species within the *R. (P.) marina* complex. Strong genetic

structuring was observed in all species and a clear genetic break was found around the British Isles. There was evidence for two postglacial, northwards orientated expansion events in PmII and for restricted gene flow with occasional long-distance dispersal. Our data also pointed to a contact zone in the Southern Bight of the North Sea. Clearly, historical patterns have affected the genetic structure of the species in the *R. (P.) marina* complex. We found evidence for a true cosmopolitan distribution of some nematode species which most probably resulted from occasional long-distance dispersal. In addition, we found that the COI mutation rate in *R. (P.) marina* is about ten times higher than the generally applied molecular clock of 2 %. Consequently, the speciation events in *R. (P.) marina* predate the last glacial maximum and the closure of the Strait of Gibraltar. We therefore hypothesized that the cryptic radiation in *R. (P.) marina* largely was the result of allopatric speciation due to restricted gene flow, and that the contemporary sympatric distribution resulted from occasional random long-distance dispersal.

In conclusion, the spatiotemporal population genetic structure in *R. (P.) marina* and *H. disjuncta* lead to the discovery of a large amount of cryptic diversity within both nominative species. On a scale of ca. 100 km, a pronounced genetic structuring was observed, which was caused by the high population dynamics of unstable and patchily distributed populations in the intertidal rather than by restricted gene flow. At larger geographical scales, gene flow was restricted, and may be the most important macro-evolutionary process. We further provided empirical evidence for the importance of colonisation dynamics as micro-evolutionary processes and showed that sublethal stressors under suboptimal conditions may induce reductions in population development. This did not result in a persistent reduction of genetic diversity, but may be indicative for effects of genetic drift under longer exposure times. The phylogeographic study provided evidence for the impact of historical events on the genetic structure of the *R. (P.) marina* complex and for the cosmopolitanism of at least some nematode species.

118952

---

**CHAPTER I**

**GENERAL INTRODUCTION AND OUTLINE OF THE THESIS**

---



### *THE POPULATION GENETIC STRUCTURE OF A SPECIES*

Virtually all species on earth are distributed heterogeneously across its surface. This aggregation of individuals correlates with environmental patchiness, in which areas of suitable habitat are intermixed with unsuitable habitat. Consequently, individuals from the same area are more likely to breed with each other than with individuals from distant areas. This non-random mating behaviour will ultimately lead to differences in gene frequencies between separate areas. *Genes* essentially are the physical entity that is transmitted from generation to generation during reproduction. They encode a variety of biochemical and physiological processes and essentially form the framework of life. The different types of a specific gene are called *alleles* and the total DNA present in a cell is referred to as the *genome*. As such, the study of allele frequencies between and within 'local interbreeding units' (we refer to this as the population throughout this thesis) gives a blueprint of *the genetic structure* of a species (Hartl 2000).

#### **Given this definition, what does the genetic structure of a species tell us?**

The population genetic structure of a species unravels important information on evolutionary mechanisms by which genetic variation is maintained and on the processes by which intraspecific genetic variation transforms into genetic divergence between species. Furthermore, it provides information on population history, migration patterns and dispersal abilities of species. The genetic information may further help to identify species that are morphologically difficult to distinguish and to discern effects of chemical, biological and environmental stress on the population. When a population genetic study is simultaneously performed in different species with contrasting life-histories, population sizes or breeding structure, the effects of those different characteristics on the genetic variation within species may be elucidated. In addition, the genetic differences between species may determine their ancestral history and may trace the origin of specific adaptations (Hartl 2000).

Clearly, the population genetic structure provides a wealth of information, but **what are the processes leading to differential allele frequencies between populations?** Within natural populations, allele frequencies are affected by *directional* or *chance* processes. Mutation, migration, drift and natural selection are the driving forces of differential allele frequencies. The ultimate source of new genetic variation are *mutations* which include substitutions, recombination, horizontal

gene transfer, insertions and deletions of nucleotides, but also chromosomal rearrangements. Generally, any particular mutation is rare and this process alone cannot account for large changes in allele frequencies over one generation (Fig 1.1). Rather, changes in allele frequency are largely dependent on the migration of individuals between populations, on natural selection and/or genetic drift (Hartl 2000). *Migration* is the movement of individuals between populations, and when followed by successful reproduction of the newly arriving immigrants (= *effective migration*), it may homogenise differences in allele frequencies between the source population and the newly invaded population. The frequency of new mutations may, however, also increase in a population through immigration/emigration of individuals (Fig 1.1). Alternatively, allele frequencies may change through the differential survival and/or reproductive success of individual organisms. Individuals that are better adapted to their environment will pass a greater proportion of their genes to the next generation (Fig 1.1). This process is referred to as *natural selection*. Contrary to these directional processes, *genetic drift* is a completely random process that affects all populations, but is particularly important in small populations. Therefore, the effects of genetic drift are enhanced in populations that have passed through a bottleneck or a founder event. Just by chance, some genes more often will be passed on to the next generation than others (Fig 1.1).

Another major factor shaping the present day patterns in the genetic structure of a species is its evolutionary history. Vicariance events have isolated populations and have led to restricted gene flow. Climatic changes have shifted distribution ranges back and forth, especially so in northern temperate species. During glacial periods, species were forced to southern latitudes due to low temperatures in the north. The warmer interglacial periods led to a rapid northwards migration into suitable habitats. These waves of colonisation and compression of distribution ranges profoundly influenced the levels of population differentiation and northern populations are generally less diverse than their southern counterparts (Hewitt 2000, Bernatchez & Wilson 1998). As such, the present day patterns in the genetic structure are the result of contemporary and historical events.

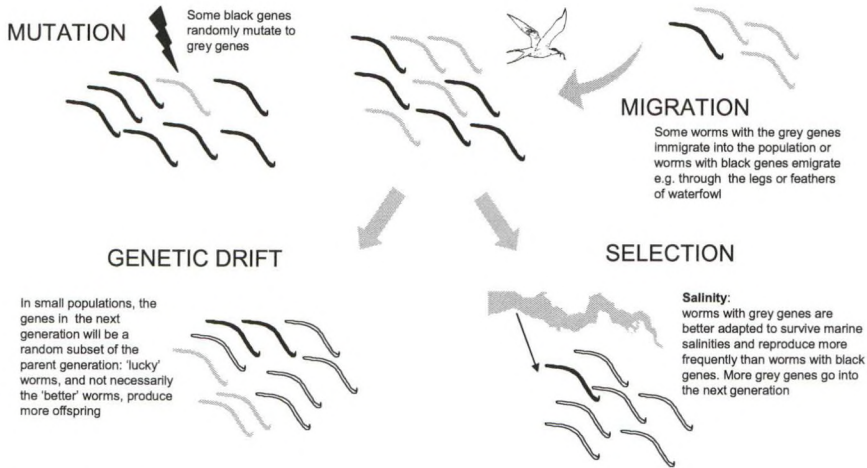

**Fig 1.1.** Mechanisms that alter gene frequencies in populations. The figure is based on <http://evolution.berkeley.edu/evosite/evo101/IIIBMechanismsofchange.shtml>. Black worms are homozygous for the black gene, white worms are homozygous for the grey gene and grey worms are heterozygous.

Now that we know how allele frequencies may change, **what patterns of genetic structure have been observed in the marine and estuarine environment?** Barriers to gene flow in the marine environment are mostly invisible. Moreover, many marine species, especially invertebrates, have biological traits that produce large-scale dispersal abilities, like broad-cast spawning and the production of planktotrophic larvae. The alleged absence of geographical barriers in seas and oceans and the high dispersal capacity of many marine organisms have led to predictions of little genetic structure over large spatial scales (Palumbi 1992). An increasing number of studies are challenging this dispersal paradigm by illustrating that many marine species with broad-scale dispersal abilities are in fact genetically structured (Barber et al. 2002, Peijnenburg et al. 2004, Luttikhuizen et al. 2003, Ovenden et al. 2004). The strength of this genetic structure ranges from isolation by distance (Maier et al. 2005) to sharp haplotype clines (Taylor & Hellberg 2003) and renders any correlation between dispersal potential and gene flow at best unpredictable. This paradox may be explained by the local retention of larvae (Cowen et al. 2000, Taylor & Hellberg 2003)<sup>5</sup>. Nevertheless, even in species occurring in the same biogeographical ranges and with similar dispersal capacities, remarkably different degrees of geographic structure have been found (Rocha et al. 2005, Rundle et al. 2000). As a result, factors

<sup>5</sup> See Introduction Chapter 2

other than dispersal capacity and geography may influence the genetic structure of marine species, e.g. ocean currents and geographic distances (Lessios et al. 1998). Phylogeographical studies in marine organisms have illustrated the importance of historical events, like Pleistocene glaciations (e.g. Coyer et al. 2003, Gysels et al. 2004, Remerie et al. 2006b), while other studies have demonstrated that ecological preferences may be at the core of the genetic structuring and speciation in the marine environment (Rundle et al. 2000, Rocha et al. 2005).

Contrary to oceans, estuaries are expected to produce strong genetic substructuring due to the high degree of abiotic and biotic heterogeneity. Physiological barriers and spatial isolation produce substantial limitations to gene flow among estuarine populations (Bilton et al. 2002, Kelly et al. 2006). Indeed, a strong genetic structure has been observed in low dispersal organisms like polychaetes (Virgilio & Abiatti 2004) and amphipods (Kelly et al. 2006). In the cases where species with substantial dispersal capacities were involved, the observed genetic structure was linked to estuarine circulation (Perrin et al. 2004), to retention of individuals (Caudill & Bucklin 2004) or even to selection (Lee 2000). In view of their high environmental heterogeneity, estuaries might be hot spots for diversity (Kelly et al. 2006).

The heterogeneity of marine environments is further illustrated in the high amount of cryptic species that have been observed in all major marine taxa (reviewed in Knowlton 1993). The advance in molecular techniques and consequently the increase in population genetic studies have revealed substantial 'intraspecific' genetic diversity in a broad variety of marine species (e.g. Rocha-Olivares et al. 2001, Jolly et al. 2005, Mathews 2006, Remerie et al. 2006a, Suatoni et al. 2006, Hart et al. 2006). Interestingly, these highly divergent molecular lineages are nearly always accompanied by very low genetic variation within lineages. This suggests that the molecular lineages have distinct gene pools and consequently, that they are not interbreeding.

### A FEW WORDS ABOUT SPECIES COMPLEXES

*Cryptic (or sibling) species* are species that are indistinguishable based on morphological characteristics but that have substantial genetic differences between them. All cryptic species are commonly designated as a *species complex* within the morphologically defined (super) species. Although marine speciation was initially thought of as a merely allopatric process occurring over long time spans (Palumbi 1994), the large amount of recently diverged sister taxa, quite often accompanied by a sympatric distribution, suggests that marine speciation is rather quick and may occur at small spatial scales (Rocha-Olivares et al. 2001, Howell et al. 2004)<sup>6</sup>.

**One might wonder whether it really matters to know about species that are morphologically indistinguishable...** An adequate knowledge of marine biodiversity is, however, a basic requirement for conservation strategies with long term effectiveness (Cognetti & Maltagliati 2004). *Biological diversity* refers to all of nature's variation and is situated at different levels of organismal organisation: ecosystem, species and even genes (Anonymous, 1992). Quantifying this global biological diversity is important because diversity may affect the functioning of ecosystems. It is now well-established, mainly on the basis of studies in terrestrial environments, that changes in species composition, distribution and abundance can strongly influence various aspects of ecosystem functioning (Loreau et al. 2001; Naeem & Wright 2003). The nature of the relationships between species diversity and ecosystem functioning remain, however, controversial (e.g. Tilman 1996, Emmerson et al. 2001, De Mesel et al. 2006). A correct interpretation of such relationship requires information on the effects that individual populations have on ecosystem functions (Johnson et al. 1996, Wall & Moore 1999), and requires well - established diversity 'units'. This unit is generally situated at the species level. Obviously, the discovery of a large amount of cryptic diversity is important for a correct quantification of the relationship between species diversity and ecosystem functioning. Depending on the question, other diversity units have been generated. Populations with ecological and genetic variation of adaptive significance (ESUs, evolutionary significant units) may be particularly relevant for conservation strategies (e.g. Crandall et al. 2000). For taxa with a large amount of unknown diversity, like meiofauna organisms, molecular operational taxonomic units (MOTU's) based on

---

<sup>6</sup> See Introduction Chapter 9

genetic similarity and molecular phylogenies have been proposed and tested (Floyd et al. 2002, Blaxter et al. 2005).

*NEMATODES: WHAT WE KNOW AND DON'T KNOW...*

Nematodes are one of the most successful metazoan phyla, especially with respect to their abundances, their ubiquitous distribution and high functional and taxonomical diversity (Heip et al. 1985, Lamshead 2004). Parasitic species of agricultural crops (e.g. *Meloidogyne* species), cattle (e.g. *Ascaris*) and men (e.g. *Necator*) have received much attention due to their economical and health implications. The majority of the Nematoda are, however, primarily free-living in sediments of marine, terrestrial and freshwater environments. This ubiquitous distribution reflects a great physiological tolerance to different environmental conditions and correlates well with the distribution of resources (Lamshead 2004). Marine nematode densities are highest in muddy, organic rich coastal sediments where they reach up to  $10^7$  individuals  $m^{-2}$  (Boucher & Lamshead 1995). Estuarine sediments typically harbour between  $10^5$  -  $10^7$  individuals  $m^{-2}$  (Heip et al. 1985) and tend to be relatively less diverse compared to shallow intertidal and coastal sediments. Next to these high densities, nematode diversity in marine sediments quickly reaches more than 10 species  $cm^{-2}$  (Heip et al. 1985).

Considering these high densities and diversity, **what role may nematode communities play in the ecosystem?** Nematodes were long thought to play an important role in benthic energy fluxes (Kuipers et al. 1981, Coull 1999), but tracer studies now indicate that C-flows through nematodes are very limited (Middelburg et al. 2000, van Oevelen et al. 2006, Urban-Malinga & Moens 2006). In addition, they may regulate the bacterial community through mineralisation of (limiting) nutrients (Anderson et al. 1983, Standing et al. 2006), grazing (Johannes 1965) and the secretion of mucus trails (Riemann & Helmke 2002, Moens et al. 2005). Recently, laboratory experiments have shown that species-specific interactions, like food preferences, alter the bacterial composition (De Mesel et al. 2004). The movements of nematodes may also enhance the diffusion of nutrients and oxygen in the sediment (Cullen 1973, Aller & Aller 1992). In marine environments, it has been shown that nematodes enhance the decomposition of organic material (Alkemade et al. 1992), although such enhancement is not a general phenomenon (De Mesel et al. 2003).

Instead, the effects of nematodes on decomposition rates of organic material in the marine environment are largely idiosyncratic (De Mesel et al. 2006).

Apart from questions related to their biology and function, **what questions have nematodes left us?** Dispersal capacities of marine nematodes are thought to be low due to the absence of pelagic larvae or other dispersive stages. Marine nematodes move around in the sediment and even swim in the water column (Gerlach 1977, Wetzel et al. 2002) but active dispersal should be limited due to their small body size (< 1 mm). This contradicts the broad-scale distribution of many nematode species, some of which seem to have a cosmopolitan distribution. How can species with limited dispersal capacities have such a wide distribution range? Passive dispersal mediated by water currents (Fegley 1987), waterfowl or drifting algae may transport nematodes over considerable distances. Nematodes living in the sediment of intertidal environments will be more frequently suspended in the watercolumn than their subtidal counterparts. Likewise, epiphytic species may be more prone to suspension than sediment dwelling organisms. Unfortunately, **the dispersal capacity of marine nematodes remains highly speculative because unambiguous data is currently lacking.**

Interestingly, many congeneric species coexist and are morphologically very similar (Tietjen & Lee 1977, Jensen 1987). This evidently has strong implications for some basic ecological principles. How can species with seemingly similar ecological functions and niches co-occur when they are expected to exclude each other from the habitat through competitive exclusion? The coexistence of similar species within a trophic group may be explained through niche segregation or through stochastic factors introducing niche gaps which may then be colonized by other species (Ekschmitt & Griffiths 1998). The latter scenario implies the occurrence of a mosaic of non-equilibrium patches (Lamshead 2004). **Insights in the dynamics of nematode populations is, however, lacking.** Furthermore, a correct assessment of either hypothesis can only be tested if clear, straightforward diversity units are used. These units are typically situated at the species level, but within free-living nematodes, species identification is not at all straightforward.

Nematodes have a highly conserved body plan, basically consisting of an internal gut and an external body cylinder. This is paradoxical considering the enormous species diversity within the phylum. Many taxonomic studies have, however, highlighted very fine morphological distinctions, such as cuticle pattern or

the presence/absence of setae that are situated at scales beyond the resolution of light microscopy (Blaxter et al. 2005, De Ley et al. 2005). To make matters even more complicated, many nematode species show considerable morphological plasticity across geographical areas (e.g. *Halomonhystera*) or can only be identified if both males and females are available. The high species diversity of the phylum results in a large taxonomic deficit and many species remain to be described (Blaxter et al. 2005). **Species identification therefore requires adequate expertise and remains highly problematic.**

Problematic taxa could benefit from a novel approach aiming to speed up and ameliorate the identification process. An appealing way to describe biological diversity may lay in a DNA barcoding system that overcomes many of the practical limitations of morphology-based identification systems (Hebert et al. 2003 a, b). The use of a DNA barcoding approach for meiofauna identification (Markmann & Tautz 2005), and for nematodes in particular, is currently being explored (Blaxter 2004, Blaxter et al. 2005, De Ley et al. 2005, Bhadury et al. 2006).

#### THE RESEARCH MODEL

The present study focuses on two free-living, cosmopolitan nematode species, *Rhabditis (Pellioiditis) marina* (Bastian 1865) and *Halomonhystera disjuncta* (Bastian 1865). Both species are members of different orders within the Chromadorea, the Rhabditida and Monhysterida, respectively (De Ley & Blaxter 2003, Table 1.1). *H. disjuncta* is formerly known as *Geomonhystera disjuncta*, which was only very recently assigned to a new genus, *Halomonhystera*, by Andr assy (2006). *Halomonhystera* is distinct from *Geomonhystera* Andr assy, 1981 by its minute labial sensory organs, scarce and minute cephalic setae, a short oesophagus and rectum, and a gubernaculum with caudal process. Most conspicuous, the vulva is situated at least 75 % of total body length (Andr assy 2006). For *R. (P.) marina*, the genus *Pellioiditis* was recently designated a subgenus of the genus *Rhabditis* by Sudhaus & Fitch (2001)<sup>7</sup>.

---

<sup>7</sup> In the unpublished Chapters (5, 6, 9 and 10) we used the most recent nomenclature, i.e. *Rhabditis (Pellioiditis) marina* and *Halomonhystera disjuncta*. The other chapters have been published using the older nomenclature *Pellioiditis marina* and *Geomonhystera disjuncta*.



They occur on living algal stands, but are especially abundant and dominant on decomposing macroalgae and on other organic material deposited along the high water mark in coasts and estuaries. Such piles of rotting litter are patchily distributed and highly unstable, due to pronounced fluctuations in abiotic factors and physical disturbances inherent to the intertidal environment. The species inhabiting such discontinuous and transient habitats are strong colonizers and generally have a short generation time and a high reproductive output.

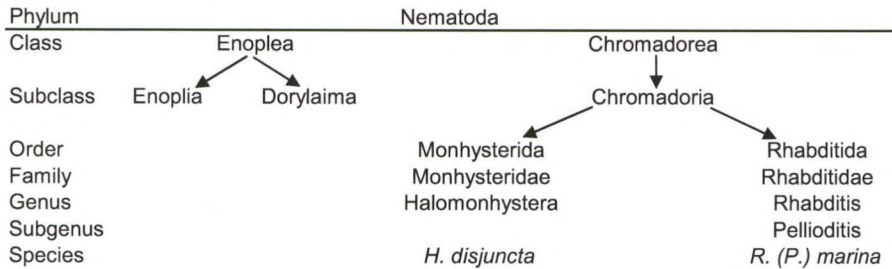

**Table 1.1:** Taxonomic position of *Halomonhystera disjuncta* and *Rhabditis (Pellioiditis) marina*. The classification to family level is based on De Ley & Blaxter (2003). The classification within the Rhabditidae is based on Sudhaus & Fitch (2001) and within the Monhysteridae on Andr assy (2006).

*R. (P.) marina* and *H. disjuncta* are typical r-strategists<sup>8</sup> and occur sympatrically on macroalgal deposits in the North Sea and adjacent estuaries (Moens & Vincx 1997). The meiofauna communities of this area have been particularly well investigated (Vincx 1990, Moens 1999). *Fucus* species attached to dikes and stones are among the predominant macroalgae in this area. They may become detached during storms and/or tides and subsequently wash ashore during high tide. Although *R. (P.) marina* and *H. disjuncta* show remarkable similarities in their biological characteristics, the former typically colonizes algal patches more rapidly than *H. disjuncta* (because of its much shorter generation time) and is more restricted to algal habitat, whereas *H. disjuncta* is more of a generalist occurring on different types of organic debris and even in sediment<sup>9</sup>.

The genetic patterns in both species were investigated by screening genetic variation in the mitochondrial cytochrome oxidase c subunit 1 (COI) gene. We used the Single Strand Conformation Polymorphism (SSCP) method and direct nucleotide

<sup>8</sup> See Introduction Chapters 2 and 3 for *R. (P.) marina* and Chapter 4 for *H. disjuncta*

<sup>9</sup> See Introduction Chapter 4

sequencing. The underlying assumption of most population genetic studies is that the observed structure is stable over time<sup>10</sup>. Because of the highly fluctuating environment and transient habitat, the population genetic structure of both species was investigated in several seasons. Highly divergent mitochondrial lineages were evaluated by complementary nucleotide sequencing of two nuclear fragments, the internal transcribed spacer region (ITS1-5.8S-ITS2) situated between the small (18S) and large (28S) subunit genes of the ribosome, and the expansion segments (D2-D3) situated at the 5' end of the large subunit gene (28S).

#### AIMS AND OUTLINE OF THE THESIS

The principal aim of this thesis was to investigate the patterns of population genetic structure in two free-living nematodes. We obtained information on 1) dispersal capacities and population dynamics of 'epiphytic' nematodes, 2) the contemporary processes responsible for the observed genetic patterns, and 3) the taxonomic status of deeply diverged genetic lineages within morphologically defined species. At the same time, the large COI dataset may assist to assess its usefulness for nematode species identification. Finally, the effects of historical processes on present day genetic patterns and on speciation in marine nematodes were investigated. The structure of the thesis consists of three main parts.

The first part focuses on **the patterns of population genetic structure of two free-living nematode species** in the Belgian part of the North Sea and its adjacent estuaries in The Netherlands. The relatively small geographical study area (< 100 km) was chosen mainly to exclude the differential impact of historical events, while the comparison between two sympatrically distributed species at the same time eliminated effects of differences in geography. The comparison between *R. (P.) marina* and *H. disjuncta* thus contributes to our understanding of the effects of life-history (generation time, habitat preferences) on the population genetic structure of free-living nematodes. Most importantly, the population genetic structure in both species was studied over several seasons, which enabled us to look at the temporal stability of the observed genetic patterns. In [Chapter 2](#), the population genetic structure of *R. (P.) marina* is described using two Belgian coastal populations, five estuarine locations

---

<sup>10</sup> See Introduction Chapter 3

(Westerschelde), one coastal lagoon location (Oosterschelde) and one location in a geographically isolated saline lake (Lake Grevelingen). In this way, we were able to investigate the effects of 1) connectivity, 2) environmental gradients (salinity, pollution) and 3) geographic distance on the genetic structure of *R. (P.) marina*. Unexpectedly high levels of genetic divergence led to the designation of at least four cryptic species within *R. (P.) marina*. In [Chapter 3](#), the spatiotemporal dynamics of the *R. (P.) marina* species complex was investigated in four consecutive seasons. This chapter also contributes to the knowledge on differential effects of coasts, estuaries and lakes on the population genetic structure of *R. (P.) marina*. In [Chapter 4](#), the population genetic structure of *H. disjuncta* is described in two seasons in Belgium and The Netherlands and the spatiotemporal patterns are compared to those of *R. (P.) marina*: are the observed patterns species-specific or can they be representative for other free-living marine nematodes?

While the first part focused on patterns in population genetic structure, the second part of this thesis uses a combination of molecular, morphological and, to a lesser extent, biological data to infer **the taxonomic status of the deeply diverged mitochondrial lineages** discovered in *R. (P.) marina* and *H. disjuncta* (see Chapters 2, 3 and 4). This part comprises [Chapter 5](#), in which an integrative approach is used to delimit species boundaries in the *R. (P.) marina* and *H. disjuncta* species complexes and in which the performances of morphological and genetic data in delineating species/taxonomic units are compared, and [Chapter 6](#), which deals with the taxonomic position of three additional divergent haplotype groups in *R. (P.) marina*. Here, we used three molecular markers (the mitochondrial COI-gene and two nuclear genes, the ITS region and D2-D3 segments) and morphological data which was further investigated for geographical variation.

In the last part of this thesis, focus is on some of **the processes that are affecting the population genetic structure** of the *R. (P.) marina* species complex. **Contemporary genetic processes** were investigated in two types of experiments. In [Chapter 7](#), we performed a field experiment in the Westerschelde to document colonisation patterns of empty algal patches by nematodes. The experiment comprised two experimental plots, one amidst a permanent population of *R. (P.) marina* and a second plot situated more than 100 m away from any source population. We expected 1) a quicker colonisation, 2) less genetic variation and 3) a higher similarity among patches situated amidst the permanent source population. This experiment nicely

documented the theory on founder effects, genetic bottlenecks and monopolisation of resources. Chapter 8 describes the influences of sublethal stressors on the genetic composition of *R. (P.) marina* populations under a variable range of salinities. It is generally assumed that abiotic stressors like pollution may reduce the genetic variation within populations due to genetic bottlenecks and genetic drift. We followed the population development of *R. (P.) marina* under nine Cd/salinity combinations and expected a reduced offspring production under the most stressful conditions. We investigated whether such a demographic bottleneck was accompanied by a genetic bottleneck by screening COI variation in three generations. The effects of **historical processes**, like climate changes and vicariance, on the population genetic structure of *R. (P.) marina* were studied in Chapter 9. *R. (P.) marina* was sampled throughout its European distribution range and in several populations along the NW-Atlantic, South Africa and Australia. We expected to find additional cryptic diversity and to unravel micro- and macro-evolutionary processes.

We conclude with a general discussion in Chapter 10, in which we take the opportunity to address some key questions on dispersal, population dynamics, species coexistence and species identification in meiofauna organisms.

118953

---

**CHAPTER II**

**MITOCHONDRIAL DNA VARIATION AND CRYPTIC  
SPECIATION WITHIN THE FREE - LIVING MARINE NEMATODE**

*PELLIODITIS MARINA*

---

Published as:

Derycke S, Remerie T, Vierstraete A, Backeljau T, Vanfleteren J, Vincx M, Moens T (2005) Mitochondrial DNA variation and cryptic speciation within the free-living marine nematode *Pellioditis marina*. **Mar Ecol Progr Ser** 300: 91-103.

### ABSTRACT

An inverse correlation between dispersal ability and genetic differentiation among populations of a species is frequently observed in the marine environment. We investigated the population genetic structure of the free-living marine nematode *Pellioiditis marina*. 426 bp of the mitochondrial COI gene was surveyed on a geographical scale of approximately 100 km during spring 2003. Nematodes were collected in two coastal locations in Belgium, and in two estuaries and a saltwater lake (Lake Grevelingen) in The Netherlands. Molecular variation was assessed with the Single – Strand Conformation Polymorphism (SSCP) method.

In total, 32 haplotypes were observed, and sequence divergence among 452 individuals ranged from 0.2 – 10.6 %. Four distinct mitochondrial lineages were discovered, with low divergences within the lineages (0.2 – 1.6 %) and high divergences between the lineages (5.1 – 10.6 %). The nuclear ribosomal ITS-region showed concordant phylogenetic patterns, suggesting that nematode species diversity may be considerably underestimated.

AMOVA indicated a strong genetic differentiation among populations. The Lake Grevelingen population was clearly differentiated from all other populations, but genetic structuring was also significant within the Westerschelde and was correlated with gradients in salinity and pollution. The observed population genetic structure is in accordance with the limited active dispersal capacity of *P. marina*, but is at variance with its significant potential for passive dispersal. We therefore suggest that autecological characteristics, including short generation time, high colonisation potential and local adaptation may be at the basis of this nematode's population genetic structure.

## INTRODUCTION

Many marine populations are thought to be demographically open because of long-distance larval dispersal (Caley et al. 1996). During the last decade, however, unexpectedly high levels of genetic differentiation have been reported for marine organisms with supposedly high dispersal capabilities (e.g. Taylor & Hellberg 2003, Caudill & Bucklin 2004, Ovenden et al. 2004), illustrating that straightforward predictions on the relationship between dispersal ability and genetic differentiation remain problematic. Fewer studies have focused on species with low(er) dispersal abilities (Schizas 1999, 2002, Kirkendale & Meyer 2004), where population genetic structuring is expected to be higher (Avise et al. 1987, Palumbi 1994). Factors influencing gene flow in marine species are roughly divided into physical (e.g. ocean currents, habitat characteristics) and biological (e.g. life-history, predation, larval and adult behaviour) categories (Hohenlohe 2004). These characteristics limit the dispersal abilities of planktonic larvae, and render marine environments less open than previously thought. Furthermore, the issue of spatial scale may further complicate the discussion about open vs closed marine populations (Cowen et al. 2000, Camus & Lima 2002).

In addition, population genetic surveys have also revealed that many marine 'species' are in fact species complexes involving morphologically cryptic taxa (Knowlton 1993, Todaro et al. 1996, Matthews et al. 2002, Bond & Sierwald 2002, McGovern & Hellberg 2003). Such complexes are especially prominent in small invertebrates with few taxonomically diagnostic characters (Rocha – Olivares et al. 2001). This taxonomic confusion evidently complicates the interpretation of distribution and dispersal patterns in the marine environment (Kirkendale & Meyer 2004).

In this study, we investigate the population genetic structure of the free-living marine nematode *Pellioiditis marina* Andrassy 1983 (syn. *Rhabditis marina* Bastian (1865))<sup>11</sup> over a fairly small geographic area. Nematodes are the most abundant metazoans on earth, and they are highly speciose at very small (< m<sup>2</sup>) to global scales, with estimates of total species numbers (including zoo- and phytoparasitic species) ranging from 10<sup>5</sup> (Coomans 2000) up to 10<sup>8</sup> (Lamshead 1993). Their omnipresence

---

<sup>11</sup> But see General introduction, p 9. *Pellioiditis* is at present considered to be a subgenus of *Rhabditis*

and high diversity combined with functional variability render them an interesting model group to test concepts about the link between structural and functional biodiversity (Coomans 2002, De Mesel et al. 2003).

Most marine nematodes are endobenthic organisms with very limited active dispersal capacities. Passive (through erosion) and active (Wetzel *et al.* 2002) emergence into the water column do, however, occur, and passive dispersal through water currents, waterfowl or ballast water is plausible but hitherto poorly studied. *Pellioiditis marina* typically frequents standing and decomposing macroalgae in the littoral zone of coastal environments (Moens & Vincx 2000b) and may therefore be more prone to passive resuspension and transport (e.g. through “rafting”) than typically endobenthic nematodes. Its high reproductive capacity (up to 600 eggs per female under optimal conditions (Vranken & Heip 1983)) and short generation time (less than three days under optimal conditions (Vranken & Heip 1983, Moens & Vincx 2000a)) render this species a strong colonizer capable of establishing viable populations from one or a few gravid females. In view of these features, we expected some capacity for passive dispersal and gene flow, at least over limited geographical distances.

Several marine nematode species have wide to nearly cosmopolitan distributions. This also holds for *Pellioiditis marina*, which has been reported from coastal environments in Europe, along the Mediterranean Sea, on both sides of the Atlantic Ocean (Inglis & Coles 1961), Vancouver Island (Canada) (Sudhaus & Nirmrich 1989), New Zealand, North Africa, Australia, South America (Sudhaus 1974), and from both the Antarctic and Arctic archipelago (Moens unpublished). Such a wide geographical distribution is at variance with the alleged limited dispersal capacities of nematodes. However, *P. marina* shows substantial morphological (Inglis & Coles 1961, Sudhaus 1974), reproductive (oviparous vs ovoviviparous) and physiological variation. As an example, some populations thrive well at temperatures which are lethal to other populations (Moens & Vincx 2000a). While this in part may reflect local adaptation and phenotypic plasticity, it may also relate to differentiation among cryptic taxa as a result of vicariance events. Hence, since marine nematode taxonomy heavily relies on morphological criteria, there is an urgent need for information on the population genetic structure and cryptic variation within such morphologically defined species in order to better understand their current distribution and dispersal patterns.



Against this background, we used Single Strand Conformation Polymorphisms (SSCP) (Orita et al. 1989, Sunnucks et al. 2000) and DNA sequencing to screen mitochondrial COI nucleotide sequence variation of *P. marina* on a small and largely continuous geographical scale (ca. 100 km) along the Belgian coast and in the Scheldt Estuary (The Netherlands). This area comprises various suitable habitat types for *P. marina*, as well as several locations with different degrees of connectivity. This sampling design enabled us to test the influence of (1) different habitats (estuaries, lake and coast), (2) environmental gradients (salinity, pollution) and (3) geographic distance on the population genetic structure of a free-living nematode.

## MATERIAL AND METHODS

### SAMPLE LOCATIONS

Individuals of *Pellioiditis marina* were collected from 10 locations in Belgium, The Netherlands and England during April-June 2003 (Fig. 2.1). In Belgium, two coastal locations were sampled (Nieuwpoort: Ni; Blankenberge: Bl), representing true marine habitats with a coarse sandy sediment and direct impact of the sea. In The Netherlands, seven localities were sampled in two arms of the Scheldt Estuary (Westerschelde, Oosterschelde: Os) and in Lake Grevelingen (Gr). The Westerschelde is highly polluted, as it is a major drain for industrial and domestic wastes (De Wolf et al. 2004). Salinity varies between 12 and 35 in the upperpart of the estuary comprising our sample locations. The Oosterschelde estuary is relatively clean and shows little to no variation in salinity (33-35 psu). Lake Grevelingen also has a fairly constant salinity (32 psu) but differs from the Oosterschelde by being cut off from the sea and the lack of tidal currents. Yet, both Lake Grevelingen and the Oosterschelde were transformed into their current basin like shape by man during the 60-70's. Both environments are thus very young. Finally, in England one population was sampled in Plymouth, in the mouth of the River Plym (salinity of 32), in order to compare our small-scale patterns with larger-scale differentiation.

The following entities can thus be identified in our sampling design: (1) locations with no apparent physical barrier between them (two Belgian coastal stations and five locations within the Westerschelde); (2) two nearby but recently isolated locations by both natural and man-made barriers (Oosterschelde and Lake

Grevelingen); (3) locations within the Westerschelde (40 km) along a salinity and pollution gradient and (4) samples from the more distant location of Plymouth (southwest England) under influence of Atlantic currents.

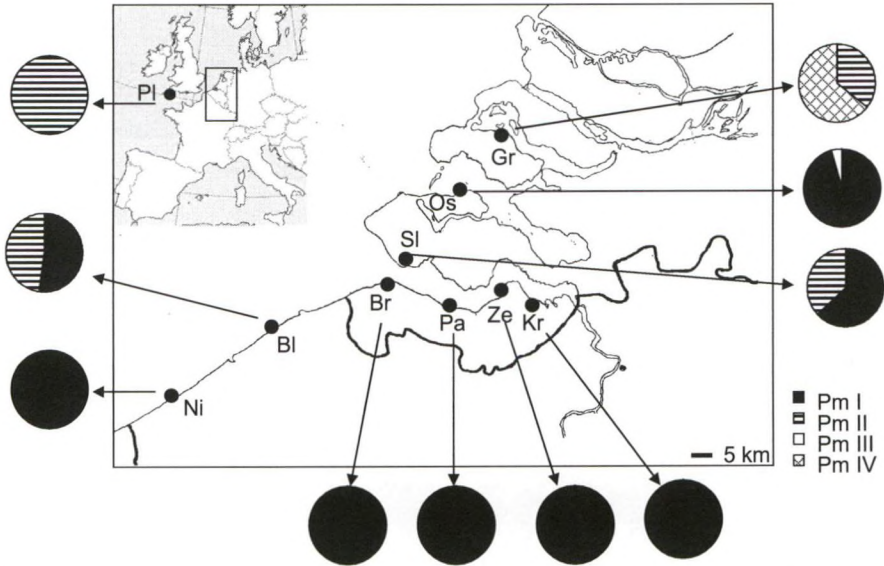

Fig. 2.1. Location of the sampled populations and distribution of the four lineages PmI, PmII, PmIII and PmIV. (Ni = Nieuwpoort (51° 9' N, 2° 43' E); Bl = Blankenberge (51° 19' N, 3° 8' E); Br = Breskens (51° 24' N, 3° 33' E); Pa = Paulina (51° 21' N, 3° 49' E); Ze = Zeedorp (51° 24' N, 3° 58' E); Kr = Kruispolderhaven (51° 22' N, 4° 3' E); Sl = Sloehaven (51° 27' N, 3° 36' E); Os = Oosterschelde Estuary (51° 36' N, 3° 50' E); Gr = Grevelingen lake (51° 44' N, 3° 57' E); Pl = Plymouth (50° 22' N, 4° 9' E).

#### SAMPLE COLLECTION AND PROCESSING

Approximately 50 individuals from each location were processed, except from Plymouth, where only 31 individuals were analysed. Fragments of *Fucus* sp. (*Ulva* sp. and *Sargassum* sp. in Lake Grevelingen) were randomly collected and incubated on agar slants (Moens & Vincx 1998). Nematodes were subsequently allowed to colonize the agar for about two days, which is less than one generation time under the incubation conditions used here (Moens & Vincx 2000a). *Pellioditis marina* was then identified under a dissecting scope using diagnostic morphological characters (Inglis & Coles 1961) and handpicked from the agar with a fine needle. All individuals were transferred through sterile water and photographed digitally as a morphological reference. All worms were stored individually in 70 – 95 % acetone until processed.

Two individuals of the congener *Pellioiditis ehrenbaumi* (syn. *Rhabditis nidrosiensis* (Sudhaus 1974), where *Rhabditis* and *Pellioiditis* are subgenera of the genus *Rhabditis* (Sudhaus & Fitch 2001)) from stranded macroalgae in the Oosterschelde were also isolated and preserved on acetone.

#### DNA EXTRACTION AND PCR AMPLIFICATION

Prior to DNA extraction, the nematodes were transferred into sterile distilled water for approximately 30 min to remove traces of acetone. Individual nematodes were then transferred to 20  $\mu$ l Lysis Buffer (50 mM KCl, 10 mM Tris pH 8.3, 2.5 mM MgCl<sub>2</sub>, 0.45 % NP40, 0.45 % Tween20), cut in pieces with a razor and frozen for 10 min at -20 °C. Proteinase K (60  $\mu$ g ml<sup>-1</sup>) was added and samples were incubated 1 h at 65 °C, followed by 10 min at 95 °C. Finally, the DNA-samples were centrifuged for 1 min at maximum speed (13200 rpm). One  $\mu$ l of extracted DNA was used as template for polymerase chain reactions (PCR)<sup>12</sup>.

A portion of the mitochondrial cytochrome oxidase c subunit 1 (COI) gene was amplified with primers JB3 (5'-TTTTTTGGGCATCCTGAGGTTTAT-3') and JB4.5 (5'- TAAAGAAAGAACATAATGAAAATG-3') (Hu et al. 2002). Standard PCR- amplifications were conducted in 25  $\mu$ l volumes for 35 cycles, each consisting of a 30 s denaturation at 94 °C, 30 s annealing at 54 °C, and 30 s extension at 72 °C, with an initial denaturation step of 5 min at 94 °C and a final extension step of 5 min at 72 °C. Because DNA amplification of nematodes from lake Grevelingen consistently failed with these primers, we constructed a new reverse primer (JB5; 5'-AGCACCTAAACTTAAAACATAATGAAAATG-3') based on rhabditid nematode sequences from GenBank. Five  $\mu$ l of each PCR-product was loaded on a 1 % agarose gel to check the size of the amplified product.

We additionally analysed the nuclear ribosomal internal transcribed spacer region (ITS) of several mitochondrial haplotypes. The primers from Vrain et al. (1992) were modified: VRAIN 2F (5'-CTTTGTACACACCGCCCGTCGCT-3') and VRAIN 2R (5'- TTTCACTCGCCGTTACTAAGGGAATC-3'); these primers anneal in the conserved 28S and 18S region of the ribosomal DNA and amplify a product of approximately 900 bp (ITS-1, 5.8S and ITS-2). PCR-conditions were similar to those

<sup>12</sup> The remaining amount of DNA was stored at -80°C. In this way, the same DNA-samples could be used for the amplification of multiple markers.

for amplification of the COI fragment, except for the final extension step, which lasted 10 min instead of 5.

### *SINGLE STRAND CONFORMATION POLYMORPHISMS (SSCP)*

For SSCP-analysis, 2.5  $\mu\text{l}$  of PCR-product was mixed with 5.5  $\mu\text{l}$  loading dye (5 % EDTA, 95 % formamide, 0.05 % bromophenol blue), denaturated for 5 min at 95 °C and put immediately on ice until loading on a non-denaturing polyacrylamide gel (0.5 mm thick, 2 % crosslinking and 5 % glycerol). For these horizontal gels, electrode strips were made with Tris/Hac (0.45 M) and Tris/Tricine (0.8 M) buffers. The conditions for electrophoresis (15 W, 4 h at 5 °C) were standardized for optimal resolution of bands, allowing the detection of single base differences for the 426 bp COI fragment. SSCP has a capacity to detect 75 – 95 % of the point mutations using fragments of 200 bp or less (Zhu & Gasser 1998), although the same authors showed that sequence heterogeneity can also be displayed in fragments of 440-550 bp. A single point mutation in a 530 bp fragment of the ITS-2 sequence of *Toxocara cati* was also detected by this method (Zhu et al. 1998). After electrophoresis, haplotypes were visualized with a DNA silver staining kit (Amersham Biosciences) and scored by their relative mobility.

### *DNA SEQUENCING*

All samples with different SSCP patterns were sequenced with both the forward and reverse primers as described above. To ensure that band mobilities were consistent with actual sequence variability, we additionally sequenced 10 % of the samples from every location. Our SSCP conditions proved capable of distinguishing all haplotypes, except for one very rare haplotype ( $n = 2$ , in Sloehaven (Sl)) which was omitted from the dataset. Ribosomal ITS fragments were not analysed with SSCP but sequenced directly.

Sequencing was performed using a Perkin Elmer ABI Prism 377 automated DNA sequencer. The PCR product was purified with shrimp alkaline phosphatase (1 U  $\mu\text{l}^{-1}$ , Amersham E70092Y) and exonuclease I (20 U  $\mu\text{l}^{-1}$ , Epicentre Technologies X40505K) and cycle-sequenced using the ABI Prism BigDye V 2.0 Terminator Cycle Sequencing kit.

## DATA ANALYSIS

### Genetic diversity

Standard measures of genetic variation within populations, such as nucleotide diversity ( $\pi$ ) (Nei 1987) and gene diversity ( $h$ ) (Tajima 1983, Nei 1987) were calculated using ARLEQUIN v.2.0. (Schneider et al. 2000). Sequences were aligned with ClustalV 1.64b (Higgins 1991) and were trimmed for further phylogenetic analysis in PAUP\* 4.0 beta 10 (Swofford 1998). MODELTEST 3.06 (Posada & Crandall 1998) was used to determine that GTR+I+G model was the most suitable for maximum likelihood analyses of our mitochondrial and nuclear data. The corresponding sequences of the closely related, marine/estuarine species *Pellioditis ehrenbaumi* were used for outgroup comparison (Accession number AJ867056 for COI and AJ867073 for ITS). Maximum parsimony (MP) and neighbour joining (NJ) trees were inferred with 1000 bootstrap replicates and 10000 rearrangements, while Maximum Likelihood (ML) trees inferred from 100 bootstrap replicates and 500 rearrangements. Trees were obtained via stepwise addition and a tree-bisection-reconnection branch swapping algorithm was used. Sequences were added randomly in 10 replicate trials, with one tree held at each step. To explore the intraspecific relationships between the observed haplotypes, a minimum spanning network was constructed with ARLEQUIN v.2.0. and drawn by hand in Microsoft PowerPoint. Ambiguities in the network were resolved following the criteria suggested by Crandall & Templeton (1993).

### Population genetic structure

The genetic structure of *Pellioditis marina* was analysed with ARLEQUIN's AMOVA (Analysis of MOlecular VARIance). This procedure calculates the molecular variance and  $\phi$ -statistics among and within populations, and the significance of the variance components is tested by permuting haplotypes among populations (Excoffier et al. 1992). AMOVA was performed for all sequences combined and, where possible, for every clade separately.

Genetic distances, which are a measure for the variability within versus between populations, between different populations were also calculated in ARLEQUIN, using the Tamura and Nei correction for different transversion and

transition rates. This model also distinguishes between different transition rates among purines and pyrimidines (Tamura & Nei 1993). Table-wide significance levels of the p-values obtained with 10000 permutations were corrected for multiple tests according to the sequential Bonferonni method (Rice 1989). To visualize the genetic distances between the different populations, a multidimensional scaling (MDS) plot was drawn using the program Primer 5.2.9 (Clarke & Gorley 2001).

To test the isolation-by-distance model (IBD, Slatkin 1993), geographic and genetic distances were compared using a Manteltest as implemented in ARLEQUIN. The geographic distance between populations was measured as the shortest continuous water surface distance. The number of permutations was set to 1000. The strength of the IBD relationship was determined with reduced major axis (RMA) regression as implemented in the program IBD 1.5 (Bohonak 2002).

RESULTS

INTRASPECIFIC VARIATION OF COI

In total, 452 individuals of *Pellioiditis marina* were analysed for sequence variation in a 426 bp amplicon of the mitochondrial COI gene, yielding 32 haplotypes (Table 2.1). No insertions or deletions occurred within the trimmed fragment (393 bp long), and a total of 73 variable sites (18.58 %) were observed (Appendix 2.1), 51 of which were parsimony informative, involving 44 synonymous substitutions and seven replacement sites. Pairwise divergences between the COI sequences ranged from 0.23 % (1 base substitutions) to 9.6 % (41 substitutions), most of them being third-base transversions. All sequences are available in GenBank under Accession numbers AJ867447 – AJ867478.

	A	C	D	E	F	H	I	J	K	L	M	N	O	P	R	S	T	U	V	W	G1	G2	G3	R1	R2	R3	R4	R5	O1	O2	S1	S2	n	h	$\pi$	
Br	17	-	16	-	8	5	-	1	-	-	-	2	-	-	-	-	-	-	-	-	-	-	-	-	-	-	-	-	-	-	-	-	-	49	0.7491	0.0072
Pa	15	-	13	3	1	2	3	1	-	-	-	8	-	-	-	-	-	3	-	-	-	-	-	-	-	-	-	-	-	-	-	-	-	49	0.8121	0.0086
Ze	16	4	17	-	1	3	4	2	2	-	-	-	-	-	-	-	-	-	-	-	-	-	-	-	-	-	-	-	-	-	-	-	49	0.7679	0.0075	
Kr	33	-	1	-	9	-	-	-	-	-	-	1	-	-	-	-	-	-	-	-	-	-	-	-	-	-	-	-	-	-	-	-	44	0.4038	0.0034	
Si	6	2	5	-	1	-	12	-	1	-	-	15	-	1	1	-	1	1	-	-	-	-	-	-	-	-	-	-	-	-	-	-	46	0.8097	0.1807	
Os	7	1	22	-	1	1	-	8	-	3	2	-	2	-	-	-	-	-	-	-	-	-	-	-	-	-	-	-	-	-	-	-	47	0.7364	0.0237	
Bl	22	-	-	-	-	1	-	-	-	-	-	-	-	6	7	-	1	-	-	-	-	-	-	-	-	-	-	-	7	-	-	44	0.6956	0.1995		
Ni	6	-	-	-	1	-	-	9	-	-	-	22	-	-	-	-	10	-	-	-	-	-	-	-	-	-	-	-	-	-	-	48	0.7101	0.0038		
Gr	-	-	-	-	-	-	-	-	-	-	-	-	-	-	-	-	-	-	-	7	20	2	3	-	3	4	2	-	4	5	-	45	0.7667	0.1689		
Pl	-	-	-	-	-	-	-	-	-	-	-	-	-	-	-	-	-	-	-	-	-	-	12	8	6	-	-	5	-	31	0.7441	0.0045				
Total	122	7	74	3	21	12	8	33	2	4	2	33	15	2	6	8	11	3	2	1	7	20	2	15	8	6	3	4	2	7	5	4	452			

**Table 2.1:** *Pellioiditis marina*. Distribution of the 32 haplotypes among sampling locations. Haplotype diversity (h) and nucleotide diversity ( $\pi$ ) for every location are indicated; n = number of individuals analysed. For sample location abbreviations see legend Fig. 2.1.

The minimum spanning network revealed 32 haplotypes (Fig. 2.2). For convenience, all locations within the Westerschelde were grouped ('Westerschelde') and the two Belgian coastal locations were pooled ('Coast'). The haplotypes are divided into four distinct groups (PmI, PmII, PmIII and PmIV), with a low number of substitutions within each group (one to seven), and high numbers between groups (23 to 32). PmI and PmII consist of 15 and 13 haplotypes respectively, and are clearly more diverse than the PmIII (only one haplotype) and PmIV (only three haplotypes) groups. Haplotype relations within groups PmI and PmII display a star-like pattern, with the rarer haplotypes showing a higher amount of mutational differences. Furthermore, the haplotypes within group PmI have much higher frequencies than haplotypes from the other groups, haplotypes A, D, J and N being particularly abundant in the Westerschelde and at the Belgian coast. Moreover, the commonest haplotypes, A and D, are present in all locations, except Blankenberge, Plymouth and Lake Grevelingen. Haplotypes belonging to group PmIV are restricted to Lake Grevelingen, G2 being the most abundant. PmII haplotypes are rare in the Westerschelde and Oosterschelde, but comprise all individuals from Plymouth. Haplotypes R1 and O have the highest frequency in this group; four haplotypes are unique to Lake Grevelingen (O1, R4, R5 and S2) and three to Plymouth (R2, R3 and S1). Group PmIII consisted of a single haplotype in very low frequency (M,  $n = 2$ ). This haplotype was only found in the Oosterschelde.

Within the PmI group, 2 replacement sites are observed (represented by the rarely encountered haplotypes U ( $n = 3$ ) and W ( $n = 1$ )). Within the PmII group, six replacement sites are detected, three of which are observed in the rare haplotype V ( $n = 2$ ).

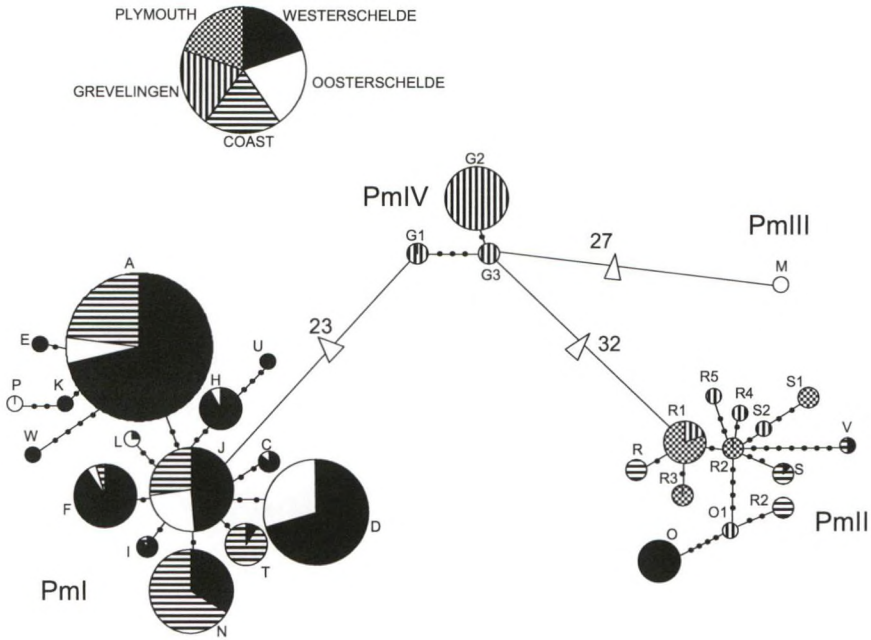

**Fig. 2.2.** *Pellioiditis marina*. Minimum spanning network of the mtDNA COI sequences. The circles are proportional to the frequency of the haplotypes in the total sample. Shared haplotypes among the different hydrodynamic regions are represented by frequency diagrams. Substitutions are represented by black dots, white triangles represent 23 to 32 substitutions.

PHYLOGENETIC ANALYSES

Mitochondrial COI gene

A heuristic search identified 20 most parsimonious trees, which differed from each other only in the position of haplotype V within its clade. One of the MP trees is shown in figure 2.3A. Maximum likelihood and neighbour joining methods gave generally consistent trees. Support for the monophyly of the three major clades (PmI, PmII, PmIV) is strong (> 95 %), while the node that unites haplotype M with those of clades PmI and PmIV lacks good support and was absent in ML and NJ analyses.



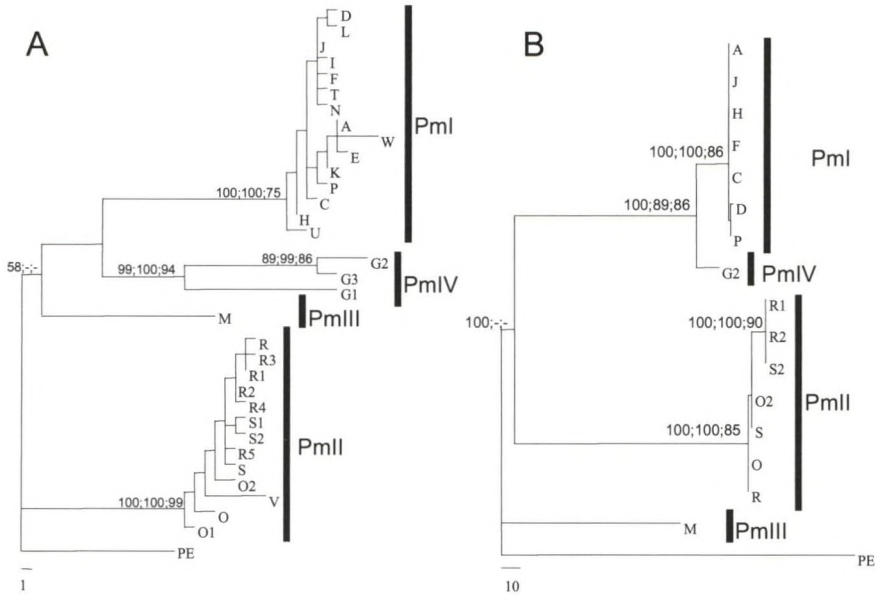

**Fig. 2.3.** *Pellioditis marina*. Maximum parsimony trees for (A) COI and (B) ribosomal ITS sequences. Bootstrap values are based on 1000 replicates and are shown for maximum parsimony, neighbour joining and maximum likelihood respectively. The four clades are indicated by PmI, II, III and IV. The congener *Pellioditis ehrenbaumi* (PE) was used as outgroup species.

### Nuclear rDNA

Because the COI-fragment showed high divergences between and low divergences within clades, we analysed a fragment of the nuclear spacer region. The nuclear genome evolves independently from the mitochondrial genome, and is subject to different evolutionary forces. A concordant pattern between these two markers will therefore provide extra support to the observed mitochondrial subdivision in four clades.

In total, 827 – 859 bp of the ribosomal ITS region were sequenced from 17 individuals (Accession numbers AJ867057 - AJ867072), representing the most abundant mitochondrial haplotypes of each mitochondrial clade. Because the PmIII clade consisted of only one haplotype, both individuals belonging to this clade were processed for the nuclear marker. The alignment (888 sites) of the 17 ITS sequences showed that 240 sites were variable (27 %), 233 of which were parsimony informative. The heuristic search yielded a total of 91 most parsimonious trees, which differed only in the relative positions of individuals within clades (Fig. 2.3B). MP, NJ and ML analyses all separated the individuals into three major clades, which were

supported by strong bootstrap values, and individuals of PmIII were separated from the other three groups showing a basal position in the phylogenetic tree. The length of the amplified region varied because of insertion/deletion differences between the four groups (Appendices 2.2 and 2.3). Within the PmII clade, a clustering of the sequences R1, R2 and S2 was supported by high bootstrap values and differed in four transitions and three transversions from the other PmII sequences. Within clade PmI, all sequences were identical, except for sequence P and D, which differed in one and two transitions, respectively, from the other sequences.

Divergences within the clades ranged from 0 to 0.24 % for clade PmI, and from 0 to 0.81 % for clade PmII. Divergences between the different clades were much higher and are summarized in Table 2.2. When the MP tree was calculated using gaps as a fifth base, no differences in topology were found, except for a better separation of the two groups within the PmII clade.

	PmI	PmII	PmIII	PmIV
PmI	-	8.1 - 10.6 %	7.0 - 7.8 %	5.8 - 7.5 %
PmII	11.0 - 12.0 %	-	8.5 - 10.1 %	8.0 - 9.8 %
PmIII	20.9 - 21.1 %	20.3 - 21.1 %	-	6.8 - 7.3 %
PmIV	3.3 - 3.5 %	10.5 - 11.6 %	20.0 %	-

**Table 2.2.** Divergence range between the four clades. Above diagonal are divergences for the mitochondrial COI fragment, below diagonal for the nuclear ITS region.

INTERSPECIFIC VARIATION AND GEOGRAPHICAL DISTRIBUTION

The observation that both mitochondrial and nuclear markers show the same subdivision of the sampled individuals, raises the question whether *Pellioditis marina* may comprise several cryptic species. Table 2.3 shows the fixed differences, i.e. the number of base positions at which all sequences of one ‘species’ differ from all sequences of the second ‘species’ (Hey 1991), for both molecular markers between the different clades. PmIII has the highest number of fixed differences in the nuclear ITS marker, while PmII has the highest number of fixed differences in COI.

	PmI	PmII	PmIII	PmIV
PmI	-	29	26	22
PmII	98	-	30	27
PmIII	186	182	-	25
PmIV	37	96	178	-

**Table 2.3.** Number of fixed differences between the four clades for the mtDNA COI fragment above diagonal, and below diagonal for the nuclear ITS region.

The amount of unique fixed differences, i.e. the number of positions at which a species is different from all others (Kliman & Hey 1993), shows the same pattern: PmIII has 155 unique fixed base differences and five unique fixed length differences, which is the highest number for the nuclear marker; PmII has 54 unique fixed base differences and 4 unique length differences, while PmI and PmIV have 18 and 16 unique base differences and no unique length difference (Appendices 2.2 and 2.3). For COI, PmII has the highest amount of unique fixed differences (12), followed by PmIII (10), PmI (7) and PmIV (6) (Appendix 2.1). Fig. 2.1 shows the geographical distribution of each clade along the sampled region. The PmI clade is clearly the most abundant and geographically widespread lineage. It is the dominant lineage within the Westerschelde and Oosterschelde, and is absent from Lake Grevelingen and Plymouth. In Plymouth, only the PmII clade was found and this clade is also abundant in Lake Grevelingen. PmIII is only encountered in the Oosterschelde and PmIV only in Lake Grevelingen. In several of our sample locations, two lineages occurred sympatrically.

#### POPULATION GENETIC STRUCTURE

A significant spatial population genetic structure is found when all sampling locations are pooled. This indicates that migration between the different locations is not sufficient to homogenize the COI gene pool. Of all molecular variation found, 55.9 % ( $\phi_{ST} = 0.559$ ,  $p < 0.0001$ ) is explained by differences among locations (Table 2.4). Omitting the Plymouth population, variation between locations is still significant ( $\phi_{ST} = 0.4471$ ,  $p < 0.0001$ ). The MDS plot of the genetic distances clearly shows a large divergence of the Plymouth and Lake Grevelingen samples: 60.14 % of the variation ( $\phi_{CT} = 0.6014$ ,  $p < 0.05$ ) is caused by differences between Plymouth and lake Grevelingen on the one hand, and the Belgian and Dutch populations on the other hand (Fig. 2.4A). The MDS plot does not change when Plymouth and Lake Grevelingen are omitted, although the percentage of variation explained by differences between the remaining populations decreases to 30.58 % ( $\phi_{ST} = 0.30575$ ,  $p < 0.0001$ ).

	n	%	$\Phi$	p
All sequences	451			
Among populations		55.90	0.56	***
Within populations		44.10		
Pm I	335			
Among populations		18.76	0.19	***
Within populations		81.24		
Pm II	85			
Among populations		47.00	0.05	***
Within populations		53.00		
Pm III	2	-	-	-
Pm IV	29	-	-	-

**Table 2.4.** Hierarchical analyses of variance across ten populations of *Pellioiditis marina*.  $\Phi$  – statistics are calculated for all data combined, and for sequences allocated to their respective clades. (n) number of individuals analysed, (%) percentage variance explained, (p) significance level of  $\Phi$  – statistic (\*\*\* < 0.0001).

When we look at the distribution of the locations within the Westerschelde (Fig. 2.4B), a clear distinction between the most upstream (Kr) and one of the two most downstream locations (Sl) is seen. The highest genetic diversity is found in Sloehaven ( $h = 0.81$ ,  $\pi = 0.181$ ) and the lowest in Kruispolderhaven ( $h = 0.404$ ,  $\pi = 0.003$ ). No significant differentiation is found between the other locations (Breskens, Paulina and Zeedorp,  $\Phi_{ST} = 0.00315$ ,  $p = 0.3$ ) within this estuary. Genetic diversity in these locations is comparable but somewhat higher in Paulina (Table 2.1).

AMOVA was also performed on clades PmI and PmII separately. The MDS – plot in Fig. 2.4C shows the genetic distances of PmI between the sampled locations. The coastal zones (Bl and Ni) are clearly differentiated from the Westerschelde and Oosterschelde populations, and AMOVA indicates a significant differentiation (18.76 %) among the locations ( $\Phi_{ST} = 0.18762$ ,  $p < 0.0001$ ). Within the Westerschelde, PmI is still significantly structured, albeit less pronounced ( $\Phi_{ST} = 0.08475$ ,  $p < 0.0001$ ). This mainly reflects differences between the most upstream location and the three others (Fig. 2.4C). The differentiation with the westernmost coastal location (Ni) is due to the presence of one haplotype unique to that location (haplotype T, except for one individual in Sl). Haplotypes belonging to the PmII clade are also significantly structured, 47 % of the total variation being explained by differences among locations ( $\Phi_{ST} = 0.47003$ ,  $p < 0.0001$ ).

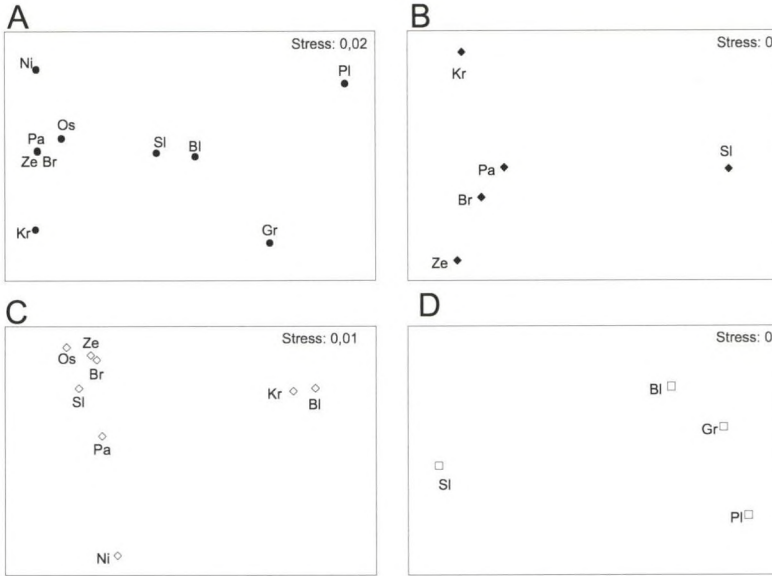

**Fig. 2.4.** *Pellioiditis marina*. Multi-dimensional scaling (MDS) of the Tamura & Nei genetic distance matrix of the COI fragment and its associated stress value. (A) complete dataset (no distinction between clades was made); (B) locations within the Westerschelde (no distinction between clades); (C) clade PmI; (D) clade PmII. For sample location abbreviations see legend Fig. 2.1.

ISOLATION BY DISTANCE

Genetic and geographic distances are correlated when all sampled populations are included ( $r = 0.7178$ ,  $p = 0.007$ ). More than 50 % of the molecular variation is explained by geographic distance ( $R^2 = 0.515$ ). When plotting both distances in a scatter diagram (Fig. 2.5), a clear separation of nematodes from Plymouth and from

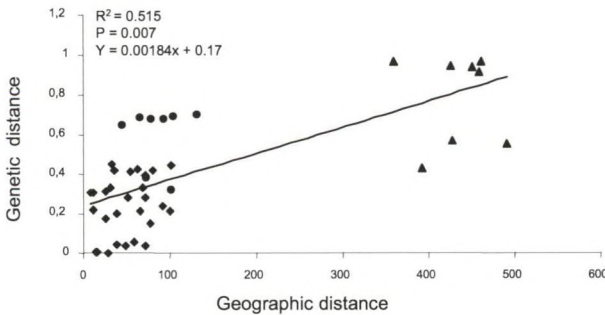

**Fig. 2.5.** Scatterdiagram of geographic distance vs. genetic distance. Population pairs containing Plymouth are indicated with ▲, those containing lake Grevelingen with ●. All other population pairs are indicated with ◆.

Lake Grevelingen is found. Calculating IBD between the populations from Belgium and The Netherlands (and thus omitting the Plymouth population) still gives a significant ( $r = 0.4725$ ,  $p = 0.037$ ), albeit less strong correlation.

## DISCUSSION

## POPULATION GENETIC STRUCTURE

With all data combined, there was a significant population genetic structuring over the sampled area. Even within the Westerschelde, locations were differentiated from each other. The strong differentiation of the Plymouth population (P1, Fig. 2.4A) was caused by the presence of only PmII in this location. At first sight, these results support the idea of limited dispersal abilities in marine nematodes. Free-living nematodes are small, have an endobenthic life style and lack dispersive stages. Active dispersal is therefore restricted. However, *Pellioiditis marina* typically lives on decomposing algae in littoral and coastal environments, and can passively disperse through rafting on floating algae (pers. observation). The dominant currents in the English Channel and the North Sea transport macroalgae from southwest England to the Belgian and Dutch coasts (Turrell 1992, Ducrottoy et al. 2000), and can therefore homogenize populations living on both sides of the North Sea. However, we found a strong differentiation between Plymouth and the Belgian coastal zone, as well as among the stations located in the small area sampled in Belgium and The Netherlands. One possible explanation is that passive dispersal may be inefficient. However, considering the high reproductive potential and short development times of *P. marina* (Vranken & Heip 1983, Moens & Vincx 2000a), even very small founder populations are expected to be sufficient for effective colonisation. Therefore, the genetic structuring on our small geographical scale may rather be explained by repeated colonisation events combined with high reproductive rates (Caudill & Bucklin 2004, De Meester et al. 2002). Monopolisation of resources and local adaptation (which may be prominent in *P. marina*, Moens & Vincx 2000a,b) can then produce persistent genetic structure over small spatial scales in the face of significant gene flow (De Meester et al. 2002).

The differentiation and lower genetic diversity ( $h = 0.404$ ,  $\pi = 0.003$ , Table 2.1) of the most upstream location (Kr) within the Westerschelde may well be linked to the lower salinity and/or higher pollution at this location, rather than by cessation of gene flow. It is in agreement with the range of *P. marina* in the Westerschelde, which extends only just beyond this most upstream sampling location (Moens & Vincx 2000b). However, the salinity gradient in the Westerschelde is paralleled by a

pollution gradient, rendering assignment of species ranges to either factor difficult. Moreover, a whole range of pollutants is present in this estuary with unknown consequences for communities and species living there. Interestingly, De Wolf et al. (2004) also found a correlation of population genetic structure with the salinity / pollution gradient in the Westerschelde for the periwinkle *Littorina littorea*. Toxicants can influence the population genetic structure of a species by mutagenic, physiological or ecological effects, which can lead to a decrease in genetic variation and in frequency of haplotypes (De Wolf et al. 2004). Experimental studies with harpacticoid copepods indicate that severe bottlenecks can occur in populations exposed to toxicants (Street et al. 1998), and environmental history seems to have no effect on their survival ability when copepods are exposed to different concentrations of sediment-associated contaminants (Kovatch et al. 2000). In contrast, Schizas et al. (2001) observed differential survival of three harpacticoid copepod lineages and inferred that this differential survival might explain some of the genetic patterns observed in contaminated habitats.

Contrary to De Wolf et al. (2004), we found no clear differentiation between the Oosterschelde population and the downstream locations in the Westerschelde. Even though there is a storm surge barrier since 1986 between the Oosterschelde and the North Sea, it remains open most of the time. Exchange between neighboring populations remains therefore important. The high degree of genetic differentiation of Lake Grevelingen is caused by the presence of the PmIV lineage, which was absent from all other locations.

#### CRYPTIC SPECIATION

We found a high degree of intraspecific differentiation in the COI gene of *Pellioiditis marina*. Within the Nematoda, intraspecific variation has hitherto only been studied in parasitic species and divergences of the COI gene range from 0.3 – 8.6 % (0.3 – 8.4 % in *Oesophagostomum bifurcum* (de Gruijter et al. 2002), 0.5 – 8.6 % in *Ancylostoma caninum*, 0.3 – 3.3 % in *A. duodenale*, 0.3 - 4.3 % in *Necator americanus* (Hu et al. 2002)). Interspecific divergences within genera range from 4.8 – 13.7 % (11.5 – 13.7 % within *Oesophagostomum*, 4.8 – 12.9 % between *Ancylostoma* and *Necator*). These interspecific values are comparable with the divergences found between the four lineages in the COI gene of *P. marina* (5.8 – 10.6

%, Table 2.2). For comparison, divergences between *P. marina* and its congener *P. ehrenbaumi* range from 7.5 - 9.5 %. Nucleotide differences within lineages are much lower and range from 0.25 - 1.7 %, lower than the above within-species divergences. Furthermore, we found a large amount of fixed differences (= the number of base positions at which all sequences of one lineage differ from all sequences of another lineage) in the COI fragment between our lineages (22 - 29, Table 2.3). Hu et al. (2002) and Zhu et al. (2001) found no fixed differences within sets of populations of *A. duodenale* and *C. ogmorhini* and concluded that these populations belong to the same species. On the other hand, Hu et al. (2002) detected four unequivocal nucleotide positions in a 395bp region of the COI gene between individuals of *N. americanus* from China and Togo, suggesting that these individuals belong to distinct sets of genotypes as a consequence of geographical isolation over a long period of time.

The high levels of COI differentiation between the haplotype groups of *P. marina* are thus in the order of differences found between different species of parasitic nematodes and between congeneric species of *Pellioiditis*. This observation, together with the high amount of fixed differences between these haplotype groups, suggest that the mitochondrial lineages represent different cryptic species of *P. marina*. When morphological stasis persists after speciation events, resulting species may continue to diverge genetically in the absence of morphological differentiation (Rocha - Olivares et al. 2001). Especially in organisms with small body size, the number of taxonomically relevant characters decreases rapidly (Rocha - Olivares et al. 2001).

Analysis of the nuclear ribosomal spacer region is consistent with the hypothesis of cryptic speciation. This region is particularly useful for phylogenies among closely related taxa (taxa that have diverged within the last 50 million years) (Hillis & Dixon 1991), and the region is generally of uniform length and composition within species (Hillis et al. 1991). Sequence differences within each lineage are low (0 - 0.81 %). However, a lot of fixed differences between the four lineages are found (Table 2.3). Lineages PmII and PmIII also contain, respectively, four and five fixed length differences (Appendix 2.2 and 2.3). The concordance between COI and the nuclear marker provides further support that *P. marina* consists of multiple cryptic species using the phylogenetic-species and the genealogical-concordance criteria (Rocha - Olivares et al. 2001). The existence of other cryptic species or intermediate



lineages can not be excluded and additional sampling in time and on a larger geographical scale would probably uncover still more variation in *Pellioditis marina*.

Hybridisation experiments and detailed morphological analysis of the four *P. marina* lineages will be performed to further substantiate and describe these cryptic species<sup>13</sup>. The ease with which *P. marina* can be cultured in laboratory conditions will also enable us to address differences in autecology.

#### DISTRIBUTION OF THE FOUR LINEAGES

On the geographical scale sampled here, clade PmI is the most abundant with an estuarine and coastal distribution (Fig. 2.1). Within PmI, haplotypes A and D are very common within the Westerschelde, except in the most upstream location (Kr), where only a single individual of haplotype D was found. The ‘star like’ pattern within PmI in the minimum spanning network suggests that haplotype J is the oldest haplotype, which gave rise to all other haplotypes of PmI.

Within the Westerschelde, a gradient of decreasing (organic and chemical) pollution occurs towards the sea, and at the same time, salinity increases. *Pellioditis marina* is a marine and brackish water nematode, with an optimal fitness at salinities between 10 and 30. However, these ranges are characteristic of populations rather than of species and local adaptation as well as adaptation to culture conditions may be prominent (Moens & Vincx 2000b). From these results, it seems likely that haplotype A is the most tolerant for a range of salinities. In general, the PmI lineage seems to be more tolerant for fluctuating environmental conditions than the other haplotype groups. Lake Grevelingen has no tides, and in these stable conditions PmIV was the only haplotype group found. PmII was found in much lower frequency than the PmI species and contains many haplotypes which are unique to either Lake Grevelingen or to the Plymouth population. The most abundant haplotype (R1 = 15) was shared between these two locations.

From Fig. 2.1, it is obvious that the four cryptic lineages occur sympatrically. As far as we know, *P. marina* is not a specialist feeder, nor is it constrained to a very strict abiotic environment (Moens & Vincx 2000 a, b). Furthermore, we do not

---

<sup>13</sup> See Chapter 5

exclude that the cryptic lineages occur in a temporal succession, correlating with the decomposition stage of the algae and hence the quality of the organic detritus on which they live. Whether speciation occurred sympatrically or allopatrically cannot be inferred from our data.

### CONCLUSION

Although its active dispersal capacities are extremely limited, *Pellioiditis marina* can disperse passively through rafting on floating algae. Our results suggest that this dispersal is either small or that pulsed colonisation events occur. Therefore, information on life strategies, colonisation potential and local adaptation is as important as knowledge of dispersal ability for interpreting the potential relationship between population genetic structure and dispersal capacity.

Phylogenetic analyses of the mitochondrial COI gene and the nuclear ITS region shows the existence of four cryptic lineages within the morphospecies *P. marina*. This cryptic speciation, found in only a small (100 km) geographical range of *P. marina*, has strong implications for diversity estimates within the Nematoda, which are mainly based on morphological characteristics. Because *P. marina* has a very short generation time with a high reproductive output, extrapolations and generalisations to other nematode species have to be done carefully. Nevertheless, this result does indicate that the real species diversity within the phylum Nematoda is probably much higher than hitherto suggested.

### ACKNOWLEDGEMENTS

S.D. acknowledges a grant from the Flemish Institute for the Promotion of Scientific - Technological Research (I.W.T.). T.M. is a postdoctoral fellow with the Flemish Fund for Scientific Research. Further financial support was obtained from Ghent University in BOF – projects 12050398 (GOA) and 011060002. We gratefully acknowledge Dr. P. Somerfield (Plymouth Marine Laboratory) for his help in the collection of the Plymouth samples.







118957

---

**CHAPTER III**

**SEASONAL DYNAMICS OF POPULATION GENETIC  
STRUCTURE IN CRYPTIC TAXA OF THE *PELLIODITIS MARINA*  
COMPLEX (NEMATODA: RHABDITIDA)**

---

Published as:

Derycke S, Backeljau T, Vlaeminck C, Vierstraete A, Vanfleteren J, Vincx M, Moens T (2006) Seasonal dynamics of population genetic structure in cryptic taxa of the *Pellioditis marina* complex (Nematoda: Rhabditida). **Genetica** 128: 307-321.

### ABSTRACT

The distribution patterns and genetic structure of the *Pellioditis marina* species complex in Belgium and The Netherlands were compared between four consecutive seasons. Different types of habitats (coast, estuary, semi-estuary and lake) with different degrees of connectivity were sampled. In addition, each habitat type was characterized by either temporal or permanent algal deposits. We screened 426 bp of the mitochondrial cytochrome oxidase c (COI) gene with the single – strand conformation polymorphism (SSCP) method in 1615 individuals of *Pellioditis marina*. The 51 haplotypes were divided into four (sympatric) lineages, with divergences ranging from 0.25 % to 10.6 %. Our results show that the lineages have different temporal dynamics, which may be linked to abiotic factors. Analysis of Molecular Variance (AMOVA) indicated a significant structuring in the PmI lineage, which correlated with habitat characteristics and which changed over time (Mantel,  $r = 0.51$ ;  $p = 0.126$ ). Intrapopulational diversity was similar in all locations, and temporal changes in haplotype frequencies were not higher in temporary than in permanent algal deposits. Instead, the results of the temporal survey indicated that (some) *P. marina* populations are characterized by a metapopulation structure. It is emphasized that a complete and correct interpretation of processes causing genetic structuring within species and of the genetic structure itself can only be done when analyzes are performed at several time points.

## INTRODUCTION

Increased interest in the population genetic structure of a wide range of organisms has yielded many new insights in patterns of genetic diversity, of migration and of dispersal abilities in species belonging to very different phyla. For instance, several marine organisms which were long thought to have a homogeneous gene pool over large geographical ranges, have recently been shown to exhibit a substantial degree of genetic differentiation (e.g. Schizas et al. 1999, Kirkendale & Meyer 2004, Ovenden et al. 2004, Remerie et al. 2006a). Moreover, studying genetic variation within species has revealed the existence of substantial intraspecific genetic diversity, indicating the existence of multiple cryptic species (Williams et al. 2001, McGovern & Hellberg 2003, Lee & O' Foighil 2004, Derycke et al. 2005).

Many spatial studies implicitly assume that the observed genetic structure and diversity are stable over time, which is at odds with the effects stochastic processes may have on allele frequencies (Heath et al. 2002, Arnaud & Laval 2004). Hence, accurate interpretation of population genetic structure requires assessment of temporal variability. In turn, information on temporal changes in genetic structure may reveal to what extent natural populations of species exist in dynamic metapopulations, or in stable populations at equilibrium between drift and gene flow (Hoffman et al. 2004). Next to these stochastic processes, selection and migration can also influence allele frequencies (Hartl & Clark 1989). Selection leads to microevolutionary changes as a result of the species' response to environmental changes in its habitat. Therefore, habitat characteristics and demography also play an important role in shaping genetic structure within species (Charbonnel et al. 2002, Bousset et al. 2004). Temporal surveys on population genetic structuring of invertebrate species have been few (e.g. Charbonnel et al. 2002, Bousset et al. 2004, Arnaud & Laval 2004) and have included only few marine species (Barcia et al. 2005, Martinez et al. 2005, Papetti et al. 2005, Remerie et al. 2006a).

*Pellioiditis marina*<sup>14</sup> (Nematoda; Rhabditida) is an obligate outcrosser and typically lives either on dead macrophytes washed ashore and/or on standing macroalgae in sheltered places along coasts and estuaries. Suitable macroalgal thalli are covered with microbial biofilms - bacteria being the main food source for

---

<sup>14</sup> See General Introduction, p 9: *Pellioiditis* is now considered a subgenus of *Rhabditis*



*P. marina* (Moens & Vincx 1997) - and predominantly belong to the genus *Fucus* in our sampling area. The highest densities of *P. marina* are, however, found in piles of decaying algae. While dispersal abilities of nematodes are generally considered to be limited for lack of pelagic stages, these temporal deposits are rapidly colonised. *P. marina* is an opportunistic species with mean and minimum generation times of 7.2 and < 3 days, respectively, under the climatic conditions typical of our study area. Females can produce up to 600 eggs (Vranken & Heip 1983), so even one or a few gravid females should be able to establish viable populations. Hence, metapopulation dynamics are likely to be pronounced in this species. In addition, earlier work showed that *P. marina* actually refers to a complex of at least four cryptic taxa (currently defined as mitochondrial DNA lineages). Until now, no ecological or morphological difference between them has been reported (Derycke et al. 2005). Obviously, this cryptic taxonomic diversity must be taken into consideration when exploring eventual metapopulation dynamics in *P. marina*.

In order to evaluate to what extent metapopulation dynamics govern population genetic structuring in the *P. marina* complex, we analysed the spatiotemporal patterning of mitochondrial DNA COI haplotype frequencies in Belgian and Dutch populations of *P. marina* from different habitats (coastal - estuarine - semi-estuarine - lake) with different degrees of connectivity (from complete isolation to supposedly free exchange between habitats). Furthermore, we compared 'temporary' and 'permanent' habitats. Temporary habitats are algae that have been randomly deposited in the littoral by tidal currents or wind, while permanent habitats are algae attached to dikes and stones.

Three main issues are addressed in this study: (1) mapping the spatiotemporal occurrence of the four cryptic mitochondrial DNA lineages described by Derycke et al. (2005); (2) assessing habitat- related population genetic patterns in the most widespread lineage (PmI), and (3) analyzing the temporal stability/variability of the population genetic structure in PmI.

With respect to the habitat-related population genetic patterns in PmI, we assumed that: (1) the potential for migration and colonisation is higher in coastal and estuarine habitats because of their higher connectivity, and (2) extinction and genetic drift should be more common in temporary than in permanent habitats (Bousset et al. 2004). On this basis we expected that: (1) estuarine populations should be genetically more diverse; (2) temporal variation in haplotype frequencies should be more

pronounced in habitats where algal debris is periodically washed ashore (coastal and lake samples) than in habitats with permanent *Fucus* stands (estuarine samples); (3) differentiation should be stronger between different types of habitats (estuarine – coastal – lake) than between the samples from the estuarine system as a result of different habitat characteristics.

## MATERIAL AND METHODS

### SAMPLE LOCATIONS AND THEIR ECOLOGICAL CHARACTERISTICS

Sample locations of *Pellioditis marina* were situated in Belgium and The Netherlands, all populations being separated by distances of 10-100 km (Fig. 3.1). Different degrees of connectivity are present in our sampling scheme: within the Westerschelde estuary (The Netherlands) five locations (Sl, Br, Pa, Ze, Kr) were sampled along a salinity and pollution gradient; these locations have no apparent physical barriers between them, nor with the two coastal locations in Belgium (Ni, Bl). The Oosterschelde (Os) is regularly separated from the sea by the storm surge barrier, while Lake Grevelingen (Gr) is isolated by permanent geographical and man-made barriers (The Grevelingendam). The history and ecology of the Westerschelde, Oosterschelde and Lake Grevelingen are described in Heip (1989). The nine locations also differ in (1) habitat type (coastal - estuarine – coastal lagoon - lake), (2) the availability of algae throughout the year (permanent vs. temporary), and (3) salinity (averages ranging from 16 to 31 in the Westerschelde, and from 28 to 35 elsewhere). These ecological characteristics are summarized in Table 3.1.

Pop	Locality	Geographical coordinates		Habitat characteristics			
		Latitude	Longitude	environment	salinity	type of algae	presence of algae
Sl	Sloehaven (Westerschelde)	51° 27' N	3° 36' E	estuary	31	<i>Fucus</i> sp.	permanent
Br	Breskens (Westerschelde)	51° 24' N	3° 33' E	estuary	30	<i>Fucus</i> sp.	permanent
Pa	Paulina (Westerschelde)	51° 21' N	3° 49' E	estuary	25	<i>Fucus</i> sp.	permanent
Ze	Zeedorp (Westerschelde)	51° 24' N	3° 58' E	estuary	18	<i>Fucus</i> sp.	permanent
Kr	Kruispolderhaven (Westerschelde)	51° 22' N	4° 3' E	estuary	16	<i>Fucus</i> sp.	permanent
Os	Oosterschelde	51° 36' N	3° 50' E	coastal lagoon	28	<i>Fucus</i> sp.	permanent
Gr	Lake Grevelingen	51° 44' N	3° 57' E	Lake	35	<i>Ulva</i> sp./ <i>Enteromorpha</i> sp.	temporary
Ni	Nieuwpoort	51° 9' N	2° 43' E	coast	33	<i>Fucus</i> sp.	temporary
Bl	Blankenberge	51° 19' N	3° 8' E	coast	31	<i>Fucus</i> sp.	temporary

**Table 3.1.** *Pellioditis marina*. Geographical and ecological characteristics of the nine sampled populations. Average salinity values for the Westerschelde and Oosterschelde were calculated using values from www.waterbase.nl, coastal values were available from the MIDAS database on www.VLIZ.be. Pop = population.

All nine locations were sampled three-monthly in April, July and October 2003 and in January 2004 to evaluate the temporal (in)stability of the populations.

### SAMPLE COLLECTION AND PROCESSING

Suitable fragments of *Fucus* sp. (*Ulva* sp. and *Enteromorpha* sp. at Lake Grevelingen, as *Fucus* sp. was not found here) were randomly collected from an area of approximately 50 \* 50 m within the distribution range of the algae in each location, and pooled in buckets. In the lab, we again randomly took fragments from these buckets and divided them over 50 agar slants which were incubated for about two days. Adult *Pellioiditis marina* were then identified under a dissecting microscope using diagnostic morphological characters (Inglis & Coles, 1961), and handpicked with a fine needle from as many slants as possible. This would ideally lead to one nematode being picked from each slant. In practice, however, *P. marina* are patchily distributed on the algae and hence were found only on part of the agar slants. As a result, an overall average of four nematodes was collected per 'successful' slant. We consider this to be a representative subset of the local population because our sampling procedure ensures that nematodes were collected from a variety of patches within this local population. As such, 'populations' in this study conform to our sampling locations. All individuals were photographed digitally as a morphological reference and then stored in acetone (70 – 95 %) until processed.

### GENERATING THE MOLECULAR DATA

On average 45 individuals were processed for each location and season. Exceptions were Lake Grevelingen in July 2003 (n = 18) and Nieuwpoort (n = 26) and Blankenberge (n = 34) in January 2004 (Table 3.2).

DNA extraction and characterisation of genetic variation were performed as described in Derycke et al. (2005). In short, after DNA extraction, 426 bp of the mitochondrial cytochrome oxidase c subunit 1 (COI) gene were amplified with primers JB3 and JB4.5 (Hu et al. 2002). Nematodes from Lake Grevelingen and a large number of individuals from the July campaign were amplified with primers JB3 and JB5 (Derycke et al. 2005). Variation in the COI fragment was detected using the Single Strand Conformation Polymorphism (SSCP) method (see Zhu & Gasser 1998 for a description of the method used). PCR and SSCP conditions were as in Derycke

et al. (2005). All samples with different SSCP-profiles were sequenced with both the forward and reverse primers mentioned above. Conformity between band mobility and sequence variability was checked by additionally sequencing 10 % of the samples in every location. Two haplotypes (X1,  $n = 2$  in SI and X2,  $n = 1$  in Ni) were indistinguishable on SSCP from the common haplotype J and differed from it by 1 base substitution. These two haplotypes (Accession numbers: AM085439 and AM085440 for X1 and X2 respectively) were included for phylogenetic analyses, but omitted from the dataset for all other analyses.

PCR products were purified with shrimp alkaline phosphatase ( $1 \text{ U } \mu\text{l}^{-1}$ , Amersham) and exonuclease I ( $10 \text{ U } \mu\text{l}^{-1}$ , Amersham) and cycle sequenced using BigDye V3.1 Terminator Mix (PE Applied Biosystems). Electrophoresis was conducted on a Perkin Elmer ABI Prism 377 automated DNA sequencer. After trimming both ends of the sequences, we obtained a fragment of 396 bp.

New sequences that have not been reported by Derycke et al. (2005) were submitted to GenBank (accession numbers AM076731 – AM076741; AM076817 – AM076824, Table 3.2).

#### DATA ANALYSIS

##### Genetic diversity and phylogenetic analysis

Sequences were aligned with the Clustal X program v.1.74 (Thompson et al. 1997). Nucleotide ( $\pi$ , Nei 1987) and haplotype ( $h$ , Tajima 1983, Nei 1987) diversities were calculated with Arlequin v.2.0. (Schneider et al. 2000). Pairwise differences between sequences were calculated in Mega 3.0 (Kumar et al. 2004). To test if intrapopulation genetic diversity differed significantly among habitats, non-parametric Kruskal-Wallis tests were applied to mean  $h$  or  $\pi$  values over habitats, using the Statistica 5.5 program (Statsoft Inc. 2000). Changes in haplotype frequencies between temporal samples of a given population were evaluated using an exact test of population differentiation implemented in Arlequin v.2.0 (Schneider et al. 2000). Phylogenetic analyses of the haplotype sequences were performed with the Paup\* 4.0 beta 10 program (Swofford 1998). MODELTEST 3.7 (Posada & Crandall 1998) was used to select the best substitution model for our data, using the corrected Akaike Information Criterion (AICc, Posada & Buckley 2004). The K81uf+G model (Kimura 1981), corrected for unequal base frequencies and unequal rate variation

among sites (G), best fitted our mitochondrial data (AICc score = 3188.2075, Akaike weight = 0.3178). Unrooted maximum parsimony (MP, 10000 rearrangements) and maximum likelihood (ML, 10000 rearrangements) trees were constructed via random stepwise addition (10 replicate trials) and a tree-bisection-reconnection branch swapping algorithm. One tree was held at each step. Bootstrap values for MP and NJ were calculated from 1000 replicates, and for ML from 100 replicates.

### Spatiotemporal analysis of haplotype frequencies

Spatiotemporal variation in haplotype frequencies among and within populations was analysed with a hierarchical AMOVA, and by calculating pairwise  $F_{st}$  values between populations as implemented in Arlequin v.2.0 (Schneider et al. 2000).

AMOVA was performed at several levels, based on haplotype frequencies. We refer to 'two-level AMOVA' when seasons were nested within populations, and to 'single-level AMOVA' when no nesting was performed. Single - level AMOVA's using conventional F-statistics were conducted to look at (1) the temporal differentiation within each location for each mitochondrial DNA lineage (Table 3.4); (2) the spatial differentiation in each season for the PmI lineage (Table 3.5). A two-level AMOVA was performed to compare the temporal and spatial differentiation (1) in the PmI, PmII and PmIII lineage (Table 3.3), and (2) in each habitat type for the PmI lineage (Table 3.6). The significance of the variance components was assessed by comparing the observed distribution with a 'random distribution' generated by permuting haplotypes (10000 times) among populations and among groups of populations (Excoffier et al. 1992). Differences between  $F_{st}$  values from temporary and permanent habitat types were assessed with a t-test for independent samples using Statistica 5.5 (Statsoft Inc. 2000).

Cavalli-Sforza & Edwards' (1967) (DCE) chord distances between all samples containing PmI haplotypes were calculated in Phylip 3.6 (Felsenstein 2004), and were visualized in a nonmetric multidimensional scaling-plot, superimposed by a minimum spanning tree, using NTSYS v 2.11 (Rohlf 2000).

The temporal stability of population structuring within lineage PmI was tested as follows: (1) differences in overall spatial genetic differentiation ( $F_{st}$ ) between populations among the four seasons were tested with the randomisation procedure (10000 permutations) implemented in Fstat v 2.9.3 (Goudet 2001); (2) matrices of

DCE chord genetic distances between seasons were compared with a Mantel test (1000 permutations) as implemented in TFPGA 1.3 (Miller 1997) to evaluate whether genetic distances were similar between seasons (Hoffman et al 2004).

In addition, the isolation-by-distance model was tested within the PmI lineage with the program IBD 1.5 (Bohonak 2002). Geographic distance was measured as the shortest continuous water surface distance, and was compared with the DCE genetic distances. For IBD analysis, Os and Gr were omitted from the dataset: besides distance, they also show other habitat characteristics (differences in isolation, substrate, tides, ...) which could affect the IBD results. IBD was calculated for the PmI lineage in each season separately. The strength of the IBD relationship was determined with a Reduced Major Axis (RMA) regression (Bohonak 2002). Where applicable, significance levels of p-values were corrected for multiple comparisons according to the sequential Bonferroni method (Rice 1989).

**Fig. 3.1:** *Pellioditis marina*. Distribution of the 4 lineages (PmI, PmII, PmIII and PmIV). For each location, a stacked column graph indicates the percentage of each lineage occurring in spring 2003, summer 2003, autumn 2003 and winter 2004. For sample abbreviations see Table 3.1. Note the small proportion of PmIII during winter 2004 in Br.

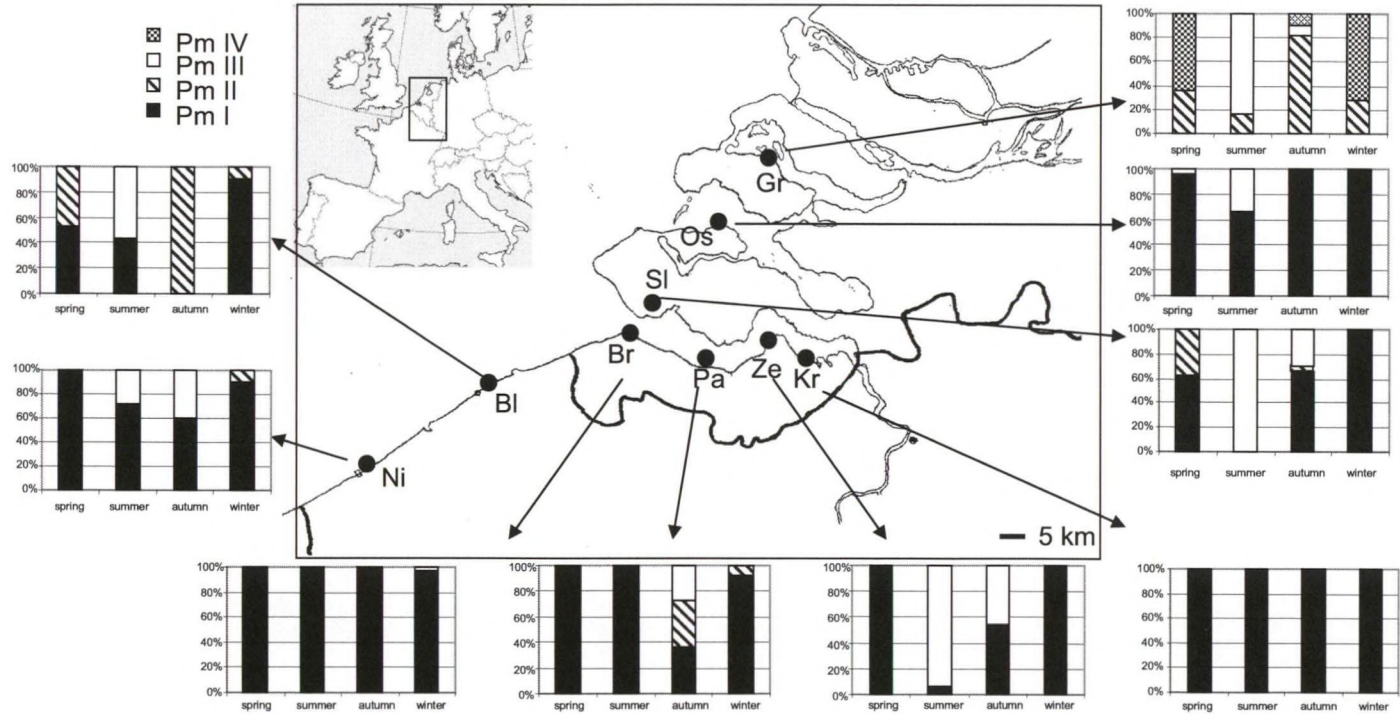

## RESULTS

### GENETIC DIVERSITY AND PHYLOGENETIC ANALYSIS

Sequence variation in 396 bp of the mitochondrial COI gene was analysed in 1615 individuals of the morphospecies *Pellioditis marina*. There were 95 variable sites (23.7 %), 68 of which were parsimony informative. This yielded 51 different haplotypes, 20 of which were new compared to the April 2003 campaign (cf. the 19 haplotypes with an accession number beginning by AM in Table 3.2 and the haplotype X2) (Derycke et al. 2005). The evolutionary relationships among all haplotypes are shown in Fig. 3.2. The MP tree clearly differentiates four distinct haplotype groups (PmI, PmII, PmIII and PmIV), with divergences ranging from 0.25 – 2.3 % within, and from 5.3 – 10.6 % between groups (Table 3.7). In addition, three haplotypes (Z, Z2 and Z3) are highly divergent from the four haplotype groups as well as from each other. The lineages PmI, PmIII and PmIV are supported by high bootstrap values, while the PmII haplotypes received low bootstrap support. Of the 20 new haplotypes, eight belonged to lineage PmII. To evaluate whether taxon sampling could be the cause of the low bootstrap support of this lineage, the trees were recalculated with only PmII haplotypes from the April 2003 campaign and without the highly divergent Z haplotypes. This resulted in bootstrap values of 100, 99 and 100 (MP, NJ and ML resp.) for lineage PmII (data not shown). The Z haplotypes and the PmII haplotypes differ in one distinct amino acid change (Valine to Leucine) from the PmI, PmIII and PmIV lineages.

### SPATIOTEMPORAL DISTRIBUTION OF THE FOUR CRYPTIC LINEAGES (PmI, PmII, PmIII AND PmIV)

From Fig. 3.1, it is clear that PmI is the most abundant lineage in every season (69.84 % of all individuals analysed belong to this lineage), even though this does not imply that it is always present or highly abundant in each location. Peak relative abundances were observed in spring (79.8 %) and winter (85.7 %). Despite this high overall dominance, PmI was not found at Gr, while it is the only lineage found at Kr and at Br (except one individual out of 186 for this last location). The PmII lineage was most frequent in autumn (23.2 %), and was mainly found at Bl and Gr. It was



relatively rare in the estuarine samples. The PmIII lineage had the highest relative abundance in summer (42.17 %), while it was sparse in spring (0.47 %) and even completely absent in winter. Finally, the PmIV lineage was restricted to Gr, where it reached a peak abundance during winter (72.34 % of the Gr individuals). Up to three lineages could be found jointly at the same site, but the timing and frequency of the different combinations varied over the course of a year and did not reveal any obvious consistent pattern.

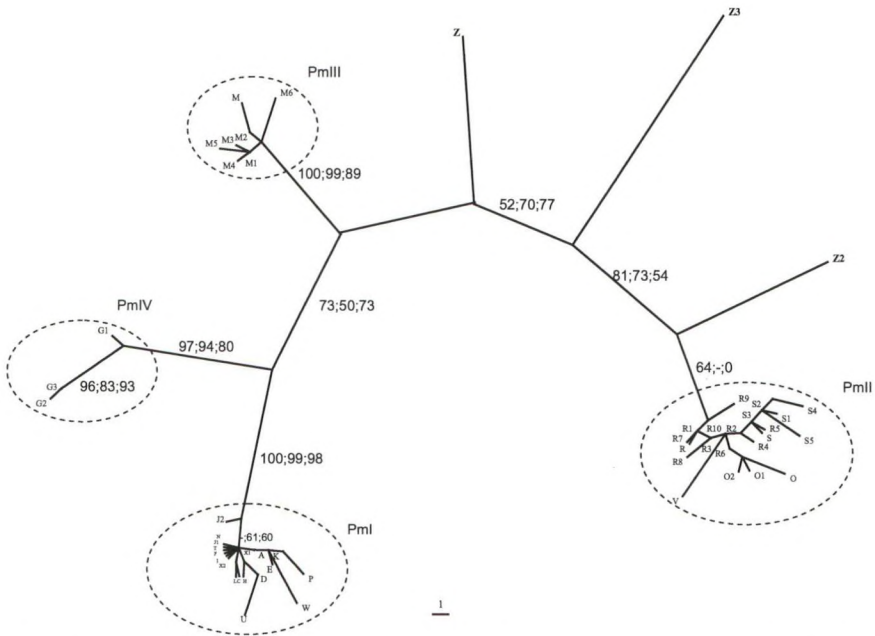

**Fig. 3.2:** *Pellioditis marina*. Unrooted heuristic maximum parsimony phylogram of the 53 mitochondrial COI haplotypes. Bootstrap values above branches are from maximum parsimony, neighbour joining and maximum likelihood analyses resp. ‘—’ indicates bootstrap values lower than 50 and ‘0’ indicates that the branch was not present in the analyses. The genotypic clusters PmI, PmII, PmIII and PmIV are indicated with dashed lines.



SPATIAL VERSUS TEMPORAL VARIATION IN HAPLOTYPE FREQUENCIES WITHIN THE FOUR MITOCHONDRIAL LINEAGES

Because PmIV was only found at Gr, geographical differentiation within this lineage could not be assessed.

Lineage	source of variation	%	statistics	p
Lineage PmI	Among populations	10.70	Fct = 0.11	< 0.0001
	Among seasons within populations	9.54	Fsc = 0.11	< 0.0001
	Within populations	79.76	Fst = 0.20	< 0.0001
Lineage PmII	Among populations	5.50	Fct = 0.05	ns
	Among seasons within populations	21.15	Fsc = 0.22	< 0.0001
	Within populations	73.35	Fst = 0.27	< 0.0001
Lineage PmIII	Among populations	2.23	Fct = 0.02	ns
	Among seasons within populations	21.27	Fsc = 0.22	< 0.001
	Within populations	73.50	Fst = 0.23	< 0.0001

The two-level AMOVA's for each lineage separately indicate that geographical differentiation is prominent only within the PmI lineage (see next section and Table 3.3). This geographical component explains a similar amount of the observed variation as the temporal component (10.70 % vs. 9.54 %, Table 3.3). Differentiation due to temporal variation was large and highly

**Table 3.3.** *Pellioditis marina*. Two-level AMOVA for lineage PmI, PmII and PmIII. F-statistics were calculated for each mitochondrial DNA lineage separately. (%) percentage variance explained; (p) significance level, (ns) not significant.

significant in the PmII and PmIII lineages, explaining, respectively, 21.15 % and 21.27 % of the total variation (Table 3.3). Temporal differentiation occurs in both temporary deposits and permanent algal stands for each mitochondrial DNA lineage (Table 3.4). When Fst values from Table 3.4 were pooled by lineage according to habitat type (permanent vs. temporary), no significant differences were obtained with a t-test, indicating that temporal differentiation was not significantly higher in temporary algal deposits than in the permanent algal stands.

Habitat type	Pop	Lineage	#	n	%	Fst	p	Lineage	#	n	%	Fst	p	Lineage	#	n	%	Fst	p	Lineage	#	n	%	Fst	p	
Coast	Ni	Pm I	4	130	14.26	0.14	***	Pm II	1	3	-	-	-	Pm III	2	30	1.25	0.01	ns	PmIV	-	-	-	-	-	
Coast	Bl	Pm I	3	70	13.12	0.13	**	Pm II	3	66	25.46	0.25	***	-	Pm III	1	24	-	-	-	PmIV	-	-	-	-	-
Estuary	Sl	Pm I	3	110	12.80	0.13	***	Pm II	2	19	58.89	0.59	ns	-	Pm III	2	71	34.94	0.35	***	PmIV	-	-	-	-	-
Estuary	Pr	Pm I	4	185	7.83	0.08	***	Pm II	-	-	-	-	-	Pm III	1	1	-	-	-	PmIV	-	-	-	-	-	
Estuary	Pa	Pm I	4	154	3.86	0.04	**	Pm II	2	20	26.02	0.26	**	-	Pm III	2	12	-	-	-	PmIV	-	-	-	-	-
Estuary	Ze	Pm I	4	124	7.51	0.08	***	Pm II	-	-	-	-	-	Pm III	2	62	13.53	0.14	**	PmIV	-	-	-	-	-	
Estuary	Kr	Pm I	4	185	24.82	0.25	***	Pm II	-	-	-	-	-	Pm III	-	-	-	-	-	PmIV	-	-	-	-	-	
Semi-estuary	Os	Pm I	4	170	1.22	0.01	ns	Pm II	-	-	-	-	-	Pm III	2	19	4.95	0.05	ns	PmIV	-	-	-	-	-	
Lake	Gr	Pm I	-	-	-	-	-	Pm II	3	64	14.43	0.14	***	-	Pm III	2	18	39.69	0.40	**	PmIV	4	67	7.92	0.08	*

**Table 3.4:** *Pellioditis marina*. Single - level AMOVA for the mitochondrial DNA lineages PmI, PmII, PmIII and PmIV. (Pop) population: abbreviations as in Table 3.1. (#) number of temporal samples; (n) number of individuals analysed for each location; (%) percentage of the variance explained by temporal differences in each location; (p) significance-level of the F - statistic: ns = not significant, \* < 0.05, \*\* < 0.01, \*\*\* < 0.001.

SPATIOTEMPORAL VARIATION AMONG HAPLOTYPES OF THE *PmI* LINEAGE

source of variation	%	Fst	p
<b>Spring</b>			
Among populations	18.51	0.19	***
Within populations	81.49		
<b>Summer</b>			
Among populations	26.94	0.27	***
Within populations	73.06		
<b>Autumn</b>			
Among populations	25.45	0.25	***
Within populations	74.55		
<b>Winter</b>			
Among populations	14.71	0.15	***
Within populations	85.29		

**Table 3.5:** *Pellioiditis marina*. Single-level AMOVA for calculating the genetic structure of lineage *PmI* in each season. (%) percentage of the variance explained by; (p) significance-level of the F – statistic (Fst); \*\*\* < 0.001

seasons showed that this level of spatial differentiation did not change significantly among seasons (Fstat,  $p = 0.47$ ). A detailed analysis of the spatial structure within *PmI* revealed a significant differentiation even within the Westerschelde and in every season (data not shown). *Bl* was differentiated from two locations within the Westerschelde: *Pa* on the one hand (Fct = 0.134,  $p < 0.05$ ) and *Sl* on the other (Fct = 0.0523,  $p < 0.001$ ), leading to a low but significant differentiation between the *Bl* and Westerschelde populations (Fct = 0.06,  $p < 0.05$ , Table 3.6). For comparison, the spatial differentiation between *Bl* and

The genetic diversity indices ( $h$  and  $\pi$ , Table 3.2) did not differ significantly among the eight *PmI* populations (Kruskal – Wallis test:  $p = 0.0645$  and  $p = 0.1225$  for  $h$  and  $\pi$  respectively). On average, the highest diversity was observed at *Pa* ( $h = 0.7861$  and  $\pi = 0.0074$ ) and the lowest at *Bl* ( $h = 0.4335$  and  $\pi = 0.0033$ ). Spatial differentiation for *PmI* was apparent in every season (Table 3.5), and permuting the spatial differentiation among

source of variation	%	statistics	p
Among Br, Sl, Pa, Ze, Kr	1.40	Fct = 0.01	ns
<b>Among seasons</b>			
within populations	11.40	Fsc = 0.11	***
Within populations	87.20	Fst = 0.13	***
Among Ws / Os	11.29	Fct = 0.11	**
<b>Among seasons</b>			
within populations	9.99	Fsc = 0.11	***
Within populations	78.72	Fst = 0.21	***
Among Ni / Bl	29.59	Fct = 0.30	*
<b>Among seasons</b>			
within populations	9.93	Fsc = 0.14	***
Within populations	60.48	Fst = 0.40	***
Among Ws / Bl	6.00	Fct = 0.06	*
<b>Among seasons</b>			
within populations	11.95	Fsc = 0.13	***
Within populations	82.05	Fst = 0.18	***
Among Ni / Ws	6.81	Fct = 0.07	**
<b>Among seasons</b>			
within populations	11.24	Fsc = 0.12	***
Within populations	81.95	Fst = 0.18	***
Among Bl / Os	36.39	Fct = 0.36	*
<b>Among seasons</b>			
within populations	2.31	Fsc = 0.04	***
Within populations	61.29	Fst = 0.39	***

**Table 3.6:** *Pellioiditis marina*. Two-level AMOVA for calculating genetic differentiation within lineage *PmI* between the different habitat types. (%) percentage of the variance explained by; (p) significance level of the F – statistic (Fst); (ns) not significant, \* < 0.05, \*\* < 0.01, \*\*\* < 0.001.

Ni or between Bl and Os was much higher: 29.59 % ( $p < 0.05$ ) and 36.39 % ( $p < 0.05$ ), respectively. Overall, differentiation between the different habitat types (estuarine – semi-estuarine – coastal) was moderate, though significant (Table 3.6). The distribution and frequency of the PmI haplotypes in the eight locations are presented in Appendix 3.1. To test whether the observed spatial differentiation was correlated with geographic distance, IBD was tested in every season (omitting Os). Geographic and DCE genetic distances were only correlated in autumn ( $p = 0.01$ ), and this correlation only just remained significant after Bonferroni correction. When Bl and Ni were omitted from the analysis, no IBD pattern was found within the Westerschelde ( $p = 0.12$ ). In addition, DCE genetic distances were not correlated with each other among seasons, indicating that the genetic structure was not stable over time.

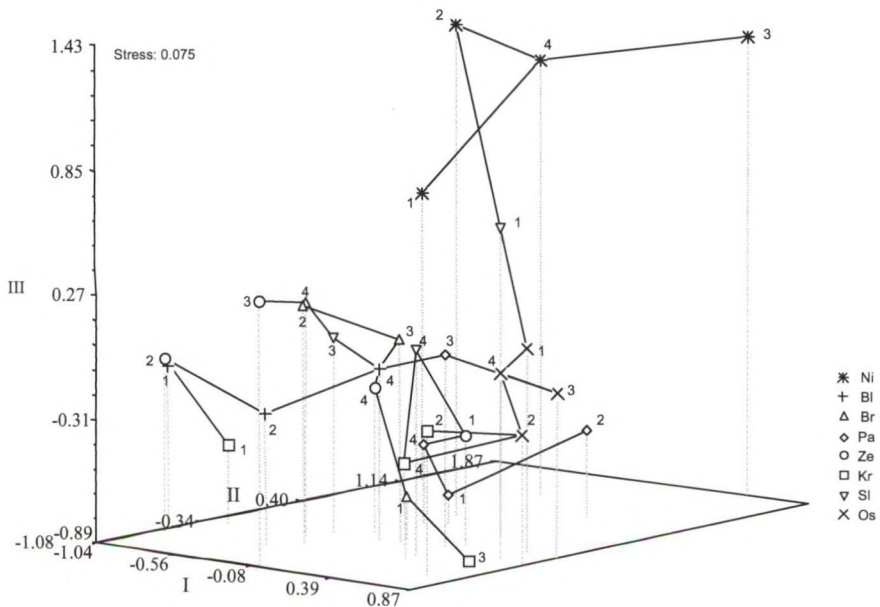

**Fig. 3.3:** *Pellioditis marina*. Lineage PmI. Minimum spanning tree (MST) superimposed on a nonmetric multi – dimensional scaling (nMDS) of the DCE distances between all temporal and spatial samples. Sample abbreviations are as in Table 3.1. Sl from summer and Bl from autumn are missing, as PmI was not found in these locations at that time.  
1 = spring; 2 = summer; 3 = autumn; 4 = winter

The nonmetric multidimensional scaling (nMDS) ordination of all temporal samples of the PmI lineage did not group the populations according to season or algal availability, but illustrated the outlier position of the Ni samples and the high similarity between the Os samples (Fig. 3.3). Exact tests of population differentiation

indicated that haplotype frequencies changed with time for every population ( $p < 0.0001$ ), except for Os ( $p = 0.33$ ).

## DISCUSSION

### GENETIC DIVERSITY AND PHYLOGENETIC ANALYSIS

A previous study of the genetic structure of *P. marina* in the same locations already uncovered four sympatric mitochondrial DNA lineages (PmI, PmII, PmIII and PmIV), which are considered phylogenetic and genealogical species<sup>15</sup>. The cyto-nuclear disequilibrium between COI and ITS data further indicates that they are also reproductively isolated (Derycke et al. 2005). The present study adds 20 new haplotypes, the majority of which belong to the PmII and PmIII lineages (resp 8 and 6). Such high intraspecific variability has also been observed in plant- and animal-parasitic nematode species (Picard et al. 2004; Høglund et al. 2004; Nieberding et al. 2005). Our results support the idea that free-living nematodes are even more speciose than previously thought. In contrast, analysis of population genetic structure in the free-living soil nematode *Caenorhabditis elegans* revealed low levels of intraspecific diversity, despite a high level of outcrossing (Sivasundar & Hey 2005).

The low bootstrap support for the PmII lineage is likely the result of a taxon sampling effect (see e.g. Nylander 2001), in view of the high support obtained when only haplotypes from the April campaign are used. Additionally, the phylogenetic signal of PmII can be reduced by the higher intraspecific variation (2.3 %) observed within this lineage. As ITS sequences gave concordant tree topologies (Derycke et al. 2005) and MP and ML analyses of the COI data were consistent, we do not consider long-branch attraction to be important (Omilian & Taylor 2001, Anderson & Swofford 2004). A proper appraisal of the taxonomic status of the three Z-haplotypes also requires analysis of nuclear DNA sequence information<sup>16</sup>. While the cryptic lineages Pm I-IV were already uncovered by sampling in a single season, the addition of the divergent Z-haplotypes by our seasonal sampling campaign shows that sampling with substantial spatial (including different habitats) and temporal resolution

---

<sup>15</sup> See Chapter 2

<sup>16</sup> See Chapter 6

is required to adequately map and understand cryptic diversity within the *P. marina* species complex.

### SPATIOTEMPORAL DISTRIBUTION OF FOUR CRYPTIC LINEAGES

Each cryptic mitochondrial DNA lineage reaches its highest relative abundance in a different season (Fig. 3.1). This suggests that the lineages at least have different temporal dynamics - whether these dynamics are in fact linked to seasonality can not be inferred from our data- which may reflect temporal changes in environmental and / or biotic factors. Regarding to abiotic conditions, salinities above 10 seem to have little effect on the overall fitness of *P. marina* (most likely PmI; Moens, pers. comm.), while temperature effects are more important (Tietjen et al. 1970, Moens & Vincx 2000a,b). Some *P. marina* populations thrive well at temperatures that are lethal for other populations. Besides local adaptation and phenotypic plasticity, this could be related to different temperature preferences among the cryptic taxa within *P. marina* (Moens & Vincx 2000a). Differential survival of cryptic lineages in other invertebrates to different types of pollutants has also been described (Sturmbauer et al. 1999, Kovatch et al. 2000, Schizas et al. 2001, Rocha-Olivares et al. 2004), but it is doubtful whether this could account for the predominance of the PmI lineage, the other lineages being no less abundant in the polluted Westerschelde estuary than elsewhere. Differential distribution patterns of the Pm lineages could also be influenced by biotic components: PmIV for instance was hitherto only found on the single location where we sampled green instead of brown algae, hence it is possible that lineage PmIV has been overlooked in the other locations because of our choice of sampling substrate. Additional sampling of these *Ulva/ Enteromorpha* deposits outside Lake Grevelingen is required to elucidate the role of substrate (and possible ecological speciation) in the distribution of these lineages.

The restriction of lineage PmIV to Gr and the absence there of lineage PmI could theoretically also reflect allopatric speciation. While possible in view of the isolation of Lake Grevelingen by geographical and man-made barriers since 1964-

1971 (Heip 1989), we consider allopatric speciation<sup>17</sup> unlikely: a mean generation time of 6 days (Vranken & Heip 1983), a substitution rate of  $9.7 * 10^{-8}$  site<sup>-1</sup>generation<sup>-1</sup> (Denver et al. 2000, based on a nematode of the same family as *P. marina*) and 396 sites, yield ~0.095 substitutions since the isolation of Lake Grevelingen, whereas the true number of substitutions between PmI and PmIV ranges from 21-28 (Table 3.7).

	Pm I	Pm II	Pm III	Pm IV	Z	Z2	Z3
Pm I	<b>0.25 - 1.5</b>						
Pm II	7.3 - 10.6	<b>0.25 - 2.3</b>					
Pm III	6.3 - 8.3	7.8 - 10.3	<b>0.25 - 1.3</b>				
Pm IV	5.3 - 7.1	7.8 - 9.6	6.6 - 7.3	<b>0.25 - 1.3</b>			
Z	9.1 - 10.6	6.6 - 8.1	6.8 - 7.1	8.1 - 8.3	-		
Z2	9.3 - 9.8	4.5 - 5.5	8.3 - 9.1	9.1 - 9.6	7.3	-	
Z3	8.8 - 9.8	6.3 - 8.6	9.1 - 9.8	9.3 - 9.6	8.3	8.6	-

**Table 3.7.** *Pellioiditis marina*. Divergence ranges (%) for the 396 bp COI fragment. Below diagonal are values between mitochondrial DNA lineages and the divergent Z haplotypes, values in bold are divergence ranges within each mitochondrial DNA lineage.

#### POPULATION GENETIC STRUCTURE OF PmI

Genetic structuring between populations of lineage PmI is observed in every season, and although the degree of spatial differentiation among populations remains constant, the genetic structure as such does not. First, the among-seasons component of the haplotypic variance is similar to the among-populations component (AMOVA, 9.54 % vs. 10.70 %, respectively). Such similarity has also been observed in steelhead trout (Heath et al. 2002), but is at variance with results for the estuarine copepod *Acartia tonsa*, in which geographical structuring clearly exceeded temporal differentiation (Caudill & Bucklin 2004). However, this result may be caused by differences in the geographical and temporal sampling scales. Secondly, pairwise DCE distances across seasons are not correlated. Such a correlation has been taken as evidence for temporal stability of population genetic structure (Hoffman et al. 2004). Finally, in our study, genetic structuring could only be explained by the IBD model in one season. This result indicates that factors other than geographic distance are important, e.g. evolutionary forces (e.g. Jorde & Ryman 1996, Heath et al. 2002) and/or environmental characteristics (Perrin et al. 2004, Bousset et al. 2004, Barcia et

<sup>17</sup> The phylogeographic study in Chapter 9 does, however, point to an allopatric speciation at large geographical scales.



al. 2005). A geographical survey at one time point is clearly insufficient to adequately describe the spatial structuring in *P. marina* (and see Heath et al. 2002). The instability of spatial differentiation in *P. marina* is most clearly reflected in the differentiation between the Oosterschelde and Westerschelde. Haplotype frequencies within lineage PmI change over time in each population, except for Os (Table 3.4). Although such changes do not necessarily imply changes in population genetic structure (Arnaud & Laval 2004), they clearly do so in lineage PmI. In addition, the lower genetic diversity in the most upstream location within the Westerschelde (Derycke et al. 2005, and also observed in *L. littorea*, De Wolf et al. 2004) is consistent in all seasons. This location lies at the limits of the estuarine distribution of *P. marina* (Moens & Vincx 2000a) and is characterized by high fluctuations in salinity and by strong pollution (Baeyens 1998, Baeyens et al. 1998). These conditions can lead to lower genetic diversity as a result of density reductions in the population (De Wolf et al. 2004). When *P. marina* is exposed to cadmium concentrations similar to those at Kr, population densities are clearly lower than when exposed to cadmium concentrations present at Pa (Derycke et al. 2007b).

A second aim of this study was to assess whether the genetic composition of the populations would correlate with general habitat characteristics. Even a preliminary environmental characterisation can sometimes predict population variability (Bousset et al. 2004 Perrin et al. 2004). First of all, we expected a larger number of haplotypes in the estuarine samples because of higher exchange possibilities and because of the permanent availability of suitable substrata. However, the diversity was not significantly different between any of our sampling locations, suggesting large local population sizes and rendering any effects of genetic drift minimal. In contrast, genetic diversity in two freshwater snail species did correlate with habitat openness (Charbonnel et al. 2002, Bousset et al. 2004). However, these studies used microsatellite data, which because of the larger effective sequence information is probably more powerful in detecting (minor) population genetic variability than mitochondrial DNA (Kanda & Allendorf 2001).

Secondly, we also expected a higher temporal variability in the coastal locations which are characterized by only temporary substratum availability (algal deposits). This was again not supported by our data:  $F_{st}$  values from temporal vs. permanent populations were not significantly different, a result also found in the freshwater snail *Physa acuta* (Bousset et al. 2004). The lower than expected temporal

differentiation suggests that temporary populations never go extinct. *P. marina* forms metabolically less active dauer larvae when conditions turn unfavourable (e.g. when microbial activity declines, Bongers & Bongers 1998). If these dauer larvae (or eggs and other resting stages) are present and survive in the sediment, they may constitute some kind of *P. marina* stock, from which new algal deposits can be colonized. However, data of colonisation experiments suggest that such a 'sediment stock' is rather unlikely, as we repeatedly failed to isolate *P. marina* after inoculation of cleaned (with all fauna removed) fresh and decomposing algae on sediment collected at the Pa sampling site (Derycke et al. 2007b). The absence of any temporal differences in Os is in line with what we expected: this location is more stable due to reduced tidal effects, is 'clean' (Heip 1989), and contains permanent algal stands.

Thirdly, we expected a stronger differentiation between the different habitat types than between the different locations within the Westerschelde. This was confirmed by our data (Table 3.6), suggesting that genetic structuring within lineage PmI is correlated with environmental characteristics. However, the genetic structuring even within the Westerschelde estuary is remarkable, considering the life history characteristics of *P. marina*: its high reproductive output, short generation time and low juvenile mortality (Vranken & Heip 1983) make it a potentially good colonizer (Bongers & Bongers 1998). Furthermore, passive dispersal via drifting algae occurs (Derycke pers. obser.). *P. marina* is therefore able to quickly colonize new (empty) patches, which are prominently available in estuarine and coastal habitats. Results of a field experiment in the Westerschelde indeed indicate that empty algal deposits are rapidly colonized at substantial densities by PmI (Derycke et al. 2007c). Large census and effective sizes are therefore expected in the field, rendering the importance of genetic drift rather small. If changes in allele frequencies are the result of population turnover, rather than of genetic drift, than metapopulation dynamics are likely to occur (Hanski 1991, Ostergaard et al. 2003, Mc Elroy et al. 2003). We therefore conclude that populations of *P. marina*, and more specific lineage PmI, shows a metapopulation structure (except in Os), with colonisation of new patches of algae and subsequent extinction of older, completely decomposed patches.

### CONCLUSION

In conclusion, habitat type and the ecological factors addressed here seem to be of minor importance for predicting the intrapopulation genetic diversity ( $h$ ,  $\pi$ ) within *P. marina*, indicating that large population sizes are maintained at every location (except in the most upstream location in the Westerschelde). More specifically, the temporal/permanent character of algae and connectivity between populations<sup>18</sup> correlate with the genetic structure of *P. marina*. Moreover, this study shows that population genetic structure within species is not necessarily stable over time and that underlying, fine-scale patterns and processes can clearly be misinterpreted when only one time point is analysed. On the basis of our temporal survey, we conclude that lineage PmI most likely exhibits a metapopulation structure, except at Os.

Furthermore, our data also indicate that sampling all possible (micro)habitats, including different substrates, and broadening the geographical and temporal scale is necessary to fully understand the effects of micro-evolutionary forces on genetic structuring and speciation. In addition, the temporal dynamics of the four lineages within *P. marina* raise questions as to what extent their abundances are correlated with seasons and what the role is of temporal isolation in this taxonomic differentiation.

### ACKNOWLEDGEMENTS

The authors thank Dr. T. Remerie for his suggestions and help in retrieving and analyzing the data. S.D. acknowledges a grant from the Flemish Institute for the Promotion of Scientific- Technological Research (I.W.T.). T.M. is a postdoctoral fellow with the Flemish Fund for Scientific Research. Further financial support was obtained from Ghent University in BOF – project 01GZ0705 (GOA-BBSea).

---

<sup>18</sup> We here mean that the unstable character and the patchy distribution of the algae together with abiotic differences between coastal, estuarine and lake locations best explain the population genetic structuring in PmI

**Appendix 3.1:** *Pellioditis marina*. Distribution of the Pml haplotypes among the eight sampling locations: the eight most abundant haplotypes are shown separately, while the other nine rare haplotypes are pooled together (grey). Ni: Nieuwpoort; Br: Blankenberge, Br: Breskens, Pa: Paulina, Ze: Zeedorp, Kr: Kruispolderhaven, Sl: Sloohaven, Os: Oosterschelde

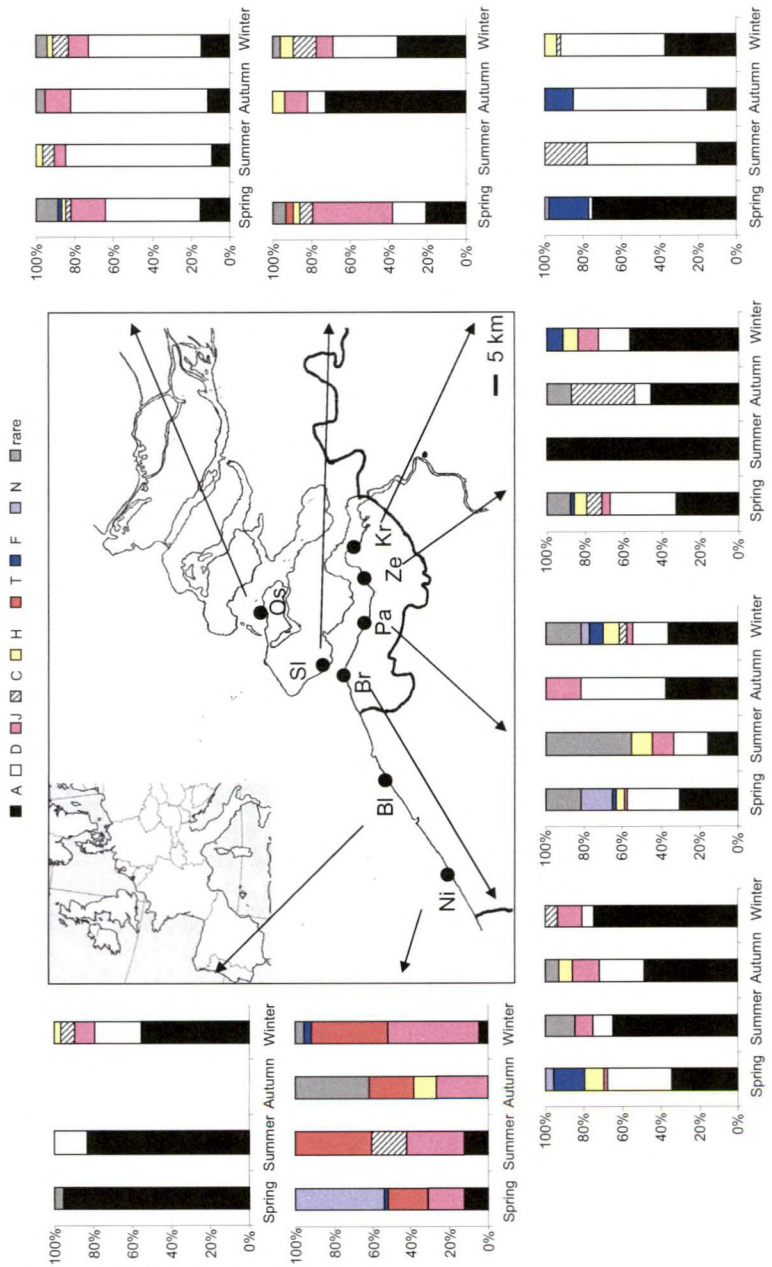

118963

---

CHAPTER IV

SPATIOTEMPORAL ANALYSIS OF POPULATION GENETIC  
STRUCTURE IN *GEOMONHYSTERA DISJUNCTA* (NEMATODA,  
MONHYSTERIDA) REVEALS HIGH LEVELS OF MOLECULAR  
DIVERSITY

---

Published as:

Derycke S , Backeljau T , Vlaeminck C , Vierstraete A , Vanfleteren J , Vincx M ,  
Moens T (2007a) Spatiotemporal analysis of population genetic structure in  
*Geomonhystera disjuncta* (Nematoda, Monhysterida) reveals high levels of  
molecular diversity. **Mar Biol**, DOI: 10.1007/s00227-007-0609-0.

### ABSTRACT

Species identification in the phylum Nematoda is complicated due to the paucity of easily obtainable diagnostic morphological features. Furthermore, the cosmopolitan distribution of several species despite low dispersal abilities makes cryptic diversity potentially substantial within this phylum. We conducted a population genetic survey in the marine nematode *Geomonhystera disjuncta* in Belgium and The Netherlands in two seasons. The mitochondrial cytochrome oxidase c subunit 1 (COI) gene was screened with the single-strand conformation polymorphism method in 759 individuals. The 43 haplotypes were grouped into five lineages, with low divergences within (< 3%) and high divergences between lineages (> 14%). Analysis of the nuclear ITS region yielded concordant tree topologies, indicating the presence of five cryptic taxa within *G. disjuncta*. Analysis of Molecular Variance (AMOVA) illustrated a significant structuring in all lineages and temporal fluctuations in haplotype frequencies within and between locations. Metapopulation dynamics and/or priority effects best explained this structuring. Finally, our data indicate that the COI gene may be useful for DNA barcoding purposes.

## INTRODUCTION

Nematodes are one of the most abundant and diverse metazoan phyla in terms of species richness (Lambshhead 2004), comprising both parasitic and free-living species. Only a small fraction of the total predicted nematode diversity is currently described (e.g. Hugot et al. 2001, Blaxter et al. 2005), mainly due to their small body size (~ 1 mm). This complicates species identification because important morphological features may be situated at scales that are beyond the resolution of light microscopy (Coomans 2002, De Ley et al. 2005, Markmann & Tautz 2005). In addition, many nematode species have a worldwide distribution, despite an endobenthic life style, a lack of pelagic larvae and a limited dispersal capacity. Obviously, the combined effects of morphological limitations in species identification and a cosmopolitan distribution despite limited dispersal abilities make cryptic diversity potentially substantial within the Nematoda.

Population genetic surveys provide important information on genetic diversity within and connectivity between populations and frequently uncover cryptic taxa (Schizas et al. 1999, Knowlton 2000, Rocha Olivares et al. 2001, Govindarajan et al. 2005). In this way, they have challenged the longstanding view of low species diversity and broad-scale homogeneity in the marine environment (Caudill & Bucklin 2004, Ovenden et al. 2004). Within the Nematoda, population genetic studies have mainly been restricted to parasitic species (e.g. Blouin et al. 1995, Hu et al. 2002, Høglund et al. 2004, Picard et al. 2004 but see Sivasundar & Hey 2005). The single free-living marine species hitherto studied, *Pellioiditis marina*, showed restricted gene flow and cryptic diversity even on a very local scale (40 km), which was at variance with expectations based on this species' potentially substantial passive dispersal capacity and its life-history characteristics (Derycke et al. 2005, 2006). In addition, cytochrome oxidase c subunit I (COI) and ribosomal intergenic transcribed spacer (ITS) data unravelled four cryptic taxa within *P. marina*, with sequence divergences between them ranging from 5.8 - 10.6 % for COI and 3.3 - 21.1 % for ITS. These high divergences raise questions on the modes of speciation and on the generality of such cryptic diversity in other marine nematodes occurring in areas with supposedly well-described nematode communities. Indeed, recent diversity assessments in the marine environment based on DNA barcoding indicate that cryptic diversity is far more common than initially thought (Blaxter 2004).

The major objective of the present study is to analyse the population genetic structure of a second marine nematode species, *Geomonhystera disjuncta* (Bastian, 1865)<sup>19</sup> (Monhysteridae), as a first step towards inferring more general conclusions on population genetic structuring and cryptic diversity in free-living marine nematodes. The genus *Geomonhystera* Andr ssy, 1981 differs from the other monhysterid genera in the position of the vulva, which is typically situated far back, at more than 75 % of the body length (Andr ssy 1981). The genus contains 15 valid species, seven of which are marine (Jacobs 1987). *G. disjuncta* can be distinguished from the other six by differences in body size, position of the vulva, shape and length of the tail, and shape and number of eggs (De Coninck & Schuurmans Stekhoven 1933, Hopper 1969). The sampling area – which is well-investigated with respect to its nematode communities (e.g. Vincx 1990, Vincx et al. 1990) – and design were similar to those for *P. marina* (Derycke et al. 2005), except that we sampled in two different seasons. *G. disjuncta* occurs sympatrically with *P. marina* and also has a short generation time (ca. 8 days) with a high reproductive output (ca 200-500 eggs female<sup>-1</sup>) (Vranken et al. 1988). However, *G. disjuncta* differs from *P. marina* in several other aspects of its life-history characteristics: 1) it does not produce Dauerlarvae (i.e. metabolically less active larvae that can survive unfavourable conditions) (Bongers & Bongers 1998); 2) it occurs under a broader range of food (bacteria) availability (Vranken et al. 1988, Moens & Vincx 2000); and 3) it is not solely found on macroalgal detritus, but also on other organic materials (Mokievsky et al. 2005) and in marine sediments (Heip et al. 1985, Vranken 1987).

In view of these characteristics, two main aims were targeted in this study: 1) to investigate the population genetic structure of *G. disjuncta* and compare it with that of *P. marina*, a sympatrically occurring nematode species with different life-history characteristics; and 2) to assess intraspecific diversity and possible cryptic taxa in *G. disjuncta* by using different molecular markers and phylogenetic analyses.

---

<sup>19</sup> See General Introduction, p 9: *Geomonhystera disjuncta* is recently renamed to *Halomonhystera disjuncta*. *Pellioditis* is now considered a subgenus of *Rhabditis*.



## MATERIAL AND METHODS

### SAMPLE COLLECTION AND PROCESSING

We sampled *Geomonhystera disjuncta* at eight locations along the Belgian coast and southwestern part of The Netherlands (Fig. 4.1). Nematodes were collected from *Fucus sp.* fragments at four estuarine locations in the Westerschelde (Br, Pa, Ze and Kr), two coastal locations in Belgium (Ni and Bl), and one location in the Oosterschelde (Os, a coastal lagoon). In addition, we collected *G. disjuncta* from *Ulva sp.* and *Enteromorpha sp.* in Lake Grevelingen (Gr), as *Fucus sp.* was not found there. For a more detailed description of the locations and collection methods we refer to Derycke et al. (2006). This geographical sampling scheme was conducted in April 2003 and repeated in January 2004. Additional samples were collected in Br in summer 2003, and in Os and Gr in autumn 2003.

We incubated randomly collected fragments of algal thalli on agar-slants for a maximum of five days. This period is shorter than the shortest generation time of *G. disjuncta* (Vranken et al. 1988, Moens unpubl.) under optimal conditions, and hence ensured that we sampled the natural population rather than individuals bred in the laboratory. Adult *G. disjuncta* were identified alive under a dissecting microscope using morphological and behavioral characteristics, hand-picked and transferred to sterile water. Because of its small body size (less than 1.5 mm), and because of limits to the diagnostic power of the characteristics that can be observed on live individuals, we created an identification backup as follows: 80 - 100 individuals from each location were transferred into one embryo dish containing sterile artificial seawater with a salinity of 25; 50 of these were randomly picked out and preserved on acetone (ca. 70 - 95 %) for molecular analysis. The remaining individuals were mounted on glycerine slides (Vincx 1996), and subsequently identified at high magnification under a microscope (Leica DLMB; magnification 100X) using species descriptions (De Coninck & Schuurmans Stekhoven 1933, Gerlach 1965, Hopper 1969, Warwick et al. 1998). In addition, we performed morphometric analysis on a subset of individuals belonging to different mitochondrial lineages (throughout the manuscript, we use the term 'lineage' to refer to the highly divergent haplotype groups shown in Fig. 4.4): 10 randomly chosen individuals (five males and five females) from each of

**Fig. 4.1:** *Geomonhystera disjuncta*. Distribution of the five lineages (Gd1, Gd2, Gd3, Gd4 and Gd5) among the eight sampled locations in Belgium and The Netherlands. The stacked column diagrams show the percentage of each lineage during spring (sp), summer (su), and autumn (au) 2003 and winter 2004 (wi) in each location. The summer and autumn campaign were only successful for 1 and 2 locations respectively. No *G. disjuncta* specimens were found in the upstream Westerschelde locations (Ze and Kr) nor in Lake Grevelingen (Gr) in the summer campaign. All other sampling gaps are due to a very low PCR success rate. Ni = Nieuwpoort; Bl = Blankenberge; Br = Breskens; Pa = Paulina; Ze = Zeedorp; Kr = Kruispolderhaven; Os = Oosterschelde; Gr = Grevelingen.

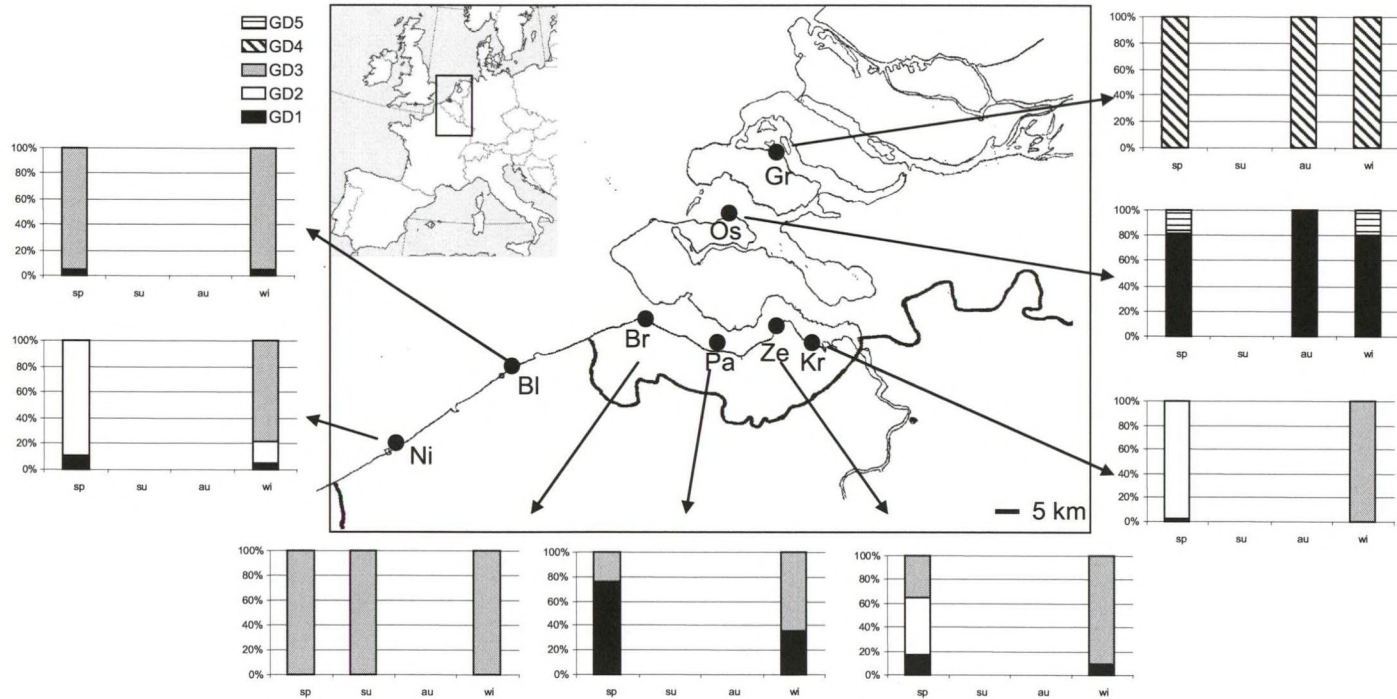

four localities containing a single lineage (Gr and Br) or nearly so (i.e.  $\geq 98\%$  of all individuals belong to the same lineage, Kr and Os) were processed<sup>20</sup>. Glycerine slides were mounted under a Leitz Dialux 20 microscope (magnification 10X25X and 10X50X), and a Sanyo CCD video camera and the Quantimet 500 software were used for measurements. We measured total body length (L) and maximum body width (mbd). Additional parameters were anal body diameter (abd) and length of spicules (spic) for males, and distance between vulva-mouth (v) and between vulva-anus in females. Three ratios were calculated: L/mbd, spic/abd, %V. This procedure enabled us to exclude misidentifications during the first step of the nematode isolation method.

#### MOLECULAR ANALYSIS

We screened approximately 40 individuals from each location and time for variation in the mitochondrial DNA COI gene, except for Ni in January 2004, where  $n = 23$ . For a detailed description of the DNA extraction protocol we refer to Derycke et al. (2005). After DNA preparation, 422 bp of the COI gene were amplified with the following degenerated primers: JB2 (5'- ATGTTTTGATTTTACCWGCWTTYGG TGT-3') and JB5GED (5'-AGCACCTAAACTTAAAACATARTGRAARTG - 3')<sup>21</sup>. All populations collected in April were analysed with this primer set. However, PCR-amplification of individuals from Os and Gr collected in autumn 2003 and winter 2004 was problematic. Therefore, we designed a new degenerated reverse primer (JB8: 5'-CCCCTCTAGTCTWCTATTTCTTAATAC-3') located 29 bp upstream of the 30 bp long JB5GED primer, yielding a fragment of 363 bp. PCR conditions were as in Derycke et al. (2005), except for the annealing temperature, which was 50°C for both primersets. Variation in the COI gene was detected using the Single Strand Conformation Polymorphism (SSCP) method as described in Derycke et al. (2005). We sequenced all PCR-products with different SSCP-profiles with the aforementioned primers (accession numbers AM180357 – AM180399), as were 10 % of all individuals in every location to confirm the agreement between SSCP-band

---

<sup>20</sup> Morphological and molecular data were collected from different specimens. The link between molecular lineages and morphometric data was established by analysing specimens from localities where only one (or nearly so) molecular lineage was encountered.

<sup>21</sup> The remaining DNA was stored at -80°C. In this way, multiple loci could be amplified from the same individual.

mobility and sequence variation. PCR products were purified and sequenced as described in Derycke et al. (2005).

COI haplotypes were grouped into five highly divergent lineages (Fig. 4.4). Three individuals of each lineage, representing the three most abundant haplotypes of that lineage, were sequenced for the nuclear ribosomal ITS1 - 5.8S - ITS2 region. In addition, we sequenced two individuals containing haplotype G61. The ITS region was amplified and sequenced as in Derycke et al. (2005) (accession numbers AM180400 – AM180415).

### DATA ANALYSIS

#### Statistical analysis of morphometric data.

The primary objective of the measurements was to ensure that all specimens were *G. disjuncta*. However, the same data allow a first exploration of whether morphological differences between the genetic lineages exist. The data met the assumptions of normality and homoscedasticity, and analysis of variance (ANOVA) and Tukey's HSD pairwise comparisons (Statistica 6.0, Statsoft 2001) were used to assess whether morphological differences occurred between the mitochondrial DNA lineages.

#### COI variation and phylogenetic analysis.

COI sequences were aligned in ClustalX v.1.74 (Thompson et al. 1997). The number of pairwise differences between all haplotypes was calculated in Mega 3.0 (Kumar et al. 2004). A statistical parsimony network was constructed in TCS v.1.18 (Clement et al. 2000) to explore the evolutionary relationships among haplotypes. This yielded several unconnected subnetworks, indicating that some haplotypes were too divergent to establish a reliable parsimonious connection (i.e. 95 %). The aligned sequences were used for further phylogenetic analysis in PAUP\* 4.0 beta 10 (Swofford 1998).

The ITS alignment was constructed in ClustalX v 1.74 (Thompson et al. 1997) with default gap costs. Several indels were observed, and ambiguous sites were improved manually in Genedoc 2.6 (Nicholas & Nicholas 1997). Modeltest 3.7 (Posada & Crandall 1998) and the Akaike Information Criterion (Posada & Buckley 2004) were used to determine the maximum likelihood settings for constructing the

neighbour - joining (NJ) tree: the HKY+I+G model (Hasegawa et al. 1985) gave the best fit for the COI fragment and for the simultaneous analysis of COI and ITS. A permutation homology test (Mickevich & Farris 1981) was performed using PAUP\* to assess the degree of phylogenetic incongruence between COI and ITS data. Parsimony (MP) trees were obtained using a random stepwise addition of sequences and a tree-bisection-reconnection branch swapping algorithm (with 10000 rearrangements). Bootstrap values for MP and NJ were inferred from 1000 replicates. In addition, a Bayesian analysis was performed in MrBayes v 3.1.2 (Huelsenbeck & Ronquist 2005). Four independent Markov chains were run for 500 000 generations, with a tree saved every 10th generation. The first 10 000 trees were discarded as burn-in. MrModeltest 2.2 (Nylander 2004) was used to determine the best model for Bayesian analysis of our data: the HKY+I+G model best fitted the COI fragment, while the HKY+I model was chosen for the ITS data.

#### Population genetic structure (COI).

Intra-population diversity was assessed by calculating haplotype - ( $h$ , Nei 1987) and nucleotide diversity ( $\pi$ , Nei 1987) in Arlequin v.2.0 (Schneider et al. 2000). Both parameters were tested for significant differences between mitochondrial lineages and between locations within lineages by a non-parametric Kruskal–Wallis test. Pairwise a posteriori comparisons were performed with the Mann–Whitney U test, corrected by the sequential Bonferroni method (Rice 1989). The statistical tests were performed with the Statistica 6.0 program (Statsoft 2001).

Heterogeneity between populations was investigated with an analysis of molecular variance (AMOVA) as implemented in Arlequin v 2.0. The total dataset was divided such that genetic structure was analysed for each lineage and at each time point separately by a single-level AMOVA (i.e. without nesting). This analysis could not be performed for Gd4 and Gd5, as these lineages were restricted to a single locality. The isolation-by-distance model was tested with IBD 1.5 (Bohonak 2002) for those lineages occurring in several locations at both time points (Gd1 and Gd3). Geographic distance between populations was measured as the shortest continuous water surface distance, and was compared with Cavalli-Sforza & Edwards' (1967) chord distances (DCE) between populations.

### Temporal analysis of the population genetic structure.

No temporal analysis of the genetic structure was performed for lineage Gd2 as it only occurred at one location (Ni) in January 2004 (Fig. 4.1). Stability of the observed genetic patterns over time in lineages Gd1 and Gd3 was tested in two different ways. First, significant differences in the level of spatial genetic variation ( $F_{st}$ ) for Gd1 and Gd3 in 2003 and 2004 were tested with a randomisation procedure (10,000 permutations) as implemented in Fstat v 2.9.3 (Goudet 2001). Secondly, Cavalli-Sforza & Edwards' (1967) chord distances (DCE) for Gd1 and Gd3 were calculated between populations within each year using Phylip 3.6 (Felsenstein 2004). This yielded two matrices (spring 2003 and winter 2004) with genetic distances for each lineage. These matrices were compared by a Mantel test with 1000 permutations as implemented in TFPGA 1.3 (Miller 1997). A significant test result indicates that genetic distances between localities are correlated and thus that the degree of genetic structure remains stable over time. Finally, spatial and temporal differentiation were compared in a two-level AMOVA (i.e. temporal samples were pooled within localities) for both lineages. Temporal changes in haplotype frequencies within every locality were investigated for all five lineages separately using a single-level AMOVA.

## RESULTS

## MORPHOMETRIC DATA

Male body length varied between 0.84 and 1.40 mm, while female body length ranged between 0.87 and 1.33 mm. No significant differences were observed between lineages ( $p = 0.35$  for males and  $p = 0.52$  for females). Maximum body width in females ranged from 31.86 – 49.15  $\mu\text{m}$  and from 26.8 – 42.1  $\mu\text{m}$  in males, which resulted in lower values of the female L/mbd ratio (Fig. 4.2a). Total body width was similar for all lineages ( $p = 0.91$  for males and  $p = 0.45$  for females). No significant differences in measurements were found among females when allocated to genetic lineages: e.g. %V ranged from 84.35 % to 93.22 % ( $p = 0.1$ ). Although spicule length (ranging from 32.35 – 41.26  $\mu\text{m}$ ) and abd (ranging from 21.09 – 29.87) were not significantly different between lineages ( $p = 0.29$  and  $p = 0.11$  respectively), the spic/abd ratio was different between males from lineages Gd2 and Gd3 ( $p = 0.01$ , Fig. 4.2b).

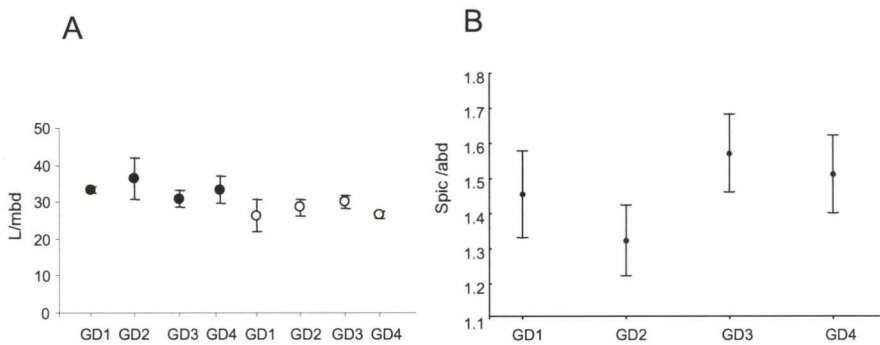
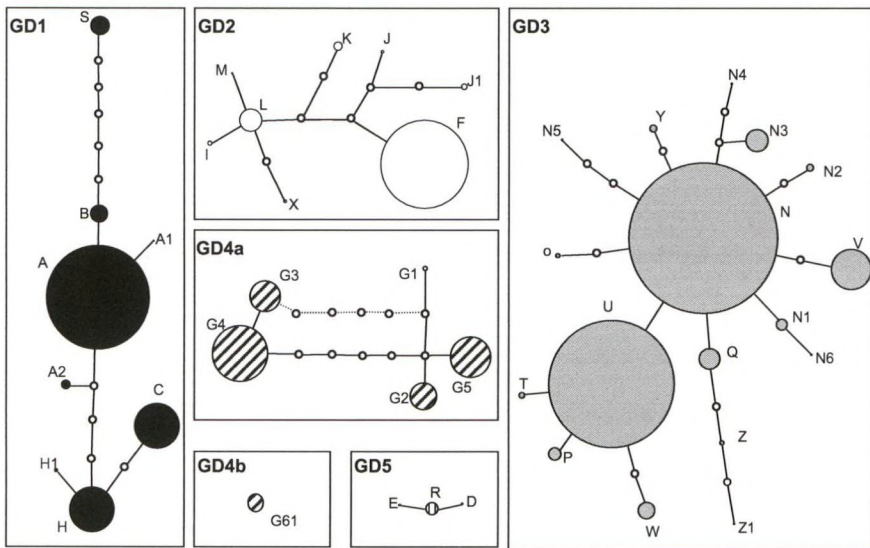

**Fig. 4.2:** *Geomonhystera disjuncta*. Morphometric data of specimens belonging to lineages Gd1, Gd2, Gd3 and Gd4, respectively. A: L/mbd ratio of males (black dots) and females (white dots); B: spic/abd ratio of males. Each dot represents the average of measurements in five specimens, and error bars represent standard deviations. Current effect:  $F(3, 16) = 4.61, p = 0.017$ .

## COI VARIATION

A total of 311bp of the COI gene was screened in 759 individuals of *G. disjuncta* (Table 4.1). This fragment contained 117 variable positions, 112 of which were parsimony informative and five of which were singletons. This yielded 43 different haplotypes, with divergences among haplotypes ranging from 0.32 –

25.72 % (1 – 80 substitutions). This corresponded with 0 – 6 amino acid changes. No indels occurred in the alignment. The parsimony network contained six unconnected subnetworks, indicating that high levels of divergence were present between these haplotype groups (the distinction between Gd1, 2, 3, 4a, 4b and 5 is based on the phylogenetic analysis (see next section); Fig. 4.3). For clarity, these haplotype groups will be referred to as lineages in what follows. The number of substitutions between haplotypes of a particular lineage was low and ranged from 0.32 – 2.56 % (but see end of next section), while high divergences were observed between haplotypes of different lineages (13.8 – 25.7 %).



**Fig. 4.3:** *Geomonhystera disjuncta*. Statistical parsimony network among 42 COI haplotypes (haplotype D1 is missing due to incomplete sequence information). Shadings are in agreement with the lineages presented in Fig. 4.1. Circles are proportional to the absolute frequency of haplotypes in the total dataset. Small white circles are missing haplotypes.

Lineage Gd3 was highly diverse and contained 17 haplotypes, which are connected to each other via a starlike pattern. Haplotypes N and U occurred in high frequency while most other haplotypes were rare (Fig. 4.3). In fact, these two haplotypes were the most abundant and widespread haplotypes: they were present in each locality, except for Gr and Os. Gd1 and Gd4a contained few rare haplotypes and are characterized by many missing haplotypes. Gd4b consisted of a single haplotype (G61), and this haplotype contained four of the five observed singletons. Like all haplotypes of Gd4a, haplotype G61 only occurred in Gr. A starlike pattern was also present in haplotype group Gd2. Interestingly, the most frequently observed





haplotype (F) did not occur in the center of this pattern. Finally, three rare haplotypes formed haplotype group Gd5, which was only observed in Os.

Unlike the parsimony network, the number of amino acid substitutions gave additional information on the relationship between the haplotype groups: no amino acid substitutions occurred between haplotype groups Gd1, Gd4a and Gd4b and between Gd2 and Gd5, while four – five amino acid changes occurred between groups Gd1+Gd4a+Gd4b, Gd2+Gd5 and Gd3. The number of unique fixed base differences (i.e. the number of bases at which a ‘species’ is different from all others, Kliman & Hey 1993) for the six groups ranged from 3 – 18.

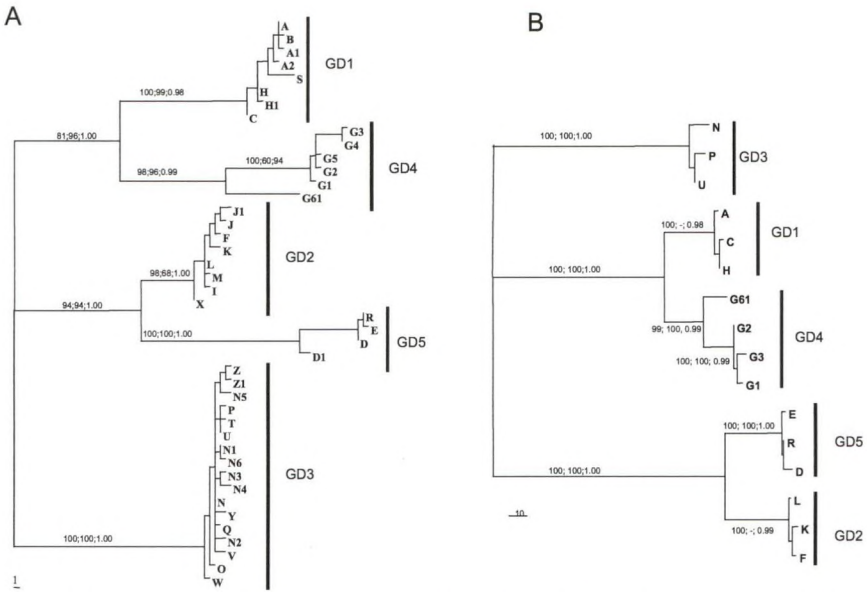

**Fig. 4.4:** *Geomonhystera disjuncta*. Maximum parsimony tree of COI haplotypes (A) and COI and ITS-spacer data combined (B). Five lineages (Gd1-5) are indicated with black bars. Bootstrap values of MP and NJ, followed by Bayesian probabilities are indicated above branches.

## PHYLOGENETIC ANALYSIS

MP, NJ and Bayesian analysis of the 43 COI haplotypes yielded highly concordant tree topologies (Fig. 4.4a). Five haplotype groups with high bootstrap support and deep divergences were distinguished and were identical to five of the six subnetworks identified in the parsimony network (Fig. 4.3). Haplotype G61 (Gd4b) clearly was more related to the haplotypes of subnet Gd4a than to all other haplotypes.

The final ITS alignment was 749 bp long and contained 211 variable positions, 201 of which were parsimony informative. Up to four long indels (12 – 36 bp) were observed in the ITS1 alignment (338 bp), whereas four small indels (2 – 9 bp) occurred in the ITS2 alignment (247 bp). The 5.8S region (165bp) contained 0 – 25 substitutions, but no indels were observed. The partition homogeneity test suggested that COI and ITS did not possess significantly conflicting phylogenetic signals ( $p = 0.89$ ). Both markers were therefore combined for further phylogenetic analysis and gave strong support for all five lineages (Fig. 4.4b). The total length of the ITS spacer region varied between the three major clades from 614 to 733 bp, while only few indel events were observed within each major clade (0 – 2 bp). Divergences within the five lineages varied between 0 – 2 %, while up to 22.9 % variation was present between lineages (Table 4.2). Interestingly, individuals containing the mitochondrial haplotype G61 had identical ITS sequences as individuals of lineage Gd4. We therefore divided all 759 individuals into five distinct lineages (taxa) (Gd1-5), and treated haplotype G61 as a long-branch within lineage Gd4. In addition, this subdivision is based on extrinsic geographical data (see next section). Adding G61 to Gd4 increased the intralinesage divergence of the COI fragment to 10.9 %.

	GD1	GD2	GD3	GD4	GD5
GD1		17.6 - 23.2	23.6 - 25.4	17.36 - 19.3	22.1 - 23.2
GD2	19.8 - 21.1		20.6 - 23.2	21.2 - 25.7	13.8 - 16.1
GD3	19.5 - 21.1	22.4 - 24.1		21.9 - 25.4	24.4 - 25.7
GD4	1.0 - 1.2	19.5 - 19.6	18.9 - 20.8		22.8 - 25.1
GD5	20.0 - 20.3	3.4 - 3.7	22.9 - 24.7	19.8 - 20.0	

**Table 4.2.** *Geomonhystera disjuncta*. Divergence ranges (%) among the five lineages (Gd1-5). Above diagonal are values for the COI fragment, below diagonal are values for the ITS spacer region.

### *DISTRIBUTION OF THE FIVE GD LINEAGES*

Fig. 4.1 shows the relative abundances and geographical distribution of each lineage at two (or three) sampling events. Several lineages co-occurred at different localities, but two were clearly restricted to one locality: Gd4 was only found in Gr and Gd5 in Os. Fig. 4.1 also indicates that Gd1 rather than Gd5 was dominant in Os. In fact, only 2 % of all individuals belonged to Gd5. In contrast, 43 % of all individuals belonged to Gd3.

Temporal fluctuations in relative abundances were especially prominent in lineage Gd2: more than 80 % of the individuals from Ni and Kr and more than 40 % of the specimens from Ze belonged to this group in April 2003. However, these abundances declined and even disappeared in January 2004, concomitantly with an increase in the relative abundance of lineage Gd3. Although Gd3 was highly abundant in the estuarine and coastal locations, it was not found in Os and Gr.

### *POPULATION GENETIC STRUCTURE*

Values of intra-population diversity parameters for each lineage separately are summarized in Table 4.1. Haplotype diversity ( $h$ ) for each lineage was high and similar in all locations (Kruskal–Wallis:  $p > 0.2$ ). Nucleotide diversity ( $\pi$ ) was also similar among locations (Kruskal–Wallis:  $p > 0.2$ ), but significant differences were observed when  $\pi$  values were compared between lineages ( $p = 0.003$ ). These differences were situated between lineage Gd1 and Gd3 (Mann-Whitney U and corrected with Bonferroni:  $p = 0.001$ ). Highest nucleotide diversity ( $\pi$ ) was observed in populations of Gd4, but this was not significant after Bonferroni correction.

All sampled locations can freely exchange individuals, except for Os and Lake Grevelingen, which are isolated from the North Sea by man made barriers. Contrary to Lake Grevelingen, the Os population is not completely closed from the North Sea due to the presence of the storm surge barrier, which is open for several periods in a year.

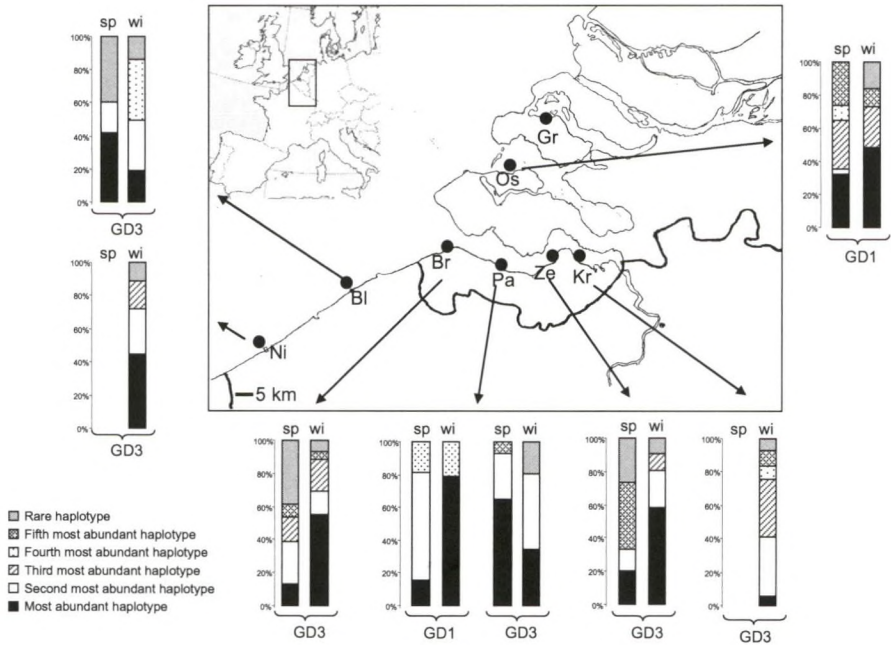

**Fig. 4.5:** *Geomonhystera disjuncta*. Lineage Gd1 and Gd3. Distribution of the five most abundant haplotypes of each lineage in spring 2003 (sp) and winter 2004 (wi) among the eight locations. Frequencies of haplotypes were summarized across the two seasons and all locations. Haplotypes A, H, C, S and B were the most abundant haplotypes for lineage GD1, respectively, and haplotypes N, U, V, N3 and Q for lineage GD3, respectively. All other haplotypes are pooled in a sixth class ('rare haplotypes'). Sample abbreviations are as in Fig. 4.1.

For Gd3, a highly significant structuring was observed even within the Westerschelde estuary, in April 2003 ( $F_{st} = 0.15$ ,  $p < 0.0001$ ) as well as in January 2004 ( $F_{st} = 0.13$ ,  $p < 0.0001$ ). In contrast, lineage Gd2 exhibited no significant genetic substructuring (Table 4.3). However, omitting Os did produce a low structuring among the other three locations ( $F_{st} = 0.056$ ,  $p = 0.01$ ). No correlation was found between DCE genetic distances and geographic distances ( $p > 0.5$  for Gd1;  $p > 0.2$  for Gd3), indicating that the observed genetic structure is not the result of an isolation-by-distance model.

	GD1			GD2			GD3		
	%	Fst	p-value	%	Fst	p-value	%	Fst	p-value
<b>Spring 2003</b>									
among populations	25.07	0.25	***	4.24	0.04	ns	13.20	0.13	***
within populations	74.93			95.76			86.80		
<b>Winter 2004</b>									
among populations	16.50	0.16	***				11.42	0.11	***
within populations	83.50						88.58		

**Table 4.3.** *Geomonhystera disjuncta*. Single-level AMOVA results for lineages Gd1, Gd2 and Gd3 in spring 2003 and winter 2004. (ns) not significant; (\*\*\*)  $p < 0.0001$ .

#### TEMPORAL ANALYSIS OF POPULATION GENETIC STRUCTURE

The level of variation between populations (Fst values) did not change significantly over time (Fstat:  $p = 0.56$  for Gd1,  $p = 0.65$  for Gd3), but changes in the genetic composition among populations did occur (Manteltest, Gd1:  $r = 0.44$  and  $p = 0.1$ ; Gd3:  $r = -0.12$  and  $p = 0.73$ ). This change in haplotype composition is illustrated in Fig. 4.5 for both lineages. Because the frequency of lineage Gd1 was low in most locations (Table 4.1), only haplotype composition in Pa and Os are presented. Temporal differentiation was large and highly significant in Pa (Fst = 0.45), while only small differences were found in Os (Fst = 0.03). For Gd3, temporal differences were high in Ze (Fst = 0.2) and Bl (Fst = 0.11). No significant temporal changes were observed in Pa.

In addition, significant temporal fluctuations in haplotype frequencies were prominent for lineage Gd4 in Gr (Fst = 0.21,  $p < 0.0001$ ), and for lineage Gd2 in Ni (Fst = 0.51,  $p < 0.0001$ ). Temporal differentiation for lineage Gd5 in Os was high but only just significant (Fst = 0.15,  $p = 0.03$ ).

## DISCUSSION

### MOLECULAR DIVERSITY IN NEMATODES

All our morphometric measurements fall within the range of variation observed in *G. disjuncta* (De Coninck & Schuurmans Stekhoven 1933, Hopper 1696) and several females contained eggs with embryos, a feature that within the genus only has been observed in *G. disjuncta* and *G. chitwoodi* (Chitwood, 1951). However, both species differ in the position of the vulva, which is situated much more posteriorly in *G. disjuncta*. Consequently, all specimens analysed in this study are *G. disjuncta*. Our morphometric data did not detect much morphological differentiation between lineages, but a more comprehensive study is clearly required to infer whether the genetic lineages are also accompanied by morphological differences.

Both COI and ITS data reveal high levels of molecular diversity within *G. disjuncta*: five distinct lineages were found on a small spatial scale, with low levels of divergence within lineages (< 3 %, except for Gd4), and high levels of variation between lineages (> 13 %). Intraspecific divergences for COI in parasitic nematode species are commonly lower than 5 % (Blouin 2002, Hu et al. 2002, Otranto et al. 2005), while congeneric species typically show divergences in the range of 10-20 % (Blouin 2002). However, a straightforward delineation of species based solely on genetic divergence data is problematic (Ferguson 2002): high levels of intraspecific divergence have been found in other nematode species, e.g. 8.4 % in *Oesophagostomum bifurcum* (de Gruyter et al. 2002) and 8.6 % in *Ancylostoma caninum* (Hu et al. 2002), while lower than 10 % divergence has been recorded between congeneric species of *Pellioiditis* (Derycke et al. 2005) and *Ancylostoma* (Hu et al. 2002). Consequently, multiple molecular markers are needed for taxonomic interpretations of deeply diverged lineages within the Nematoda (Nadler 2002).

The ITS data reveal the same five lineages, but divergence values between them are much lower (< 4 %) than in the mitochondrial COI gene (> 13 %, see Table 4.2). Evolution of the ITS region is influenced by factors such as functional constraint, unequal crossing over and gene conversion, which all reduce intraspecific variation (Hillis & Dixon 1991). In addition, mitochondrial genes have higher mutation rates and a fourfold smaller effective size and consequently evolve more rapidly than the nuclear genes (Avice 2000).

Significant population structuring was observed in all lineages of *G. disjuncta* occurring at more than one location, even within the Westerschelde. This suggests restricted gene flow and limited effective dispersal between populations. However, observations of rafting (e.g. on algae, Derycke pers observ, and on sediment films, Faust & Gullledge 1996) indicate that dispersal in nematodes inhabiting algal substrata can be substantial (Ullberg 2004). Hence, it is questionable whether the observed genetic structure of the *G. disjuncta* lineages can be due to the mere lack of gene flow, as the exchange of only one migrant (assuming that selection and genetic drift are low, Slatkin 1987) could be sufficient to prevent the accumulation of large genetic differences between populations. In spite of differences in life-history characteristics and habitat preferences, genetic structuring was similar in the most abundant lineage of the *P. marina* and *G. disjuncta* complexes:  $F_{st}$  values in April 2003 and Winter 2004 were 0.09 and 0.11, respectively, for PmI, and 0.13 and 0.11, respectively, for Gd3.

Our data also show that the observed genetic structure changes over time and that temporal fluctuations in haplotype frequencies are substantial within the *G. disjuncta* complex. *G. disjuncta* is a strong colonizer, which reaches its maximal abundances on decomposing algal thalli later and maintains high densities longer than *P. marina* (Bongers & Bongers 1998, Mokievsky et al. 2005, Derycke, unpubl. data). Hence, two alternative hypotheses for the differences in haplotype frequencies are plausible. First, the temporal differences can be caused by colonisation – extinction dynamics (De Meester et al. 2002, Derycke et al. 2006). Considering the ephemeral nature and patchy distribution of algal deposits, metapopulation dynamics are indeed likely in *G. disjuncta*. However, *G. disjuncta* is also frequently observed in the sediment, and consequently extinction of *G. disjuncta* when algae are completely decomposed is unlikely. Another explanation is that *G. disjuncta* colonizes the algae and subsequently exhibits priority effects, i.e. the first colonising individuals have such a strong population development that they reduce the settlement of new specimens. Depending on which individuals arrive at the patches, differences in haplotype composition can occur. Such priority effects have been observed in lentic habitats (Boileau et al. 1992) and recently also in a field experiment with *P. marina* (Derycke et al. 2007c).



## TAXONOMY IN MARINE NEMATODES

Both COI and ITS data reveal high levels of intraspecific diversity within *G. disjuncta*. The concordance among COI and ITS data suggests cyto-nuclear disequilibrium, which is caused by either reproductive isolation, epistatic effects across genomes or drift (Asmussen et al. 1987). Even separately (i.e. ITS1, ITS2 and to a lesser extent 5.8S, data not shown), the nuclear regions show the same phylogenetic pattern as the mitochondrial gene, hence the disequilibrium is most likely caused by reproductive isolation (Latta et al. 2001). In addition, the number of unique fixed differences between lineages for both molecular markers confirms that all lineages have distinct gene pools, even though they co-occur at most locations. Both arguments suggest that the lineages are in fact 'biological species'. As all lineages are monophyletic for both molecular markers, they are also phylogenetic and genealogical species (Rocha-Olivares et al. 2001). Lineage Gd3 contains the highest number of haplotypes and is the most abundant and widespread lineage. It has, however, the lowest nucleotide diversity of all lineages, indicating that haplotypes have not accumulated many mutations. Several unique haplotypes are present and connected via a star-like pattern, which suggests a recent radiation of this lineage (Rogers & Harpending 1992).

Two pairs of sistertaxa are present (Gd1 and Gd4, Gd2 and Gd5), with Gd4 and Gd5 exclusively found in Gr and Os, respectively. As elaborately described and discussed in Derycke et al. (2006), allopatric speciation is unlikely since the geographical separation happened too recently for the lineages to have accumulated such high divergences. However, Ullberg (2004) pointed out that restricted gene flow and the direct developing larvae in nematodes can lead to an increased speciation rate in this phylum. Next to the presence of geographical barriers in both Os and Gr, they also contain different environmental characteristics and substrata (Derycke et al., 2006). Clearly, additional sampling in Gr and Os and on a broader geographical scale is needed to elucidate the modes of speciation.

The cryptic diversity observed in *G. disjuncta* as well as in *P. marina* highlights the difficulties of a morphology-based identification system for nematodes. In view of the effort required to find morphological diagnostic features, DNA-barcoding may provide a first step towards a more efficient search (De Ley et al. 2005). The COI gene has been designated as a good marker for barcoding life on earth

(Hebert et al. 2003a,b), and at first sight, the results of the present and earlier work (Derycke et al. 2005, 2006) could be considered as an indication that COI would be applicable for nematode identification, as it recognizes both cryptic and morphological taxa. Moreover, a huge part of the nematode diversity is currently unknown, and therefore a good barcoding marker for the phylum Nematoda preferably should also be phylogenetically informative so that new species can be discovered. Our COI sequences were only moderately phylogenetically informative, and some haplotypes remained unresolved (e.g. haplotype G61, or the Z haplotypes in *P. marina*, Derycke et al. 2006), supporting the contention that more than one genomic DNA sequence is required to distinguish closely related taxa by barcoding (Mallet & Willmott 2003, Tautz et al. 2003). One major drawback of the COI gene is its difficult amplification within the Nematoda (De Ley et al. 2005, Derycke et al. 2005, Bhadury et al. 2006). This and previous studies (Derycke et al. 2005, 2006) illustrate that more than one set of primers will be required for COI barcoding in this phylum. The ITS fragment, by contrast, was easily amplified in our species, but we feel that it is not a good universal identification tool for two reasons: 1) intra-individual variation was frequently observed, which reduces the sequencing signal and 2) a high amount of indel events are present within closely related cryptic taxa, rendering alignment between divergent taxa problematic. A promising alternative for DNA barcoding purposes in closely related nematode groups for which COI was not a good marker may be the SSU and LSU rDNA segments (Floyd et al. 2002, Blaxter 2004, De Ley et al. 2005), which also works well for *P. marina* (Chapter 6 and 9).

## CONCLUSION

Our studies in two nematode species (*G. disjuncta* and *P. marina*) indicate that cryptic diversity is likely to be substantial within free-living nematodes. This has important implications for biodiversity studies, and potentially renders a highly speciose phylum even more speciose than anticipated. Differences in life-history characteristics between *P. marina* and *G. disjuncta* did not result in clear differences in genetic patterns. Furthermore, colonisation dynamics in combination with persistent founder effects were the most plausible explanation for the observed genetic patterns within the *G. disjuncta* lineages. In addition, *P. marina* and *G. disjuncta* prevail on decomposing macroalgae in estuaries and coastal zones. Because of their life-history characteristics and 'epiphytic' rather than benthic microhabitats, they are not very typical marine nematodes. Therefore, extrapolation of our results to other marine nematodes requires some caution. Further research on a truly marine, less opportunistic species with different habitat preferences and life-history characteristics than *P. marina* and *G. disjuncta* will provide information on the generality of our results for the Nematoda. Such information is crucial to any assessment of marine nematode species diversity and to barcoding attempts for the phylum Nematoda in general.

## ACKNOWLEDGEMENTS

The authors thank Dr. T. Remerie for his suggestions and help in retrieving the data and Dr. M. Raes for his help with the morphological measurements of the specimens. S.D. acknowledges a grant from the Flemish Institute for the Promotion of Scientific-Technological Research (I.W.T.). T.M. is a postdoctoral fellow with the Flemish Fund for Scientific Research. Further financial support was obtained from Ghent University in BOF-projects 1205398 (GOA) and 01GZ0705 (GOA-BBSea).

118964

---

**CHAPTER V**

**INTEGRATIVE TAXONOMY DISCLOSES HIDDEN DIVERSITY IN**

**NEMATODES**

---

Submitted for publication in Biological Journal of the Linnean Society as:

Fonseca G, Derycke S, Moens T. Integrative taxonomy discloses nematode hidden diversity<sup>22</sup>

---

<sup>22</sup> Specimens, molecular data and molecular analyses in this chapter were provided by the second author.

**ABSTRACT**

Integrative taxonomy considers species boundaries from multiple, complementary perspectives, the main objective being to compare the observed data against the predictions of the methodologies used. In the present study we used four methods for delineating species boundaries within the cosmopolitan nematode species *Halomonhystera disjuncta* and *Rhabditis (Pellioiditis) marina*. First, phylogenetic relationships among molecular sequences from the mitochondrial cytochrome oxidase c subunit 1 gene (COI) and from the nuclear internal transcribed spacer region (ITS) were analysed. Subsequently, multivariate morphometric analysis was used to investigate whether concordant molecular lineages were also morphologically distinct. When morphological differences were found, typological taxonomy was performed in order to identify fixed or non-overlapping characters between lineages. Finally, interbreeding experiments were conducted between the two closest related lineages to investigate potential reproductive isolation. This integrative approach confirmed the presence of several species within each nominative species: molecular lineages were concordant across two independent loci, and were characterized by significant morphological divergence. The two lineages investigated in our study did not produce offspring. Our results highlight that classical taxonomy grossly underestimates species diversity within the phylum Nematoda.

## INTRODUCTION

Ever since it was shown that species may continue to diverge genetically in the absence of morphological differentiation, producing cryptic species (Avisé & Walker 1999, Hebert et al. 2004), taxonomy has become polarized between "classical" and molecular biologists (Blaxter & Floyd 2003, Lipscomb et al. 2003, Seberg et al. 2003, Sites & Marshall 2003, Tautz et al. 2003). The communication gap between the different disciplines contributing to a correct identification is an important and neglected problem in the so-called "taxonomy crisis" (Dayrat 2005). To solve this "crisis", species boundaries should be diagnosed with clear hypotheses on the criteria used in each methodology (Mallet 1995, Wu 2001, Sites & Marshall 2004). This is, however, complicated by the fact that different researchers emphasize different criteria, which in turn provide information on different phenomena associated with the separation of lineages. As an alternative to considering each method independently, authors have pointed to the "integrative taxonomy" approach where species boundaries are studied from multiple, complementary perspectives (Dayrat 2005, Will et al. 2005). Based on such a multidisciplinary approach, all species concepts are considered variations on the single theme of species as evolutionary lineages, where the main objective is to compare data against the predictions of the various methodologies used (de Queiroz 1998, 2005).

Integrative taxonomy has been efficiently introduced for some vertebrate (e.g. Bruna et al. 1996, Puerto et al. 2001, Wiens & Penkrot 2002, Malhotra & Thorpe 2004) and invertebrate taxa (Thomas & Hunt 1993, Baker et al. 2003, Parmakelis et al. 2003, Wahlberg et al. 2005), but has been much less applied to small-size metazoan groups like nematodes (Blaxter et al. 1998, De Ley et al. 1999, De Ley et al. 2005). Nematodes are the most abundant and one of the most diverse metazoan groups on Earth (Coomans 2002). However, the phylum suffers an enormous "taxonomic deficit" (the ratio of expected taxa vs named taxa) (Lambshhead 1993, Platt 1994), which hampers proper understanding of its evolutionary history and ecological importance. Taxonomical efforts and the integration of various methods for classifying nematode species have so far mainly focused on parasitic groups (Blaxter et al. 1998, Nadler et al. 2006) and on a few terrestrial species (Blouin 2002, Abebe & Blaxter 2003). However, a majority of species are free-living and marine (Lambshhead

1993). The taxonomy of marine nematodes almost entirely relies on morphological characters.

Morphological species recognition within the phylum Nematoda has been criticized (Nielsen 1998, Godfray 2002): despite the large morphological diversity (De Ley 2000), classical taxonomy uses only few characters to separate nematode species. In parasitic groups (Coomans 1979) and in a few studies on terrestrial species (e.g. Hodgkin et al. 2000, Ehlers 2001, Susurluk et al. 2001, Abebe & Blaxter 2003), breeding experiments and behavioural observations have been introduced in species delineation. However, successful attempts to culture marine nematodes have been limited to but a few taxa (Moens & Vincx 1998). Molecular techniques, on the other hand, deal with many characters and are practical in virtually all taxa (Blaxter et al. 1998, De Ley et al. 2005). Combining genome wide information has proven to be powerful for the separation of nematode sibling species (De Ley 2000, Derycke et al. 2005), potentially even allowing for the development of a DNA barcoding approach in nematology (Floyd et al. 2002, Blaxter et al. 2005, Bhadury et al. 2006). Nevertheless, the molecular method is also not free of pitfalls and inconsistencies were already observed between conspecific taxa (De Ley et al. 2005). Congruence between independent morphological, molecular, reproductive isolation and behavioural data is probably the best guide to infer whether species boundaries are accurate (de Queiroz 1998).

In this study we address species boundaries based on a combination of phylogenetic and evolutionary principles using molecular data (Adams 1998) and compare these results with morphological data in two free-living nematode species (complexes). Both species (complexes) considered here, *R. (P.) marina* (Bastian 1865) and *Halomonhystera disjuncta* (Bastian 1865), are widespread throughout estuaries and coastal environments worldwide. We used phylogenetic concordance criteria between a mitochondrial and a nuclear locus as a first step to delineate species, and investigated the presence of diagnostic characters for morphological identification with multivariate morphometric analysis. We also included typological taxonomy and - for *R. (P.) marina* - breeding experiments. We argue that such an integrative approach is the best way to overcome potential caveats of any species delimitation method and forms a necessary basis for future studies aiming at pinpointing diversity based on molecular data in the phylum Nematoda.

## MATERIAL AND METHODS

### TAXONOMICAL BASIS

The nominative species *Halomonhystera disjuncta* and *Rhabditis (Pellioiditis) marina* have particularly confused histories. *H. disjuncta* is very recently introduced by Andr ssy (2006) and is formerly known as *Geomonhystera disjuncta*. It has been synonymised with seven other species and has 87 inquirenda descriptions (Jacobs 1987). The situation of *R. (P.) marina* is less chaotic after a review by Inglis & Coles (1961). Prior to their review, *R. (P.) marina* was thought to consist of seven varieties (*danica*, *marina*, *kielensis*, *nidrosiensis*, *septentrionalis*, *norwegica* and *bengalensis*), but the morphological characters and the amount of individuals used to describe them were insufficient to attribute them the species rank. Only *R. (P.) bengalensis* (Timm 1956) was considered a separate species. Another subspecies, *R. (P.) marina mediterranea*, first described by Sudhaus (1974), has been raised to species level based on its pointed tail tip and smaller body size compared to *R. (P.) marina* (Andr ssy, 1983). At present, *R. (P.) marina* is still considered a species complex (Sudhaus & Nimrich 1989).

All the *H. disjuncta* populations studied here agreed with the original species description of *G. disjuncta* (Bastian, 1865), later adapted by Chitwood & Murphy (1964). The genera *Geomonhystera*, *Gammarinema* and *Halomonhystera* are unique by the presence of a sclerotized spinneret chamber and the position of the vulva further than 75 % of the anterior end. The genus *Halomonhystera* is distinctive from *Geomonhystera* by the minute labial sensory organs, scarce and minute cephalic setae, a short oesophagus and rectum, and a gubernaculum with caudal process. *Halomonhystera* comprises all marine species, whereas *Geomonhystera* contains terrestrial species (Andr ssy 2006). *Halomonhystera* is distinct from *Gammarinema* in having a simple, bipartite buccal cavity, less distinct denticles in the stoma, and a farther back located vulva (Andr ssy 2006). *H. disjuncta* is defined by a combination of characters: posterior position of the vulva (> 86 %), six cephalic setae, amphids closer to the head than two labial widths and a simple gubernaculum (Chitwood & Murphy 1964).

The subgenus *Pellioiditis* can be distinguished within the genus *Rhabditis* by the presence of the peloderan (tail-encompassing) bursa and by the presence of nine



precloacal papillae (Sudhaus & Fitch 2001). Species belonging to this subgenus also possess a large pharyngeal sleeve, three or five warts on each metarhabdion, a medial vulva, and three precloacal papillae on the open bursa. *R. (P.) marina* is closely related to *R. (P.) typica* and *R. (P.) littorea* as revealed by the arrangement of the papillae (1+2/3+3) before and after the cloaca (Sudhaus & Fitch 2001). *R. (P.) marina* is distinguishable by its conspicuous cheilorhabdions, poorly developed terminal pharyngeal bulb (as wide as the median bulb), 5-8 lateral longitudinal ridges and bursal papillae arranged in two definite postcloacal groups (Sudhaus & Nimrich 1989). All the *R. (P.) marina* populations considered in this study consent with the first description made by Bastian (1865) and recently adapted by Sudhaus & Fitch (2001).

#### SAMPLING AND SAMPLE PROCESSING

*Halomonhystera disjuncta* and *Rhabditis (Pellioiditis) marina* were sampled in eight and nine locations, respectively, along the coast of Belgium and the southwestern part of The Netherlands. The sampling strategy and sample processing have been described in detail by Derycke et al. (2005). For *H. disjuncta*, 100 specimens from each location were handpicked; 50 of these were randomly sorted and preserved on acetone for molecular analyses, the remaining 50 were mounted into glycerine slides. As a result, molecular and morphological data were obtained from different specimens. The link between molecular lineages and morphology was obtained by measuring specimens from localities where only one (or nearly so) lineage was encountered (see also Chapter 4). For *R. (P.) marina*, 50 specimens from each location were photographed digitally and then preserved on acetone for molecular analyses. In this way, morphological and molecular data were obtained from the same specimens. Morphological measurements were performed on the photographs and on newly collected material from two locations: the Paulina salt marsh and Lake Grevelingen (The Netherlands). This study further included 11 and four *R. (P.) marina* specimens from Boston, USA, and Scotland, UK respectively. For these specimens in glycerine slides, morphological data were linked to molecular lineages by analysing specimens from locations with a single lineage.

## INTEGRATIVE TAXONOMY DATA ANALYSIS

Four taxonomical methods were used. First, sequences of the mitochondrial cytochrome oxidase c subunit 1 gene (COI) and of the nuclear internal transcribed spacer region (ITS) were analysed. All individuals of each nominative species were expected to form a single exclusive lineage. If several exclusive genetic lineages were concordant between the two loci, the genetic lineages were used as coding factors for the multivariate morphometric analysis (MMA). If the MMA did not find significant morphological differences between the molecular lineages, we considered all the lineages as cryptic species. If the MMA indicated the presence of morphological differences between lineages, typological taxonomy was done as a next step to establish if molecular and morphological lineages could be separated by fixed or non-overlapping characters. Finally, hybridisation experiments were conducted to test whether closely related lineages showed indications of reproductive isolation.

a) Molecular phylogenetic analysis

The molecular sequences used in this study were obtained after screening 759 *H. disjuncta* and 1604 *R. (P.) marina* specimens from various populations in Belgium and The Netherlands. Mitochondrial COI and ITS sequences were obtained from three previous studies dealing with the population genetic structure of *R. (P.) marina* and *H. disjuncta* (Derycke et al. 2005, 2006, 2007a), and both genes were amplified from the same DNA samples. We refer to these studies for a detailed description of the amplification and sequencing protocol of both gene fragments. The COI dataset consisted of 50 haplotypes for *R. (P.) marina* and 43 for *H. disjuncta*. All sequences have been submitted to GenBank (*R. (P.) marina*: AJ867447- AJ867478, AM076817-AM076824, AM076817-AM076824; *H. disjuncta*: AM180357-AM180399). The ITS dataset was created as a subset consisting of 3-10 haplotypes of each mitochondrial lineage for each species complex. This resulted in 24 ITS sequences for *R. (P.) marina* and 16 for *H. disjuncta*. Eight of the 24 ITS sequences from *R. (P.) marina* are new (AM398811-AM398818). The other ITS sequences have been submitted to GenBank (*R. (P.) marina*: AJ867057-AJ867072; *H. disjuncta*: AM180400-AM180415).

COI and ITS sequences were aligned in ClustalX v 1.81 (Thompson et al. 1997) using default alignment parameters (gap opening/gap extension costs of

15/6.66). The COI alignment was unambiguous in both nominative species. In contrast, the ITS alignment contained many indels and we identified the ambiguous sites in SOAP 1.2.a 4 (Löytynoja & Milinkovitch 2001). Gap penalties were allowed to range between 11 and 19 with a two-step increase, and extension penalties ranged between 3 and 11, also with a two-step increase. This resulted in the exclusion of 37 sites at the 90 % confidence level in the ITS alignment of *Pellioiditis*. For *H. disjuncta*, we created and used the alignment as in Derycke et al. (2007a). The effect of gaps was investigated by performing phylogenetic analyses with gaps treated as missing data, and subsequently, with gaps treated as a fifth base. The best substitution model for the COI and ITS datasets was determined with Modeltest 3.7 (Posada & Crandall 1998) using the Akaike Information Criterion (Posada & Buckley 2004, Table 5.1). Most parsimonious (MP) and maximum likelihood (ML) trees were calculated in PAUP\* 4.0b10 (Swofford 1999) using a random stepwise addition of sequences and a tree-bisection-reconnection branch swapping algorithm (10 000 rearrangements). Sequences were added in 100 replicate trials. The reliability of the obtained trees was assessed by calculating bootstrap values inferred from 1000 replicates for MP, and from 100 replicates for ML. We additionally performed a Bayesian analysis (BA) using MrBayes v3.1.2 (Huelsenbeck & Ronquist 2005). Four independent Markov chains were run for 500 000 generations (1 000 000 for the COI data of *R. (P.) marina*); a tree was saved every 10<sup>th</sup> generation and the first 10 000 trees were discarded as burn-in. Mr Modeltest was used to determine the evolutionary parameters for the Bayesian analysis. Phylogenetic relationships among haplotype groups are visualised in a NJ tree, calculated in MEGA v3.1 (Kumar et al. 2004). Branch lengths are based on pairwise P- distances.

#### b) Multivariate morphometric analysis (MMA)

The morphological variability in *H. disjuncta* was assessed in 10-15 specimens (males and females) for each lineage from a single location containing individuals belonging to one (or nearly so) molecular lineage (see Chapter 4, Fig 4.1). The total number of males was low (n = 16; females n = 40). For *R. (P.) marina*, morphological variability was assessed in 18-23 specimens for each lineage which were collected from several locations (males, n = 32; females, n = 42), except for lineage PmIV, which was only encountered in Lake Grevelingen. Molecular and morphological data were thus obtained from different specimens, and the link between morphology and

genetic lineages was maintained by measuring specimens from localities containing a single lineage. All specimens were measured (in  $\mu\text{m}$ ) by video capture with the Leica Q500+MC software; curved structures were measured along the arch. In total, 27 and 31 morphological characters were measured for *H. disjuncta* and *R. (P.) marina*, respectively. All the measurements were taken from the anterior to the posterior end. The abbreviations used in the text are listed in Appendix 5.1.

The hypothesis that different lineages within each nominative species did not differ morphologically was tested by a forward stepwise Discriminant Function Analysis (DFA) with the software Statistica 7.1 (Statsoft 2006). If significant differences were observed ( $p < 0.05$ ), a posteriori canonical analysis was performed. This analysis automatically determines an optimal combination of variables so that the first function (root 1) provides the largest overall discrimination between groups. Results were plotted in a scatterplot (root 1 x root 2). Finally, in order to detect significant differences between lineages, p-values and squared Mahalanobis distances ( $D^2$ ) for each pairwise comparison were calculated. Lineages were considered different when  $p < 0.01$ . Characters that were significantly correlated with each other ( $p < 0.05$ ;  $r > 0.8$ ) or characters where the means were significantly correlated with the variance ( $p < 0.05$ ; Cochran test of homogeneity; Sokal & Rolf 1997), even after log transformation, were not considered for the DFA. Males and females were analysed separately.

### c) Typology

In order to test whether molecular and morphological lineages were separated by fixed or non-overlapping characters, all specimens were observed. Selected characters were coded and presented in a polytomous key (Fonseca et al. 2006). One male and one female from each molecular lineage were chosen for representative drawings (See Appendices 5.2, 5.3 and 5.4). Drawings were made with a Leica DMLS microscope.

### d) Breeding experiment

*R. (P.) marina* was sampled at two locations in The Netherlands (Paulina saltmarsh in the Westerschelde estuary and Lake Grevelingen) in February 2006. *Fucus* and *Ulva* fragments were incubated on marine agar for several days. Adult

worms were transferred to fresh agar plates and were stored at 18 °C for about one month in order to acclimatise. Monospecific cultures of cryptic lineages were established by transferring one gravid female and 1-3 males to a fresh plate. In this way, each plate contained the offspring of one female, and hence all nematodes in that plate shared the same mitochondrial DNA as the mother. Subsequently, one nematode was handpicked for DNA-extraction and PCR-RFLP of the nuclear ITS region, which is concordant with the mitochondrial DNA patterns (Derycke et al. 2006, and this study). A 5 µl aliquot of each PCR-product was digested with 0.5 µl AluI restriction enzyme (10 units/µl RE), 1 µl 10x Y+ tango buffer and 3.5 µl distilled water for two hours at 37 °C. The digested PCR-products were subsequently submitted to electrophoresis and bands were stained with ethidiumbromide. Crosses were performed on agar inoculated with 50 µl of a bacterial suspension with a density of  $2 \times 10^{10}$  *E. coli* cells per ml as food. Intra- and interspecific crosses were performed with juvenile females (J3) and adult males from two lineages (PmI and PmIV). All crosses were replicated 20 times. All plates were checked a first time after 24 (intra-lineage crosses) or 48 h (interlineage crosses). If dead males were encountered, they were replaced by new ones. Subsequently, all plates were checked every 48 h during 7 days. We repeated the whole experiment a second time, using J1 instead of J3 juveniles based on evidence that traumatic insemination can sometimes occur in J3 juveniles (T.M. pers. observ.). We replicated the intra- and interlineage crosses five and six times, respectively.

## RESULTS

## MOLECULAR PHYLOGENETIC ANALYSIS

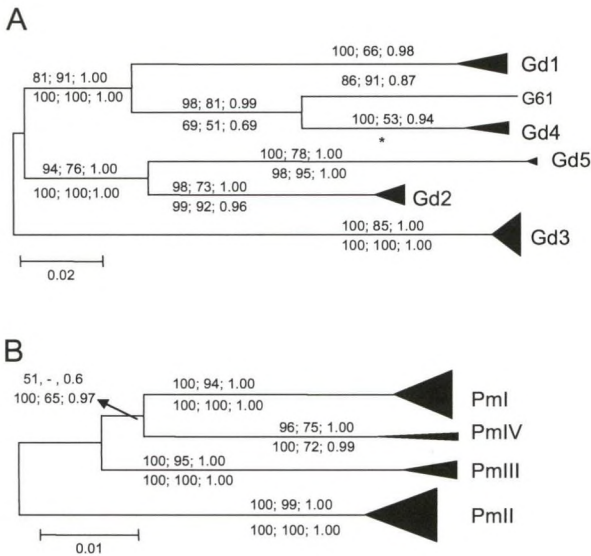

**Fig. 5.1** Phylogenetic relationships among the haplotype groups of *H. disjuncta* (a) and *R. (P.) marina* (b). NJ tree of 43 and 50 COI haplotypes, resp., with branch lengths calculated on the basis of P-distances. Bootstrap values are MP; ML; BA: values above branches are based on COI, values below branches are on ITS (\* Haplotype G61 was pooled within Gd4 for the ITS data).

All four methods of phylogenetic inference yielded highly concordant tree topologies for the mitochondrial and nuclear datasets in *R. (P.) marina* and *H. disjuncta* (Fig. 5.1). For each method (NJ, MP, ML and BA) and for each dataset (COI or ITS), sequences of *H. disjuncta* were divided into five (Fig. 5.1A), and sequences of *R. (P.) marina* into four distinct lineages (Fig. 5.1B).

Divergence levels of COI within each lineage were low (0.32 - 2.56 % in *H.*

*disjuncta* and 0.25-2.3 % in *R. (P.) marina*), while high divergences were observed between lineages. The COI divergences were at least two times higher in *H. disjuncta* than in *R. (P.) marina* (Table 5.1). The nuclear ITS variation was also higher in *H. disjuncta* than in *R. (P.) marina* (Table 5.1) and showed well supported interspecific relationships for *H. disjuncta*: Gd1 - Gd4 and Gd2 - Gd5 were more closely related to each other than to any other lineage (Fig. 5.1A). These interspecific relations were better resolved in the nuclear than in the mitochondrial dataset. In contrast, interspecific relationships within *R. (P.) marina* were poorly resolved. In both nominative species, the monophyly of all lineages was well supported in the mitochondrial and nuclear datasets (Fig. 5.1). Each lineage was also characterized by

a substantial number of fixed differences (6-19 in *H. disjuncta* and 3-7 in *R. (P.) marina*).

	COI		ITS	
	<i>H. disjuncta</i>	<i>R. (P.) marina</i>	<i>H. disjuncta</i>	<i>R. (P.) marina</i>
Alignment length	311	396	892	847
# variable sites	117	83	258	239
# parsimony informative	112	64	245	229
% divergence	13.8 - 25.7	5.8 - 10.6	1.0 - 24.7	3.3 - 21.1
evolutionary model	HKY + I + G	K81uf + G	TRN + G	GTR + I

**Table 5.1** Phylogenetic parameters, percentage divergence and the substitution model chosen by Modeltest using AIC for COI and ITS in *H. disjuncta* and *R. (P.) marina*.

#### MULTIVARIATE MORPHOMETRICS

Of the 27 characters measured in *H. disjuncta*, only five were selected by the Discriminant Function Analysis (DFA). For females, these characters were tail length, head diameter, buccal cavity length, ratio a and vulva-anus/tail. The latter character was replaced by spicule length in males. Females from Gd3 were the most divergent, while females from Gd1 and Gd4 were morphologically similar ( $p > 0.01$ ; Table 5.2 upper right). All other pairwise comparisons showed significant morphological differences (Table 5.2). For males, significant differences between lineages were fewer (Table 5.2 lower left). It is important to note, however, that the number of individuals used for the statistical analysis of males is lower than for females (see material and methods, and Fig 5.2a and b). For males, the results from the canonical analysis (Fig. 5.2a) separated all lineages, while for the females Gd1 and Gd4 still formed one single cluster (Fig. 5.2b). Of the 31 measured characters in *R. (P.) marina*, 10 were selected by the DFA for males (L, a, b, c, spic/abd, Post-int/abd, testis/L, nr%, Bcl/BcW, BcL/head) and 9 for females (as for males, except spic/abd was replaced by V%, and testis/L was deleted). There were significant differences between all lineages independent of gender. For males and females, the first two roots of the canonical analysis yielded similar results, separating the lineages in four groups with PmI and PmIV closer together (Fig. 5.2c, d).

	Gd1	Gd2	Gd3	Gd4	Gd5	PmI	PmII	PmIII	PmIV
Gd1		11.4*	17.8*	3.92	14.5*		8.6*	33.8*	17.3*
Gd2	9.1		13.2*	12.7*	23.4*	PmII	37.2*	25.6*	28.7*
Gd3	22.8	33.1*		24.8*	31.4*	PmIII	71.3*	45.2*	69.8*
Gd4	6.3	7.9	41.4*		9.4*	PmIV	24.1*	61.1*	117.4*
Gd5	46.3*	54.7*	8.5	68.0*					

**Table 5.2.** Squared Mahalanobis distances ( $D^2$ ) between lineages of the *Halomonhystera disjuncta* (Gd) and *Rhabditis (Pellioiditis) marina* (Pm) nominative species. Upper right is the distance between females and lower left the distances between males. \*:  $p < 0.01$ .

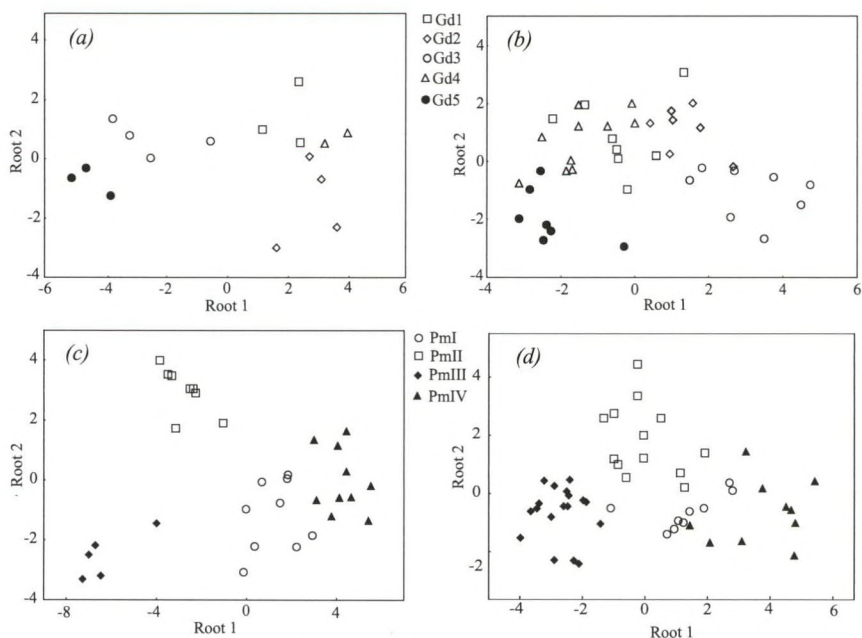

**Fig. 5.2** Scatterplot of the canonical measures calculated after the Discriminant function analysis (DFA) for the multivariate morphometrics along the first two roots. a- males and b- females of the *H. disjuncta* lineages; c- males and d-females of the *R. (P.) marina* lineages.

### TYPOLGY

In total, seven fixed and non-overlapping characters were selected to distinguish all five *H. disjuncta* lineages, and males and females were needed to separate them. Gd3 was the most divergent lineage because of the absence of an apophysis and post- and pre-anal supplements (Table 5.3). Lineage Gd1 shared more characters with Gd4, and lineage Gd2 with Gd5.

	Apop Abs = 0 Pres = 1	Pos-supplem Abs = 0 Faint = 1 Prominent = 2	Pre-supplem Abs = 0 Pres = 1	Spic/abd 1 < 1.7 2 > 1.7	Head ♂ (μm) 1 < 10 2 > 10	Tail ♀ (μm) 1 < 90 2 > 90	Ratio a 1 < 30 2 > 30
Gd1	0	0,1	1	1	2	2	1,2
Gd2	1	2	1	1	1	1	2
Gd3	0	0	0	1	1	1	1
Gd4	0	1	1	1	2	1	1,2
Gd5	1	2	0	2	1	1	1

**Table 5.3.** Polytomouskey for the identification of *Halomonhystera disjuncta* lineages. Apop: apophysis; supplem: supplement; spic: spicules; abd: anal body diameter; a: body length divided by body width. Abs: absent, Pres: present.



Based on five non-overlapping and one fixed character, it was possible to differentiate all lineages of *R. (P.) marina*, when both genders were observed (Table 5.4). The distribution of characters shows that PmIV was the most divergent lineage and that PmII shared more characters with PmIII than with the other lineages.

	L ♂ (µm)	L ♀ (µm)	Testis/L	Phx ♀ (µm)	Ratio c'♀	Phx-Intest Junction	Ratio c ♀
	1 < 1460	1 < 2400	1 < 0.78	1 < 297	1 < 3	straight = 1	1 < 16.5
	2 = 1460-1700	2 < 2400	2 > 0,78	2 > 297	2 > 3	folded = 2	2 > 16.5
	3 > 1700		3 > 0.93			invaginated = 3	
PmI	2,3	1,2	1	2	1,2	1	2
PmII	1,2	1	2	1,2	1	2	2
PmIII	1	1	2	1	2	2	1
PmIV	3	2	3	2	1,2	3	2

**Table 5.4.** Polytomous-key for the identification of *Rhabditis (Pellioiditis) marina* lineages. L: total body length; Phx: length of the pharynx; c': tail length divided by anal body diameter; c: body length divided by tail length, Phx-Intest Junction: pharynx-intestin junction.

BREEDING EXPERIMENTS

PCR-RFLP analyses indicated that all nematodes we isolated from Lake Grevelingen belonged to lineage PmIV, and all nematodes from Paulina were PmI. Interestingly, the monospecific stock cultures of PmIV produced offspring much more quickly than those of PmI, and we also observed differences in behaviour and motility between both lineages.

1st experiment		PmI ♀	PmIV♀	Hybridisation	was
	PmI ♂	3 (19)	1 (18)	considered successful when juveniles were observed on the agar plates after 7 days of incubation. Success rate of all the intralineage crosses varied from 16 % to 66 % (Table 5.5).	
	PmIV ♂	0 (20)	4 (18)		
<u>2nd experiment</u>					
	PmI ♂	4 (6)	0 (5)		
	PmIV ♂	0 (5)	2 (5)		

**Table 5.5.** Number of plates with successful reproduction between lineages PmI and PmIV from two experiments. Values between brackets stand for number of replicates.

Out of 38 interlineage crosses in the first experiment (with J3), only one produced juveniles. Out of 10 interlineage crosses in the second experiment (with J1), not a single one produced offspring.

## DISCUSSION

The integrative approach used in this study confirmed the presence of multiple species within each nominative species. First, the concordant patterns in two independently evolving markers (mitochondrial DNA and ITS) indicate that the deeply diverged lineages within *H. disjuncta* and *R. (P.) marina* are phylogenetic and genealogical species. Each lineage also harbours a substantial amount of fixed molecular differences, but the assessment of fixed differences is strongly dependent on sample size (Wiens & Servedio 2000). The levels of divergence between the lineages of either nominative species are well within the range of those observed between congeneric nematode species (Radice et al. 1988, Powers et al. 1997, Blouin 2002), but the level of sequence divergence is too variable across taxa to be a good universal predictor for species delimitation (Ferguson 2002, Cognato 2006). We therefore delineated species on the basis of phylogenetic and evolutionary principles as proposed by Adams (1998, 2001).

ITS sequences are common for species identification in nematology (Powers et al. 1997, Nguyen et al. 2001, Spiridonov et al. 2004). Moreover, the combination of conserved (5.8S) and variable (spacers) portions renders the ITS region useful for phylogenetic as well as population genetic studies (De Ley et al. 2005). However, as indicated by the low divergence between the closely resembling lineages Gd1 and Gd4, ITS divergence between congeneric species may sometimes be too low for reliable species delineation (Ferris et al. 1993, Kaplan 1994). Alternatively, mitochondrial DNA provides an orthologous set of genes with little or no recombination and rapid evolution (Ballard & Rand 2005). Applications of mitochondrial DNA markers to species identification in nematodes have been few, even though mitochondrial DNA quickly reaches reciprocal monophyly between closely related species, with divergences usually higher than 10 % (Blouin et al. 1997, Hoberg et al. 1999, Derycke et al. 2005, and present study). On the other hand, mitochondrial genomes are very diverse within the phylum hampering the use of a phylum-wide primer. Moreover, due to its matrilineal mode of inheritance, phylogenetic patterns (relationship among lineages) can be confounded by tokogenetic patterns (relationship within lineage) (Ballard & Rand 2005). Heteroplasmy, i.e. different copies of mitochondrial DNA in the same individual, may also confound species delimitation from phylogenetic relationships. Heteroplasmy has

recently been detected in a number of *Meloidogyne* species where intraindividual divergence was 0.3 % (Tigano et al. 2005). The SSCP-method is capable of distinguishing DNA-sequences containing one base substitution, and for heteroplasmic individuals, multiple banding patterns are expected (Steel et al. 2000). We did not observe any ambiguities in our SSCP-profiles and therefore render effects of heteroplasmy to be unimportant in this study. Furthermore, the combination of ITS and mitochondrial DNA provides a powerful means of inferring relationships between lineages and establishing their species identity.

All the molecular lineages of the *R. (P.) marina* and most lineages of the *H. disjuncta* species complex were in agreement with the MMA. For the latter, lineages Gd1 and Gd4 were morphologically similar, which may be related to the restricted number of morphological characters selected for each analysis and to the low number of individuals sampled. The set of morphological characters for identifying sibling species may be largely dependent on the number of populations and individuals analysed: when a higher number of populations are studied, more variability is introduced, and significant differences will only be detected if the populations are well sampled (Wiens & Severido 2000). Consequently, while for the molecular data, the variation within lineages was lower than between lineages, for the morphological data this pattern was not consistent (Fig. 5.3). These differences between methodologies can be explained by the particular pattern of morphological variation

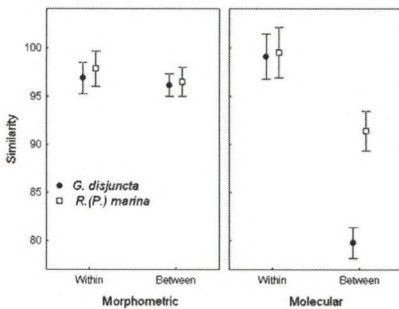

**Fig. 5.3** Means and 95 % confidence intervals for the similarities of the multivariate morphometric (Euclidean distance) and molecular data (Tamura & Nei distances) comparing the variability within and between lineages from both species complexes.

in which between-species differentiation is small relative to within-species variation (Wiens & Penkrot 2002). In addition, the number of diagnostic morphological characters within both nominative species was relatively small, and some of these characters showed extensive variation within populations and lineages. An alternative explanation for the differences between morphology and the molecular data is more theoretical: most of the variation in mitochondrial genes within a species is selectively neutral, suggesting

that haplotype frequencies are governed primarily by migration and genetic drift (Ballard & Rand 2005), which are independent of morphological changes. Morphological variability is the outcome of processes that operate at different scales and levels of organisational complexity (Monteiro et al. 2000). Therefore, as observed by other authors (Wiens & Penkrot 2002, Puerto et al. 2001), molecular variability within and between lineages is not necessarily a good proxy of morphological variability.

Typological taxonomy in the *H. disjuncta* complex supported the results of the molecular analysis and separated all the groups identified by MMA, confirming the presence of five sibling species. For *R. (P.) marina*, typology also separated the four lineages found with both other methods. However, in both species complexes, typological taxonomy often separated closely related species by only one or two non-overlapping characters. The low morphological divergence between closely related species hampers proper species diagnosis (Wiens & Severido 2000). Moreover, the relationships between lineages based on typology were not always consistent with the results generated with MMA. While typology identified PmIV as the most divergent lineage in the *R. (P.) marina* complex, MMA and molecular analysis grouped PmIV with PmI. These matches and mismatches between data sets highlight the problem of selecting few characters for morphology-based species identification and phylogeny. This is mainly because morphological characters are not necessarily phylogenetically informative and may be influenced by ecological factors or sexual dimorphism. For example, although body length and width are commonly used to separate species in some free-living nematode genera, they are also strongly dependent on gender, food availability and temperature (Schiemer 1982, Herman & Vranken 1988).

Additional diagnostic power for species delineation may come from observations on reproduction and behaviour (Dayrat 2005). Results of the breeding experiment between the closest related lineages PmI and PmIV suggest that they are different biological species. Reproduction was only observed in the intralinesage crosses, with the exception of a single successful interlinesage cross, which was probably caused by (traumatic) insemination just prior to the experiment. In addition, we observed different behavioural patterns and reproduction rates in the stock cultures of PmI and PmIV, PmI typically being less motile and reproducing more slowly.

As shown in this study, even "slight" morphological differentiation corresponds to different molecular lineages and may also result in reproductive

isolation. Similar observations have been reported in rotifers (Suatoni et al. 2006), bryozoans (Gomez et al. 2007), foraminifera (Holzmann 2000) and diatoms (Beszteri et al. 2005, Amato et al. 2006, Lundholm & Moestrup 2006). For the two species complexes studied here, we may assume that a considerable part of the morphological variability reported in the literature corresponds to a similar variety of sibling species. For instance, we observed body length variation within *H. disjuncta* between 0.77 mm and 1.2 mm, compared to a range from 0.5 mm to more than 1.6 mm in the 87 taxonomical descriptions (sensu Jacobs, 1987) from different continents. The length of the male copulatory organs (spicules) varied between 29 and 44  $\mu\text{m}$  in the present study and from 25 to 42  $\mu\text{m}$  in the literature. In addition, variability in the presence/absence of pre- and post-cloacal supplements and differences in the shape of the apophysis are commonly observed. Similar examples are also common in *R. (P.) marina*. It was previously assumed that *R. (P.) marina* consisted of two morphological groups occurring in separate regions: females with a pointed tail tip occurring in the southern hemisphere, and females with a rounded tip occurring in the northern hemisphere (Sudhaus, 1974). Sudhaus (1974) also mentioned that body length in *R. (P.) marina* varies from 0.8 mm to more than 3 mm, and buccal cavity length from 16 to 40  $\mu\text{m}$ , with smaller individuals in the south and bigger specimens in the north. In our study, body length ranged from 1.3 to 3.6 mm, while the length of the buccal cavity varied between 14.5  $\mu\text{m}$  and 28  $\mu\text{m}$ . Hence, the many free-living nematode species for which a high morphological variability has been described are likely to represent a substantial hitherto unrecognized species diversity, rendering most diversity estimates for the phylum Nematoda hugely inadequate.

For taxa where a majority of the species remains to be described, and where morphological and molecular variability are poorly known, the selection of few morphological characters, or of a single molecular marker, for delineating species boundaries is inadequate (e.g. Holzmann 2000, Gomez et al. 2007). By contrast, our a priori use of molecular data - based on more than one marker - to code the morphological dataset for multivariate analysis and, ultimately, for pinpointing morphological identification characters proved to be very effective. Although such integrative taxonomy requires substantial expertise and time, and is therefore not applicable for routine identification work, it is at this point the best way to accurately delimit species in taxa with unknown biodiversity (Dayrat 2005, Will et al. 2005). Hence, it is important that model studies on integrative taxonomy highlight the

limitations of various identification methods in different taxa, allowing to choose the best strategy for future identifications.

## **ACKNOWLEDGEMENTS**

The authors acknowledge H. Steel and B. Verstraeten for their help with the breeding experiments. G.F. is supported by the Brazilian Ministry of Science and Technology (CNPq). S.D. acknowledges a grant from the Flemish Institute for the Promotion of Scientific-Technological Research (I.W.T.). T.M. is a postdoctoral fellow with the Flemish Fund for Scientific Research. Further financial support was obtained from Ghent University in BOF-projects 0110600002 and 01GZ0705 (GOA-BBSea).

**Appendix 5.1.** Measurements of morphological characters. A-B, D-E: *Halomonhystera*, A: head region, B: total body, D: tail region female, E: tail region male; B: *Pellioiditis*, pharyngeal region.

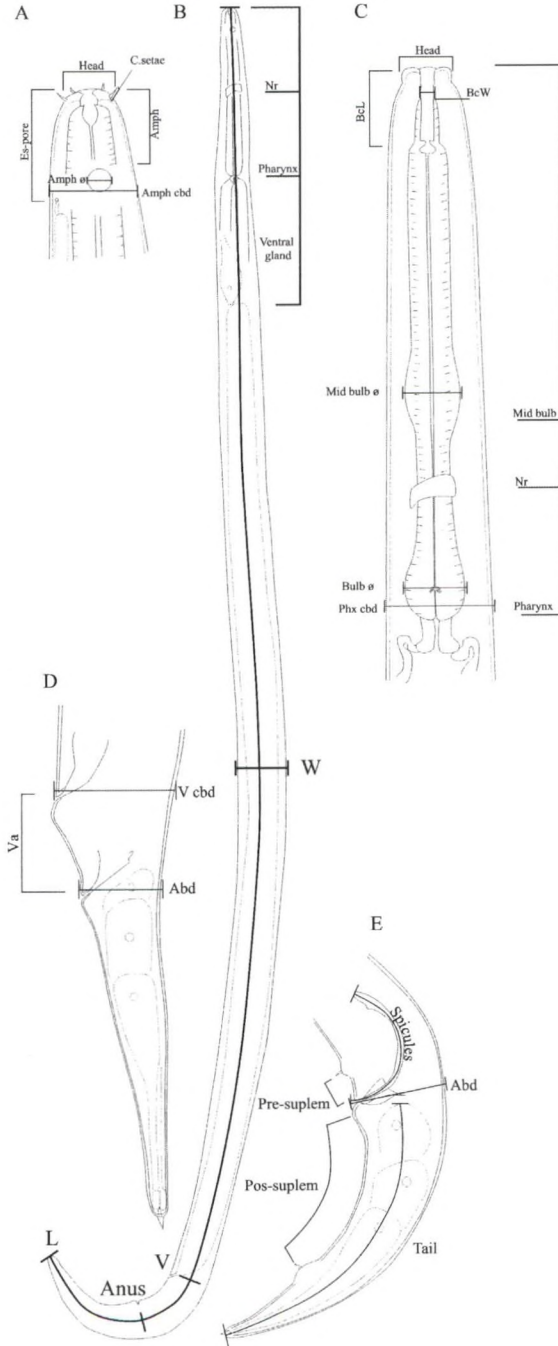

Appendix 5.2. Drawings of the *Halomonhystera disjuncta* species complex. a-e: Gd1; f-j: Gd4; k-o: Gd2; p-t: Gd5

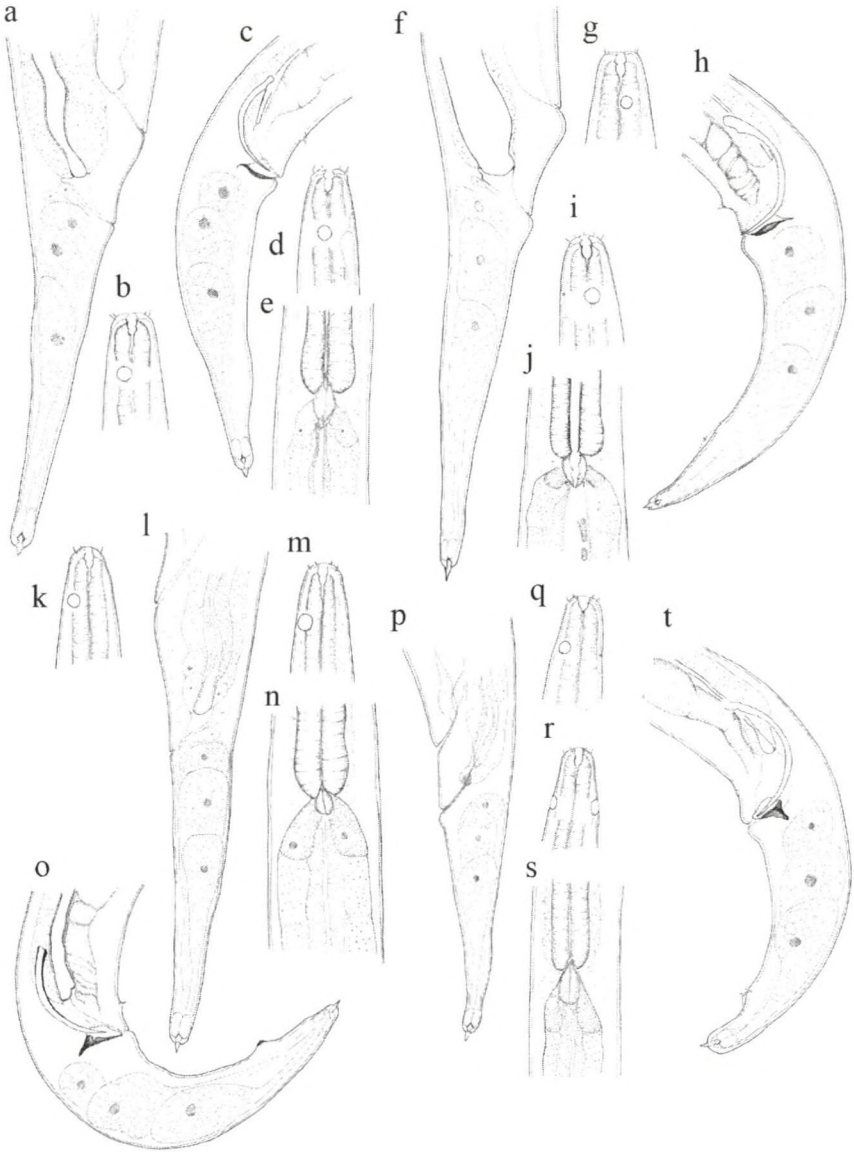



Appendix 5.3. Drawings of *Halomonhystera disjuncta*, species Gd3. a-c: male; d-e: female.

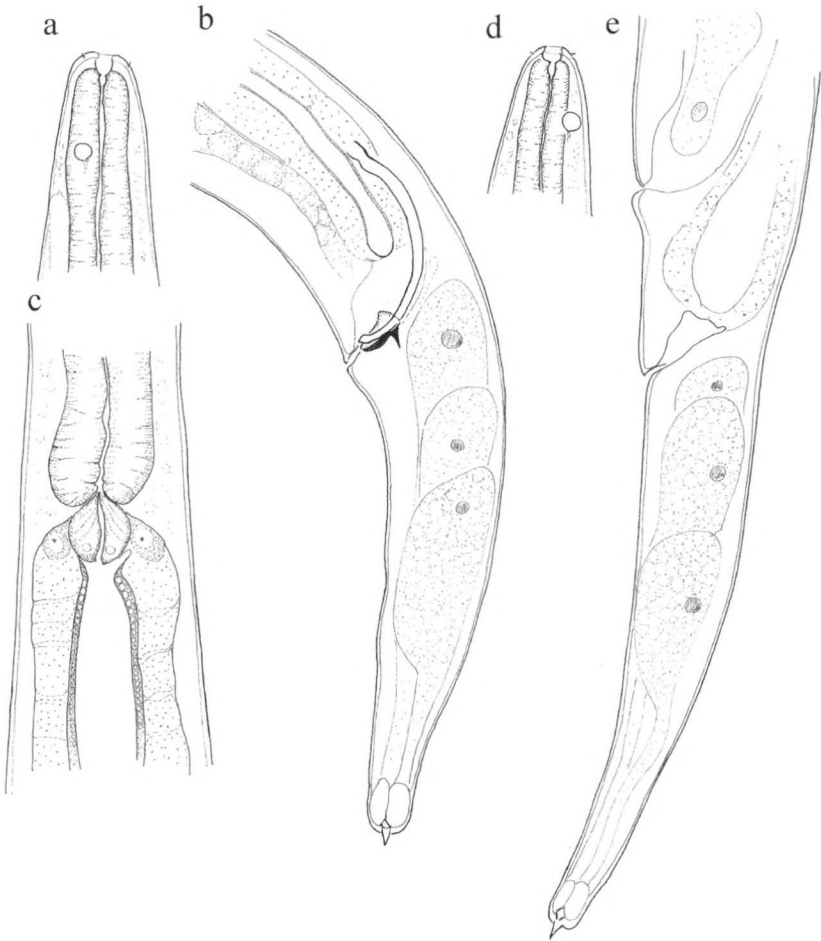

**Appendix 5.4.** Drawings of the *Rhabditis (Pellioditis) marina* species complex. a-c: PmI; d-e: PmIV; f-h: PmIII; i-j: PmII

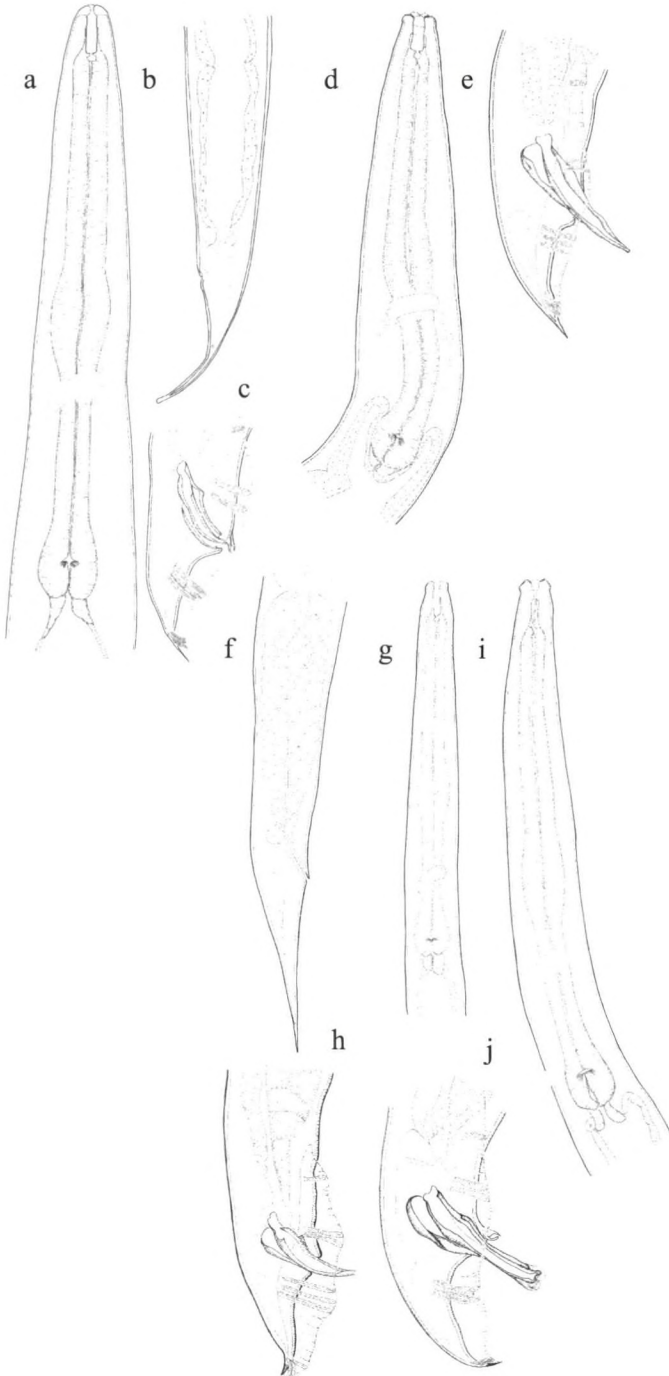

118966

---

CHAPTER VI  
DISENTANGLING TAXONOMY WITHIN THE *RHABDITIS*  
(*PELLIODITIS*) *MARINA* (NEMATODA, RHABDITIDAE)  
SPECIES COMPLEX USING MOLECULAR AND  
MORPHOLOGICAL TOOLS

---

Accepted with minor revision for publication in Zoological Journal of the Linnean Society as:

Derycke S, Fonseca G, Vierstraete A, Vanfleteren J, Vincx M, Moens T. Disentangling taxonomy within the *Rhabditis (Pellioditis) marina* (Nematoda: Rhabditida) species complex using molecular and morphological tools.

**ABSTRACT**

Correct taxonomy is a prerequisite for biological research, but currently it is undergoing a serious crisis, resulting in the neglect of many highly diverse groups of organisms. In nematodes, species delimitation remains problematic due to their high morphological variability. Evolutionary approaches using DNA sequences can potentially overcome the problems caused by morphology, but they are also affected by flaws. A holistic approach with a combination of morphological and molecular methods can therefore produce a straightforward delimitation of species.

The present study investigates the taxonomic status of some highly divergent mitochondrial haplotypes in the *Rhabditis (Pellioiditis) marina* species complex by using a combination of molecular and morphological tools. We used concordance among phylogenetic trees of three molecular markers (COI, ITS, D2D3) to infer molecular lineages. Subsequently, morphometric data from nearly all lineages were analysed with multivariate techniques. The results showed that highly divergent genotypic clusters were accompanied by morphological differences, and we created a graphical polytomous key for future identifications. This study indisputably demonstrates that *R. (P.) marina* and *R. (P.) mediterranea* belong to a huge species complex and that biodiversity in free-living marine nematodes may seriously be underestimated.

## INTRODUCTION

Nematodes have high species diversity as well as high abundances in marine, freshwater and terrestrial environments. Species delimitation in nematodes remains problematic mainly due to the high morphological variability among populations which reduces the number of diagnostic characters (Coomans 2002, Nadler 2002, Powers 2004). Molecular techniques and phylogenetic analyses may overcome this problem, and barcoding seems a promising tool to assess biodiversity in free-living nematodes (Floyd et al. 2002, Blaxter et al. 2005, Bhadury et al. 2006). However, it is difficult to decide when individuals are sufficiently distinct to discern them as different species based on sequence divergence. This is mainly due to the lack of a straightforward relationship between genetic divergence and reproductive isolation (Ferguson 2002), to the occurrence of theoretical observations (like incomplete lineage sorting, incongruence between gene and species trees Avise 1995, Nadler 2002), and to discrepancies between morphological and molecular data. Many examples of morphological stasis despite substantial genetic differentiation have been observed in nematode genera (e.g. *Caenorhabditis* Butler et al. 1981, *Globodera* and *Heterodera* Bakker & Bouwman-Smits 1988), while morphological differentiation between genetically similar species has also been reported (De Ley et al. 1999).

The problems of either morphological or molecular species delimitation can be resolved by applying a holistic approach, in which analyses of several independently evolving molecular markers circumvent the theoretical observations of the molecular method. Subsequently, the observed phylogenetic lineages can be used to aim more precisely for diagnostic morphological characters between nematode lineages (Coomans 2002, see also Chapter 5).

In a recent study on the phylogeny and systematics of the Rhabditidae, Sudhaus & Fitch (2001) considered *Pellioiditis* Dougherty (1953) as one of the 15 subgenera within the genus *Rhabditis* Dujardin (1845). The subgenus comprises 18 species (Andrassy 1983, Sudhaus & Nimrich 1989, Gagarin 2001), only four of which inhabit the marine environment. *Rhabditis (Pellioiditis) marina* Bastian, 1865 has been reported most frequently (Inglis & Coles 1961, Sudhaus & Nimrich 1989). The large intraspecific variability within *R. (P.) marina* is reflected in the description of a number of varieties, all but one of them later having been considered as synonyms of *R. (P.) marina* (Inglis & Coles 1961). A recent study based on mitochondrial and

nuclear DNA sequences revealed at least four cryptic species within *R. (P.) marina*, all of which were sympatrically distributed on a fairly small geographical scale (100 km) (Derycke et al. 2005) and were morphologically distinguishable (See Chapter 5). In addition, a temporal survey in which more than 1600 individuals were analysed led to the discovery of specimens with highly divergent DNA sequences (referred to as the Z lineages), of which the taxonomic position and phylogenetic relationships with the other lineages remained unclear (Derycke et al. 2006).

The present study aims to elucidate the phylogenetic and taxonomic uncertainties in the *R. (P.) marina* species complex through a combination of molecular and morphological methods. We performed phylogenetic analyses on three genes (mitochondrial COI, nuclear ITS and D2D3 regions) and used concordant tree topologies between these genes as evidence for independent evolutionary histories. We subsequently used multivariate analyses of morphological characters to investigate whether the observed genetic differences were accompanied by morphological differences and created a polytomous key for future identifications.

## MATERIAL AND METHODS

### SAMPLE COLLECTION AND PROCESSING

A detailed description of the sampling strategy and isolation protocol of *R. (P.) marina* has been described in Derycke et al. (2006). From the 1615 individuals analysed in that study, 11 individuals from Blankenberge, a coastal location situated in the northern part of the Belgian coastline (51° 19' N, 3° 8' E), possessed highly divergent mitochondrial COI haplotypes (called Z, Z2 and Z3). Prior to molecular analysis, each of the 1615 specimens were transferred to an embryo dish containing sterile artificial seawater, which was briefly heated to 60 °C to kill the nematodes. Each nematode was transferred in a drop of sterile distilled water on a glass slide and photographed digitally under a Leica DMR microscope equipped with a Leica DC 300 camera. These pictures served as a morphological back-up. Subsequently, each nematode was preserved in an Eppendorf reaction tube of 0.5 ml filled with acetone. Morphological and molecular data were thus obtained from the same specimens.

For the present study, we additionally used specimens collected in the frame of an ongoing larger-scale phylogeographic study of *R. (P.) marina* (see Chapter 9). Nematodes with Z haplotypes were collected in South Africa (Ngazi estuary) and eastern Mexico (Playa del Carmen, Yucatan). Collection sites for all lineages are summarized in Table 6.1. The morphological back-up of these nematodes was created by randomly picking 5 - 10 adult specimens from each location and mounting them into glycerin slides according to Vincx (1996). The remaining specimens were preserved on acetone for molecular analyses. Here, morphological and molecular data were thus obtained from different specimens. The link between both datasets was maintained because each location contained only one molecular lineage.

Morphological back-up	Digital pictures								Glycerin slides								
	Lineage	PmI	PmII	PmIII	PmIV	Z	Z2	Z3	Z4	PmI	PmII	PmIII	PmIV	Z	Z2	Z3	Z4
Location																	
Belgium - Blankenberge		X	X			X	X	X									
Belgium - Nieuwpoort	X																
The Netherlands - Westerschelde	X	X	X							X							
The Netherlands - Oosterschelde	X		X														
The Netherlands - Lake Grevelingen		X			X								X				
UK - Scotland (Westroy)										X							
USA - Massachusetts (Boston)											X						
Mexico - Yucatan																	X
South Africa - Ngazi estuary													X	X			

**Table 6.1:** *Rhabditis (Pellioditis) marina*. Collection of specimens from each lineage. Specimens from pictures were collected in Belgium and The Netherlands (100 km), while specimens in slides were collected worldwide.

### Molecular data

The DNA-extraction protocol, PCR-amplification, screening of genetic variation in the mitochondrial cytochrome oxidase c subunit 1 gene (COI) with the SSCP method and primer sequences are described in Derycke et al. (2005). The COI gene was amplified from 1 µl of genomic DNA, and with primers JB3 and JB5, and all samples with different SSCP band mobility patterns were sequenced with the ABI 3130XL capillary DNA sequencer. The sequencing reaction was performed with the BigDye Terminator v 3.1Mix (PE Applied Biosystems) under the following conditions: an initial denaturation of 2 min at 98 °C was followed by 40 cycles of denaturation at 98 °C for 10 s, annealing at 50 °C for 5 s and extension at 60 °C for 60 s. Both strands were sequenced using the amplification primers. DNA samples were stored at -80 °C so that multiple loci could be amplified from the same specimens.

Subsequently, we created a subset of individuals (n = 28) based on the COI topology and sequenced two nuclear loci. The highly variable ribosomal internal transcribed spacer region (ITS1, 5.8S and ITS2) was amplified as described in Derycke et al. (2005). The D2D3 expansion segments of the conserved 28S ribosomal DNA were amplified using primers D2A (5' ACAAGTACCGTGAGGGAAAGTTG 3') and D3B (5' TCCTCGGAAGGAACCAGCTACTA 3'). Amplification of this fragment started with a denaturation at 94 °C for 5 min, followed by 40 cycles of denaturation at 94 °C for 30 s, annealing at 58 °C for 30 s and extension at 72 °C for 60 s, and was terminated by a final extension period of 10 min at 72 °C. Both nuclear fragments were amplified from 1 µl genomic DNA, and both strands were sequenced with the amplification primers. New COI, ITS and D2D3 sequences are submitted in GenBank (Accession numbers: AM398819 – AM398833; AM399037 – AM399068).



### Morphological data

Morphological variability in males and females containing the Z haplotypes was compared with that of the four lineages PmI, PmII, PmIII and PmIV (Chapter 5) in two ways. First, a detailed investigation was performed on specimens mounted into glycerin slides. These specimens were collected worldwide (Table 6.1) and were measured by video capture with the Leica Q500+MC software. A total of 29 morphological characters were considered, 11 of which were shape parameters (Table 6.2). A detailed description of all morphological characters can be found in Chapter 5, Appendix 5.1.

Morphometric characters	abbreviation	slides	pictures
Body length	L	X	X
Body width	W	X	X
Pharynx length	Ph	X	X
Pharynx corresponding body diameter	Phcbd	X	X
Position of the mid-bulb from the anterior end	Mid-bulb	X	
Nerve ring	nr	X	X
Midbulb diameter	M bulb diam	X	
Bulb diameter	Bulb diam	X	
Position of the anus	anus	X	X
Tail length	tail	X	X
Testis length	testis	X	X
Buccal cavity length	bc L	X	X
Buccal cavity width	bc W	X	X
Head length	head	X	X
Spicule length	spic	X	X
	Pos-intest	X	X
Anal body diameter	abd	X	X
Vulva	v	X	X
<b>Shape parameters</b>			
L/W	a	X	X
L/Ph	b	X	X
L/Tail	c	X	X
	c'	X	X
	spic/abd	X	X
	V%	X	X
	Pos-Int/abd	X	X
	testis/L	X	X
	nr%	X	X
	bcL/w	X	X
	bcl/head	X	X

**Table 6.2:** Morphometric characters and shape variables used for morphological identification of the Z lineages. Characters measured on specimens in slides and pictures are indicated with a cross.

Second, to compare the degree of morphological differentiation due to geographical variation, results from the first dataset were compared with those of

measurements from specimens collected in populations from Belgium and The Netherlands. These measurements were performed on a subset of characters (those that were used in the discriminant analysis, see next section) on the digital pictures (Table 6.2). Morphological and molecular data for this second analysis were from the same set of individuals. Drawings were made with a Leica DMLS microscope (Appendix 6.2).

#### DATA ANALYSES

##### Molecular data

Sequences of each locus (COI, ITS, D2D3) were aligned in ClustalX v.1.81 (Thompson et al. 1997) using default parameter settings (gap opening/gap extension costs of 15/6.66). We also amplified COI, ITS and D2D3 sequences from *R. (R.) nidrosiensis*, which was isolated from decomposing algae in The Netherlands (Derycke et al. 2005), and from *R. (P.) mediterranea* (New Zealand). Deeper phylogenetic relationships between our *R. (P.) marina* sequences and sequences of *R. (R.) nidrosiensis* and *R. (P.) mediterranea* were inferred from the nuclear dataset, which was rooted with sequences from the nematodes *Ancylostoma caninum* (D2D3: AM039739; ITS: DQ438079) and *Necator americanus* (D2D3: AM039740; ITS: AF217891) obtained from GenBank. Both species belong to the same order (Rhabditida) as *R. (P.) marina*.

An unambiguous alignment was obtained from the COI sequences, while indels were observed in both nuclear loci, especially for the ITS region. Hence, each of the two nuclear alignments was checked for unreliable positions in SOAP 1.2.a4 (Löytynoja & Milinkovitch 2001), using the following Clustalw parameter range: gap penalties were allowed to range between 11 and 19 with a two-step increase, and extension penalties ranged between 3 to 11, also with a two-step increase. We used a threshold level of 90 % for the D2D3 locus, which resulted in the removal of 17 unreliable positions. The threshold level for the ITS alignment was created as follows: first, we removed the outgroup sequences *N. americanus* and *A. caninum*. At the 90 % level, 713 out of 913 sites appeared unreliable. However, manual inspection of the alignment showed that many of these 'unreliable sites' did not contain much variation among sequences. Therefore, we lowered the threshold level until all indel events remained excluded. This was at the 60 % level. Second, we also excluded *R. (R.)*

*nidrosiensis* from the dataset, which resulted in the exclusion of ‘only’ 277 out of 903 positions at the 90 % level. Hence, the alignment of ITS sequences within *Pellioiditis* was highly reliable at the 90 % level, and the threshold for the ITS alignment including *N. americanus*, *A. caninum* and *R. nidrosiensis* was set at 60 %.

Prior to phylogenetic analysis, the appropriate model of evolution for each locus was determined with Modeltest 3.7 (Posada & Crandall 1998) using the Akaike Information Criterion (AIC) (Posada & Buckley 2004). For each dataset, the overall transition/transversion ratio was calculated using the values from Modeltest. The COI dataset was screened for saturation at first, second and third codon positions by calculating the uncorrected pairwise distances and corrected maximum likelihood distances for each codon position in Paup. A linear relationship between both distances indicates that no saturation has occurred. Phylogenetic relationships were calculated for each locus separately according to three methods: most parsimonious (MP) and maximum likelihood (ML) trees were calculated in Paup 4.0 beta 10 (Swofford 1998) using heuristic searches and a tree-bisection-reconnection branch swapping algorithm (10 000 rearrangements), and a random stepwise addition of sequences in 100 replicate trials. One tree was held at each step. Robustness of the obtained trees was tested by bootstrapping with 1000 replications for MP and 100 replications for ML and 10 replicate trials of sequence addition. Gaps were treated as missing data. In addition, a Bayesian analysis was performed in Mr Bayes v 3.1.2 (Huelsenbeck & Ronquist 2005). Four independent Markov chains were run for 500 000 generations and a tree was saved every 10<sup>th</sup> generation. The first 10 000 trees were discarded as burn-in. The best model for Bayesian analysis of the three loci was determined with MrModeltest 2.2 (Nylander 2004) using the Akaike Information Criterion (AIC).

We subsequently performed an incongruence length difference (ILD) test (Mickey & Farris 1981) in Paup to investigate whether the different gene fragments could be combined in one analysis.

### Morphological data

Morphological differences among the molecular lineages were analysed using backward stepwise discriminant function analyses (DFA) in Statistica 6.0 (Statsoft 2001). DFA determines which variables are best to discriminate between a priori defined groups. In our study, we defined eight groups based on the molecular COI

data (PmI, PmII, PmIII, PmIV, Z, Z2, Z3 and Z4). We only had information on one specimen for haplotype Z3, and hence it was removed from the dataset. Variables which were correlated with each other above the 0.8 level were omitted. This threshold was determined after calculation of the correlation between variables that are expected to be correlated (e.g. length and width, length and tail length, tail and anal body diameter). Morphological characters for which means and variances were correlated, were log transformed (body length and body length/body width in females; body length, body length/pharynx length and position of the nerve ring in males). Missing data were replaced by the average value in a particular lineage.

Since specimens from the different localities were preserved by different methods (pictures or permanent slides), morphological data from each method were analysed and interpreted separately. A first DFA analysis involved all specimens (females and males,  $n = 46$  and  $n = 26$ , respectively) from the seven lineages which had been prepared in slides (Table 6.1). This yielded morphological information obtained from a vast geographical scale (Europe, Africa, USA). Subsequently, females and males were analysed separately so that sexually dimorphic and gender specific variables could be included in the DFA. We performed a third DFA which involved six lineages from a fairly small geographical area (ca. 100 km) in Belgium and The Netherlands that had been photographed digitally (Table 6.1). Lineage Z4 has not been observed in Belgium and The Netherlands, and hence, this lineage was not included in this last analysis. In addition, no males from Z and Z2 from Belgium and The Netherlands were available, so this last DFA was restricted to females.

No single morphometric character could unambiguously separate the species. Therefore, we created a polytomous key in which species are identified graphically by a combination of characters. Characters are chosen in accordance with the number of different frequency peaks found in their distribution range. The best characters to use at each step of the key have the highest number of peaks (= the highest variation) (Fonseca et al. 2006).

RESULTS

MOLECULAR DATA: PHYLOGENETIC ANALYSIS OF COI

The three methods of phylogenetic inference (MP, ML, BA) showed highly concordant tree topologies and divided the 58 mitochondrial COI sequences of *R. (P.) marina* into seven lineages and one terminal branch (Fig 6.1). The only difference

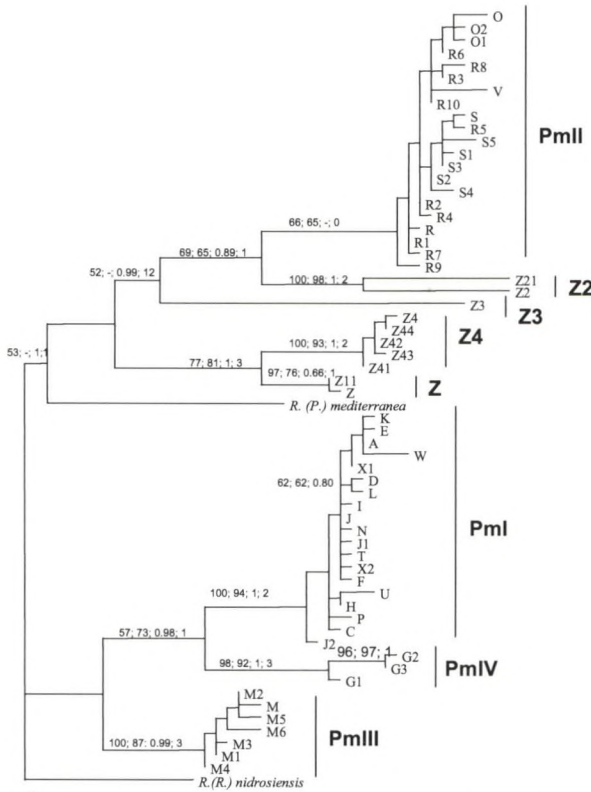

**Fig. 6.1:** *Rhabditis (Pellioditis) marina*. One of the 46 most parsimonious trees based on 396 bp of the mitochondrial COI gene. Values above branches are bootstrap supports from MP, ML, posterior probability values of BA and the number of fixed differences for each branch. Only bootstrap values above 50 are indicated. Lineages are indicated next to each branch. A dash indicates the absence of a branch in the respective analysis.

between MP, ML and BA was the inclusion of the Z2 haplotypes within the PmII lineage in BA, which explains the low bootstrap support of the PmII lineage (Fig 6.1). Within lineages, little or no substructure was observed. All Z haplotypes were pooled into three distinct lineages (Z, Z2 and Z4) and one terminal branch (Z3) with high bootstrap support and which were highly divergent from the known cryptic

lineages PmI, PmII, PmIII and PmIV (Table 6.3). The positioning of the sister species *R. (P.) mediterranea* remained unresolved, as were the deeper phylogenetic nodes. The clade containing *R. (P.) mediterranea*, PmII, Z, Z2, Z3 and Z4 contained one amino acid substitution (valine changed to leucine). Calculations of the transition/transversion ratio indicated that

transitions vastly outnumbered transversions (Table 6.4). Plotting the uncorrected pairwise distances against the ML distances for each codon position separately indicated that saturation occurred at the third codon position of the COI gene (data not shown). The number of fixed differences for each lineage is indicated above branches (Fig. 6.1). Only the PmII lineage did not contain any fixed differences. Divergence ranges were lower within lineages (0.2 – 2.3 %) than between lineages (3.5 – 10.6 %) (Table 6.3).

	PmI	PmII	PmIII	PmIV	Z	Z2	Z3	Z4	<i>R. (P.) mediterranea</i>	<i>R. (R.) nidrosiensis</i>
PmI	0.2 - 1.7	5 - 5.7	13.8 - 14.9	0.7 - 1.1	15.0 - 15.1	4.4	5.1 - 5.2	14.4 - 14.6	11.8 - 12.0	24.1 - 24.2
PmII	7.3 - 10.3	0.2 - 2.3	14.8 - 15.4	4.7 - 5.7	15.5 - 15.8	1.3 - 1.8	3.1 - 3.7	14.8 - 15.2	12.3 - 12.7	23.4 - 23.6
PmIII	6.8 - 8.3	7.8 - 10.3	0.2 - 1.3	13.8 - 15.0	12.9 - 13.8	14.6 - 14.8	14.7 - 14.9	12.9 - 13.4	10.1 - 10.6	23.9 - 24.2
PmIV	5.3 - 7.1	7.8 - 9.6	6.6 - 7.3	0.2 - 1.3	15.4 - 15.7	4.4 - 4.7	5.2 - 5.6	14.8 - 15.1	11.9 - 12.2	24.0 - 24.1
Z	8.8 - 10.6	6.3 - 8.1	6.6 - 7.1	7.8 - 8.3	0.2	15.5	15.8	5.0 - 5.2	11.3	24.9
Z2	9.3 - 9.8	4.1 - 5.5	8.5 - 9.1	9.1 - 9.3	7.3	0.4	2.7	14.8 - 14.9	11.8	23.4
Z3	8.8 - 9.6	6.3 - 8.5	8.8 - 9.8	9.3 - 9.6	8.1 - 8.3	8.5 - 8.8	-	15.2 - 15.6	12.2	23.5
Z4	8.5 - 9.6	6.6 - 8.5	6.8 - 7.8	8.8 - 9.6	3.5 - 4.3	7.3 - 7.5	9.3 - 9.8	0.2 - 0.4	10.8	24.2 - 24.3
<i>R. (P.) mediterranea</i>	9.3 - 10.6	7.5 - 9.1	7.1 - 7.8	9.1 - 9.6	6.3 - 6.5	8.5	9.8	8.3 - 8.5	-	24.6
<i>R. (R.) nidrosiensis</i>	7.3 - 8.5	7.5 - 9.6	7.5 - 8.1	8.3 - 8.5	8.8 - 9.1	9.1	11.1	7.8 - 8.1	8.8	-

**Table 6.3:** Sequence divergence among the molecular lineages in *R. (P.) marina*, and among *R. (P.) mediterranea* and *R. (R.) nidrosiensis*. Below diagonal are divergences based on COI, above diagonal based on ITS. Values on the diagonal are intralinesage divergence for the COI gene.

	COI	ITS		D2D3	ITS-D2D3
		90%	60%		
# taxa	62	32	32	33	30
Sequence length	396	669 - 858	669 - 858	579 - 589	1248 - 1603
Alignment length	396	913	913	597	1646
# unreliable positions	0	707	395	24	418
# parsimony informative sites	76 (19%)	24 (12%)	121 (23%)	41 (7%)	162 (13%)
Substitution model	K81uf + I + G	SYM + G	GTR + G	GTR + I + G	GTR + I + G
Tree length	247	77	297	156	455
# trees	46	15	3	3	4
Ts/Tv	2.5	1.34	1.92	3.17	2.24

**Table 6.4:** *Rhabditis (Pellioiditis) marina*. Summary of phylogenetic analyses for each gene separately and for the combined ITS-D2D3 dataset. Sequences of *Necator americanus* and *Ancylostoma caninum* are not considered in these calculations. Percentages indicate the threshold level used in SOAP for the ITS data.

MOLECULAR DATA: PHYLOGENETIC ANALYSES OF THE NUCLEAR ITS AND D2D3 REGIONS

MP, ML and BA of both nuclear genes were highly concordant and the ILD test allowed us to combine them into one dataset ( $p = 1$ , Fig. 6.2). The nuclear tree generally gave the same topology as the mitochondrial COI gene, the only difference was caused by the inclusion of the Z specimen within the Z4 lineage in the nuclear dataset, while it was a strongly supported monophyletic branch in the COI dataset.

Divergences between Z and Z4 were relatively low (Table 6.3, and 0 – 0.4 % in D2D3). Removing the Z specimen from the dataset yielded a non significant ILD test between the mitochondrial and nuclear dataset ( $p = 0.28$ ). The deeper nodes in the tree were well resolved in the nuclear tree, which supported the monophyly of the

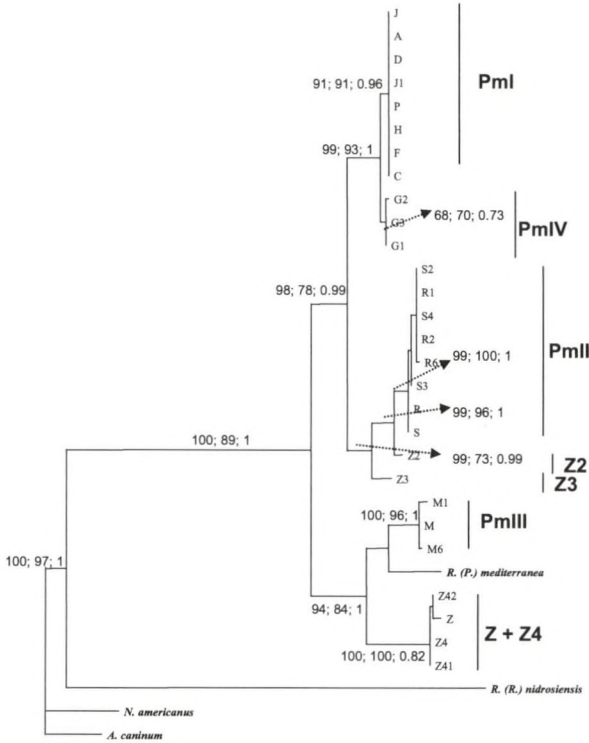

**Fig. 6.2:** *Rhabditis (Pellioiditis) marina*. One of the 7 most parsimonious trees of the combined nuclear ITS and D2D3 expansion segments. Values above branches (or indicated by arrow) are bootstrap support from MP, ML, and posterior probability values from BA. Only bootstrap values > 50 are indicated. Lineages are indicated next to each branch.

subgenus *Pellioiditis*. Within the 29 *Pellioiditis* sequences, the PmI, PmII, PmIII and PmIV lineages are again clearly separated and well supported (bootstrap > 90), except for lineage PmIV. The Z4 haplotypes are more closely related to the PmIII lineage and to *R. (P.) mediterranea* than to the other *R. (P.) marina* lineages. In addition, Z2 and Z3 form a monophyletic clade with the PmII lineage. They are, however, as divergent from each other as they are from the other lineages within the *Pellioiditis* group (Table 6.3). Finally, the PmI and PmIV lineage are considered sister taxa.

MORPHOLOGICAL ANALYSES

The DFA carried out on the complete dataset from slides (females + males) without sexual dimorphic (body length/body width) and gender-specific characters (spicule length, position of the vulva) separated most lineages in the first two roots (Fig 6.3). Root 1 was best explained by body length and separated three clusters: Z-Z2-PmIII, Z4-PmII and PmI-PmIV. Each lineage within these clusters was separated along root 2, except for lineages PmII-Z4 and Z-Z2. All interlineage squared

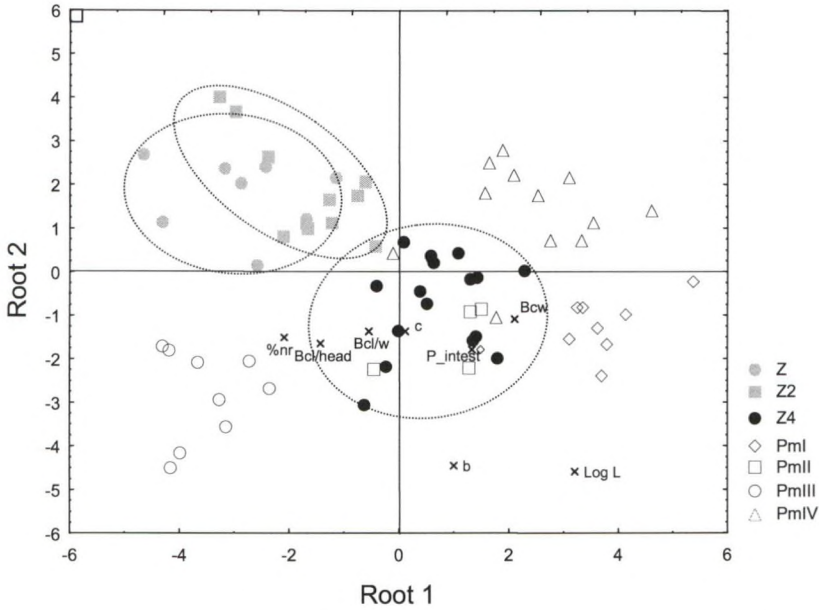
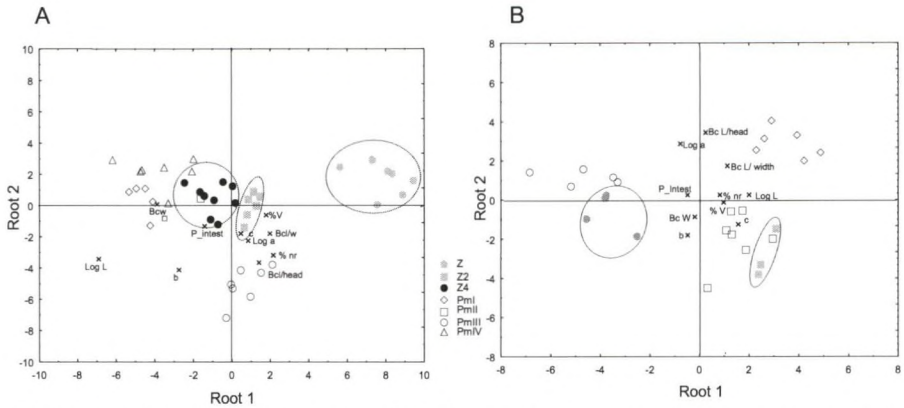

Fig. 6.3: *Rhabditis (Pellioiditis) marina*. Canonical scatterplot along the first two roots of morphological measurements in males and females which have been mounted in glycerine slides. The areas occupied by lineages Z, Z2 and Z4 are encircled. Variables included in the model are indicated with crosses. Abbreviations are as in Table 6.2.

Mahalanobis distances ( $D^2$ - values) were significantly different from zero ( $p < 0.01$  for all pairwise comparisons) except for lineages Z-Z2 ( $p = 0.05$ ).  $D^2$ -values ranged between 2.1 (Z-Z2) and 30.3 (PmIII-IV). When sexually dimorphic and gender-specific characters were included in the DFA, the canonical biplot of females separated lineages Z and Z2 from each other and from all other lineages along the first root (Fig. 6.4a). Z4 specimens clustered again with PmII, and  $D^2$ -values between PmII - Z4, PmII - PmI and PmII - PmIV were non significant at the  $p < 0.05$  level ( $D^2 = 24.9$ ,  $p = 0.14$ ;  $D^2 = 26.9$ ,  $p = 0.15$ ;  $D^2 = 30.3$ ,  $p = 0.08$ , respectively). However, this result should be interpreted with caution, as only two specimens of lineage PmII were available. All other  $D^2$  values were highly significant ( $p < 0.001$ , except for PmI-PmIV where  $p = 0.03$  and for PmII-Z2, where  $p = 0.009$ ) and ranged between 13.1 - 191.5. Based on measurements in males, all lineages were clearly separated in the first two roots of the canonical biplot (data not shown).  $D^2$ -values were high among all lineages and ranged between 45.3 - 721.5. They were non-significant only between Z-Z4 and Z-PmIII ( $p = 0.3$  and  $p = 0.1$ , respectively). However, this is most likely due to the small number of males ( $n = 2$ ) analysed in these lineages.





**Fig 6.4:** *Rhabditis (Pellioiditis) marina*. Canonical scatterplots along the first two roots of morphological measurements in females. A) Females mounted in slides and collected worldwide. B) Females photographed digitally and collected in Belgium and The Netherlands, without Z4 and PmIV. Z lineages are encircled. Variables included in the model are indicated with crosses. Abbreviations are as in Table 6.2.

Finally, we compared female morphometric data from pictures to infer variation in the observed morphological differentiation between lineages on a smaller geographical scale (100 km). For this analysis, we only considered populations between which gene flow was known to occur from a previous population genetic study (Derycke et al. 2006). The canonical biplot clearly separated lineages PmI, PmII and PmIII, while lineage Z clustered with lineage PmIII ( $D^2 = 15.4$ ,  $p = 0.27$ ) and lineage Z2 clustered with lineage PmII ( $D^2 = 11.5$ ,  $p = 0.52$ , Fig. 6.4b).

We subsequently compared our morphometric data from slides with data from the literature on rhabditid nematodes that have been observed on decomposing seaweeds (see Appendix 6.1). For *R. (R.) nidrosiensis*, morphometric data were available from several specimens, while we had minimum and maximum values for *R. (P.) marina*, *R. (P.) mediterranea*, *R. (P.) littorea* Sudhaus & Nimrich 1989 and *R. (P.) obesa* Gagarin 2001. The graphical polytomous key based on a combination of five characters (body length, tail length, buccal cavity length, body length/tail length and spicule length) unambiguously separated several species depending on the gender analysed (Fig. 6.5). For females, six species were clearly differentiated. The separation of PmII and *R. (P.) mediterranea* was less obvious, but in general, PmII specimens had a larger body length and a longer tail. Differences between the PmIII and Z4 specimens were absent in the first two steps of the key, but clear differences in buccal cavity width were observed (minimum-maximum values of 3 – 5  $\mu\text{m}$  vs 5 – 7  $\mu\text{m}$ , for PmIII and Z4 respectively). In addition, females of PmIII had a sharp conical

tail, while females of Z4 had a rounded tail tip (Appendices 5.4 and 6.2). For males, seven species could be differentiated with the first to steps of the key (Fig. 6.5 C, D). We have no data on the buccal cavity length of *R. (R.) nidrosiensis* and *R. (P.) obesa*, and consequently, both species are absent in Fig 6.5 D. Spicule length separated the remaining species, except for one outlier specimen of Z4 and *R. (P.) mediterranea* (Fig 5.5 E). Males from the latter species are distinguishable from Z2 and Z4 (and from the other lineages) by the absence of a structured bursa.

**Fig. 6.5:** Graphical polytomous key for identification of species within the *R. (P.) marina* species complex. A) Females from all species, body length vs. body length/ tail length; B) Females from the clustered species in A, tail length vs. buccal cavity length; C) Males from all species, body length vs. body length/tail length; D) males from the clustered species in C, tail length vs. buccal cavity length; E) Males from the clustered species in D, body length vs. spicule length.

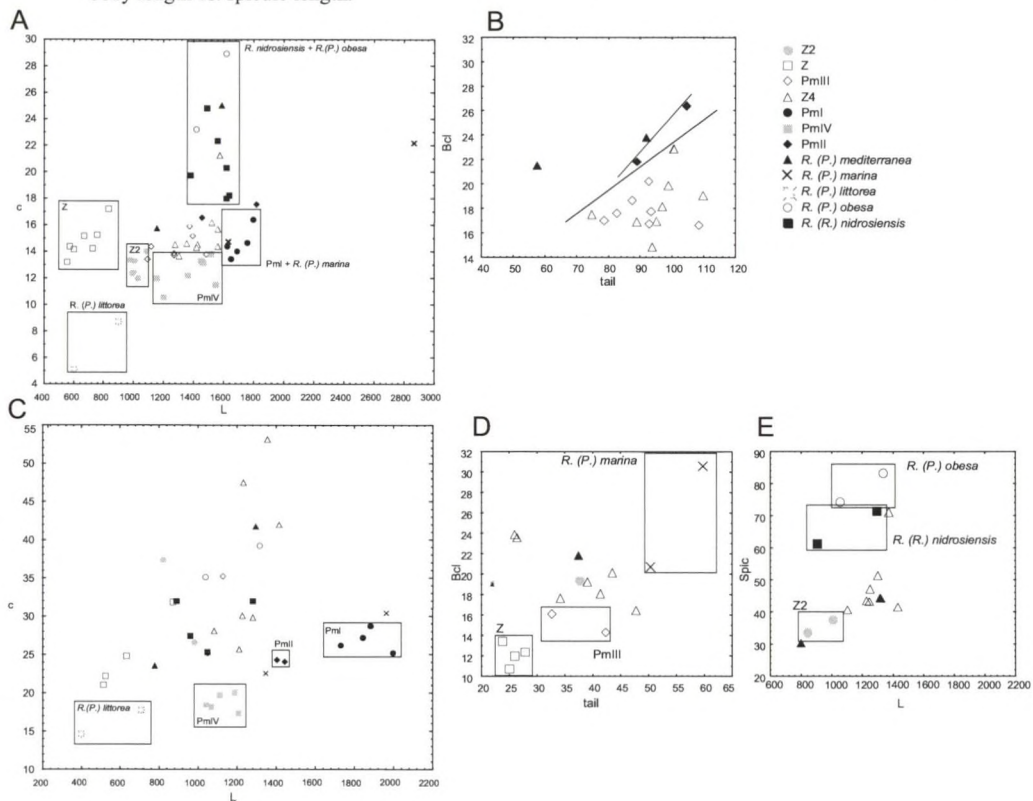

## DISCUSSION

*MOLECULAR RESULTS*

The phylogenetic analyses of three molecular loci (COI, ITS, D2D3) show highly concordant tree topologies with respect to the subdivision of *R. (P.) marina* individuals into several deeply divergent lineages. The few inconsistencies between the mitochondrial and the nuclear dataset are caused either by saturation effects (Dolphin et al. 2000) or by conflicting phylogenetic signals in both datasets (Sanderson & Shaffer 2002). Saturation (multiple substitutions at the same sites) masks the true levels of sequence divergence and obscures the deeper phylogenetic relationships among sequences (Arbogast et al. 2002). Several observations do in fact indicate that saturation is present in our mitochondrial COI data: 1) the inability of the COI dataset to infer deeper phylogenetic nodes, 2) the high number of transitions with respect to transversions at the third codon position, 3) the high bootstrap support situated only at the tips of the branches and 4) the differences between MP and ML bootstrap values (Page et al. 2005). In the present study, the principle cause of the conflicts between the nuclear and mitochondrial dataset are most likely differences in phylogenetic signal: after identifying the conflicting partition (the COI gene) and the problematic taxa (*Z* haplotype) by the “conditional combinability” method (Bull et al. 1993), a separate analysis of mitochondrial and nuclear fragments appeared the best approach for our data. In this way, we could infer recent phylogenetic relationships with inclusion of all taxa from the mitochondrial DNA, while the deeper nodes in the tree were resolved in the nuclear dataset.

Each lineage contains 2-17 fixed differences, this number differing between gene fragments. The COI gene is generally assumed to reach fixation four times more rapidly than the nuclear genome, because of its maternal inheritance and haploid state (Nadler 2002). From Table 6.5 the number of fixed differences per 100 bases is in most cases 1 – 6 times higher in the mitochondrial COI. Clearly, this number is strongly dependent on the number of individuals analysed in each lineage and further demonstrates the shortcomings of species delimitation based solely on fixed differences (Wiens & Servedio 2000). Sequence divergence is less susceptible to the number of specimens analysed, but seems too variable across taxa to be a good universal predictor for species delimitation (Ferguson 2002, Cognato 2006). Within

	COI	ITS	D2D3
PmI	0.51	0.76	0.00
PmII	0.00	0.38	0.00
PmIII	0.76	1.26	0.34
PmIV	0.76	0.13	0.00
Z	0.25	0.25	0.00
Z2	0.51	0.00	0.34
Z3	3.03	0.50	0.17
Z4	0.51	0.00	0.00
Total	6.31	3.28	0.84

**Table 6.5:** Number of fixed differences in COI, ITS and D2D3 genes per 100 bp, for each lineage.

the species complex investigated here, the lineages of *R. (P.) marina* are as divergent from each other as they are from their close relatives *R. (P.) mediterranea* and *R. (R.) nidrosiensis*. Divergent molecular lineages are not compatible with species if 1) extremely high rates of evolution are present in both mitochondrial and nuclear DNA, 2)

strong balancing selection is acting on the genome, or 3) vicariant events have occurred (Rocha-Olivares et al. 2001). Morphological differences were consistent with molecular results and hence, false conclusions due to high molecular rates can be discarded in our data. With respect to balancing selection, we find it unlikely that highly divergent polymorphisms in two independently evolving genomes would be maintained in the population. Balancing selection in the mitochondrial DNA genome in invertebrates has been associated with sex determination (Quesada et al. 1999), but this is unlikely here as relative frequencies of some lineages are not equally distributed across geographical regions (e.g. PmIV in Lake Grevelingen, Z4 in Mexico) (Rocha-Olivares et al. 2001). Finally, if the deeply divergent lineages are to be explained by vicariant events, they should be able to hybridize once they occur in sympatry. The monophyletic status of the lineages in the nuclear gene trees indicates that they do not hybridize. This is obviously disputable for lineages Z and Z4. Most likely, speciation between both lineages has occurred too recently to be detected in the nuclear genes.

#### MORPHOLOGICAL RESULTS

The set of morphological variables used in this study clearly demonstrates that the three Z lineages exhibit morphological differences with respect to each other and to the previously described lineages within *R. (P.) marina*. Regardless of which morphological variables are responsible for this differentiation, it shows that molecular lineages in free-living nematodes can be morphologically quite distinct. Similar observations have been made on parasitic nematodes (e.g. Carneiro et al. 1998, Han et al. 2006). Although different methodologies were applied to obtain

morphological data, our analyses strongly suggest that the morphological variation is affected by geographical scale, as the differences between some lineages were less pronounced or even disappeared when only specimens from geographically close populations were considered. Similar effects of geography on morphology in parasitic nematodes have been reported (Agudelo et al. 2005, Nguyen et al. 2006) and clearly illustrates the problem of morphological variability in nematodes.

Comparing our measurements from slides with those of *R. (P.) marina* reported in Sudhaus (1974) and of the congeners *R. (P.) mediterranea*, *R. (P.) ehrenbaumi*, *R. (P.) obesa* and *R. (P.) littorea* reported in the literature (Sudhaus 1974, Inglis & Coles 1961, Gagarin 2001 and Sudhaus & Nimrich 1989, respectively, Appendix 6.1) shows that our specimens are more similar to *R. (P.) marina* and *R. (P.) mediterranea* than to the other congeners. Moreover, the graphical polytomous key indicates that the combination of four morphometric characters (body length, tail length, buccal cavity length, spicule length) and one shape parameter (body length/tail length) is sufficient to differentiate all species. The three Z lineages show some similarities to, but clearly also differences from the *R. (P.) marina* and *R. (P.) mediterranea* described by Sudhaus (1974). *R. (P.) mediterranea* was initially described as a subspecies of *R. (P.) marina* due to its geographical distribution (Sudhaus 1974), and was later raised to species level mainly based on the female tail shape (Andrássy 1983, Sudhaus & Nimrich 1989). The high divergences between *R. (P.) mediterranea* and the *R. (P.) marina* lineages in both mitochondrial and nuclear fragments support this view.

COMBINING MOLECULAR AND MORPHOLOGICAL RESULTS TO INFER TAXONOMIC STATUS OF THE 'CRYPTIC' LINEAGES WITHIN *R. (P.) MARINA*

Inferring species status of the Z haplotypes requires a solid framework from which we can conclude whether the observed differences are situated at the intra- or interspecific level. For nematodes, evolutionary approaches are very promising for delimiting species as they produce phylogenetic relationships based on many characters (Adams 1998, 2001). Nevertheless, phylogenetic analyses of DNA sequences can easily lead to misinterpretations of the evolutionary processes underlying the observed patterns (Arbogast 2002, Nadler 2002). These theoretical drawbacks are substantially reduced when several independently evolving molecular

markers are analysed in the same set of individuals (Nadler 2002). We used concordant patterns among different markers as evidence for independent evolutionary histories of the four Z-lineages. The analyses of one mitochondrial and two nuclear genes yielded highly concordant tree topologies, indicating that the divergent phylogenetic lineages are caused by a common evolutionary process, i.e. speciation. Furthermore, at least three of the four lineages are accompanied by morphological differences. Although morphology may be influenced by geography, each of the lineages is differentiated from each other and from *R. (P.) marina* and *R. (P.) mediterranea* by a combination of morphometric characters and morphological observations (Fig 6.5). For example, lineages Z and Z4, which had similar nuclear gene sequences, are morphologically quite distinct. This clearly illustrates the usefulness of combining molecular and morphological data to delineate species. Furthermore, lineages Z and PmIII have been observed in very distant geographical populations (Belgium and South Africa, Belgium and USA, respectively), despite the limited dispersal of *R. (P.) marina*. This wide geographical distribution suggests that *R. (P.) marina* dispersal is not that limited at all or, alternatively, that parallel evolution may be acting in the *R. (P.) marina* complex. This clearly needs further research.<sup>23</sup>

---

<sup>23</sup> See Chapter IX

## CONCLUSION

Based on molecular and morphological data, we have identified eight species within the 'morphospecies' *R. (P.) marina*, of which four are new. We here refer to these species as Z, Z2, Z3 and Z4. Although nuclear sequences from Z were very similar to those of Z4, specimens belonging to both lineages were morphologically quite distinct. Our molecular data also confirms the species status of *R. (P.) mediterranea*. Most importantly, our results indicate that the true level of biodiversity in free-living nematodes is hitherto seriously underestimated. This study further illustrates the usefulness of a holistic approach for identifying species in problematic taxa. Obviously, more species are likely to be present within *R. (P.) marina* species complex, due to its cosmopolitan distribution. In view of this, we are currently collecting samples from over the world in order to further unravel the speciation modes in this cryptic species complex.

## ACKNOWLEDGEMENTS

S.D. acknowledges a grant from the Flemish Institute for the Promotion of Scientific- Technological Research (I.W.T.). G.F. is supported by the Brazilian ministry of science and technology (CNPq). T.M. is a postdoctoral fellow with the Flemish Fund for Scientific Research. Further financial support was obtained from Ghent University in BOF – projects 01GZ0705 and 011060002. The authors acknowledge Drs. Daniel Leduc who kindly provided specimens of *R. (P.) mediterranea* and are grateful to the following people for their help in collecting and retrieving samples of *R. (P.) marina*: Prof. Dr. G. Borgonie, Drs. S. Vandendriessche, G. Van Hoey and K. Houthoofd, Ms. H. Wydaeghe and Mr. T. Volant.



**Appendix 6.1:** Summary of morphometric data of all genetic lineages in *R. (P.) marina*. Literature data of *R. (P.) marina* (Sudhaus 1974) and of the congeners *R. (P.) mediterranea* (Sudhaus 1974), *R. (P.) nidrosiensis* (Inglis & Coles 1961), *R. (P.) littorea* (Sudhaus & Nimrich 1989) and *R. (P.) obesa* (Gagarin 2001) are included. Values are given in  $\mu\text{m}$  and as minimum – maximum (average).

		L	W	BcL	Ph	tail	a	b	c	%V	Spic	testis
FEMALES	Z	556 - 836 (675)	22 - 36 (29)	11 - 14(13)	127 - 177 (147)	39 - 51 (45)	20.1 - 24.9 (23.2)	4.3 - 4.9 (4.6)	13.2 - 17.2 (14.8)	54 - 57 (56)	-	-
	Z2	985 - 1088 (1018)	45 - 57 (49)	15 - 20 (17)	189 - 226 (202)	73 - 85 (79)	17.2 - 22.9 (20.8)	4.5 - 5.8 (5.1)	11.9 - 14.0 (12.9)	49 - 59 (54)	-	-
	Z4	1282 - 1573 (1447)	56 - 89 (64)	15 - 23 (18)	207 - 234 (221)	73 - 108 (94)	17.5 - 26.9 (22.6)	5.6 - 7.6 (6.5)	13.6 - 21.26 (15.4)	48 - 58 (51)	-	-
	PmI	1626 - 1798 (1705)	76 - 84 (81)	21 - 26 (23)	240 - 277 (256)	109 - 123 (117)	19.9 - 21.9 (20.9)	6.2 - 7.2 (6.7)	13.4 - 16.4 (14.6)	50 - 53 (52)	-	-
	PmII	1457 - 1818 (1638)	71 - 92 (81)	22 - 26 (24)	215 - 326 (270)	88 - 103 (95)	19.8 - 20.4 (20.1)	5.6 - 6.8 (6.2)	16.6 - 17.5 (17.0)	52 - 56 (54)	-	-
	PmIII	1095 - 1514 (1309)	42 - 60 (54)	16 - 20 (18)	183 - 203 (192)	77 - 107 (90)	21.0 - 28.6 (24.1)	5.8 - 7.7 (6.7)	13.4 - 15.9 (14.3)	50 - 53 (51)	-	-
	PmIV	1160 - 1548 (1387)	51 - 76(64)	19 - 24 (21)	220 - 245 (235)	97 - 134 (112)	18.9 - 24.5 (21.8)	5.1 - 6.6 (5.9)	10.5 - 13.8 (12.3)	47 - 53 (50)	-	-
	<i>P. mediterranea</i>	1157 - 1590	45 - 78	22 - 24	197 - 237	56 - 91	18.2 - 25.8	5.2 - 7.0	15.7 - 25.0	51 - 55	-	-
	<i>P. marina</i>	1628 - 2875	69 - 118	30-39	237 - 354	99 - 139	20 - 24.5	5.2 - 8.1	14.7 - 22.0	53 - 57	-	-
	<i>P. ehrenbaumi</i>	1380 - 1640	-	-	-	-	14.9 - 20.3	3.6 - 4.2	18.0 - 24.8	52 - 56	-	-
<i>P. littorea</i>	599 - 900(731)	34 - 58 (46)	16 - 20 (18)	118 - 156 (137)	89 - 147 (113)	14.4 - 17.8 (15.9)	4.7 - 6.4 (5.3)	5.1 - 8.7 (6.4)	47 - 53 (50)	-	-	
<i>P. obesa</i>	1422 - 1619 (1524)	-	-	361-416 (387)	52-59 (56)	-	16.0 - 20.0 (19)	23.2 - 28.9 (25.6)	57 - 59 (58)	-	-	
MALES	Z	515 - 870 (635)	25 - 34 (29)	10 - 13 (12)	115 - 155 (133)	23 - 27 (25)	15.6 - 25.1 (21.5)	4.3 - 5.6 (4.7)	21.0 - 31.8 (24.9)	-	30 - 35 (33)	338 - 669 (461)
	Z2	822 - 985 (904)	43 - 53 (48)	19 - 19 (19)	166 - 179 (173)	22 - 37 (29)	15.4 - 22.7 (19.1)	4.9 - 5.5 (5.2)	26.5 - 37.3 (31.9)	-	34 - 38 (36)	655 - 823 (739)
	Z4	1084 - 1413 (1258)	48 - 71 (55)	16 - 24 (20)	186 - 226 (201)	25 - 47(36)	19.1 - 25.2 (22.9)	5.4 - 7.3 (6.3)	25.7 - 53.1 (36.6)	-	41 - 52 (48)	983 - 1233 (1101)
	PmI	1731 - 1998 (1864)	72 - 87 (79)	24 - 28 (26)	297 - 312 (304)	65 - 79 (69)	21.4 - 27.7 (23.6)	5.7 - 6.4 (6.1)	25.2 - 28.7 (26.8)	-	50 - 54 (53)	1205 - 1555 (1316)
	PmII	1403 - 1445 (1424)	62 - 62 (62)	23 - 23 (23)	260 - 280 (270)	57 - 60 (58)	22.6 - 23.16 (22.9)	5.0 - 5.6 (5.3)	24.0 - 24.3 (24.2)	-	57 - 64 (61)	1168 - 1238 (1203)
	PmIII	1051 - 1130 (1090)	39 - 32 (36)	14 - 16(15)	179 - 163 (171)	32 - 41 (36)	28.4 - 32.5 (30.5)	6.3 - 6.4 (6.4)	25.1 - 35.2 (30.2)	-	37 - 42 (40)	885 - 948 (917)
	PmIV	1043 - 1210 (1125)	47 - 62 (54)	18 - 20 (19)	202 - 227 (213)	56 - 70 (60)	18.9 - 21.9 (20.6)	4.9 - 5.5 (5.3)	17.3 - 20.0 (18.7)	-	52 - 62 (57)	909 - 1078 (996)
	<i>P. mediterranea</i>	779 - 1298	32 - 49	19 - 22	153 - 200	22 - 37	18.7 - 33.2	4.4 - 6.6	23.6 - 41.7	-	31 - 45	-
	<i>P. marina</i>	1337 - 1978	43 - 71	21 - 31	221 - 291	50 - 59	20.9 - 32.4	4.6 - 7.7	22.4 - 30.2	-	37 - 57	-
	<i>P. ehrenbaumi</i>	890 - 1280	52 - 69	-	217 - 312	27 - 40	17.0 - 18.3	3.2 - 4.1	25.3 - 32.0	-	-	-
<i>P. littorea</i>	400 - 708 (501)	25 - 45 (33)	15 - 20 (16)	109 - 159 (125)	25 - 33 (28)	13.6 - 19.9 (16.3)	3.5 - 4.8 (3.9)	14.6 - 17.8 (16.2)	-	23 - 30 (26)	201 - 453 (286)	
<i>P. obesa</i>	1039 - 1318 (1116)	-	-	322 - 357 (340)	28 - 37 (32)	-	11.0 - 19.0 (16)	35.1 - 39.2 (37.1)	-	75 - 84 (79)	-	

Appendix 6.2. Drawings of the *Rhabditis (Pellioiditis) marina* species complex. a-c: Z2; d-f: Z; g-i: Z4

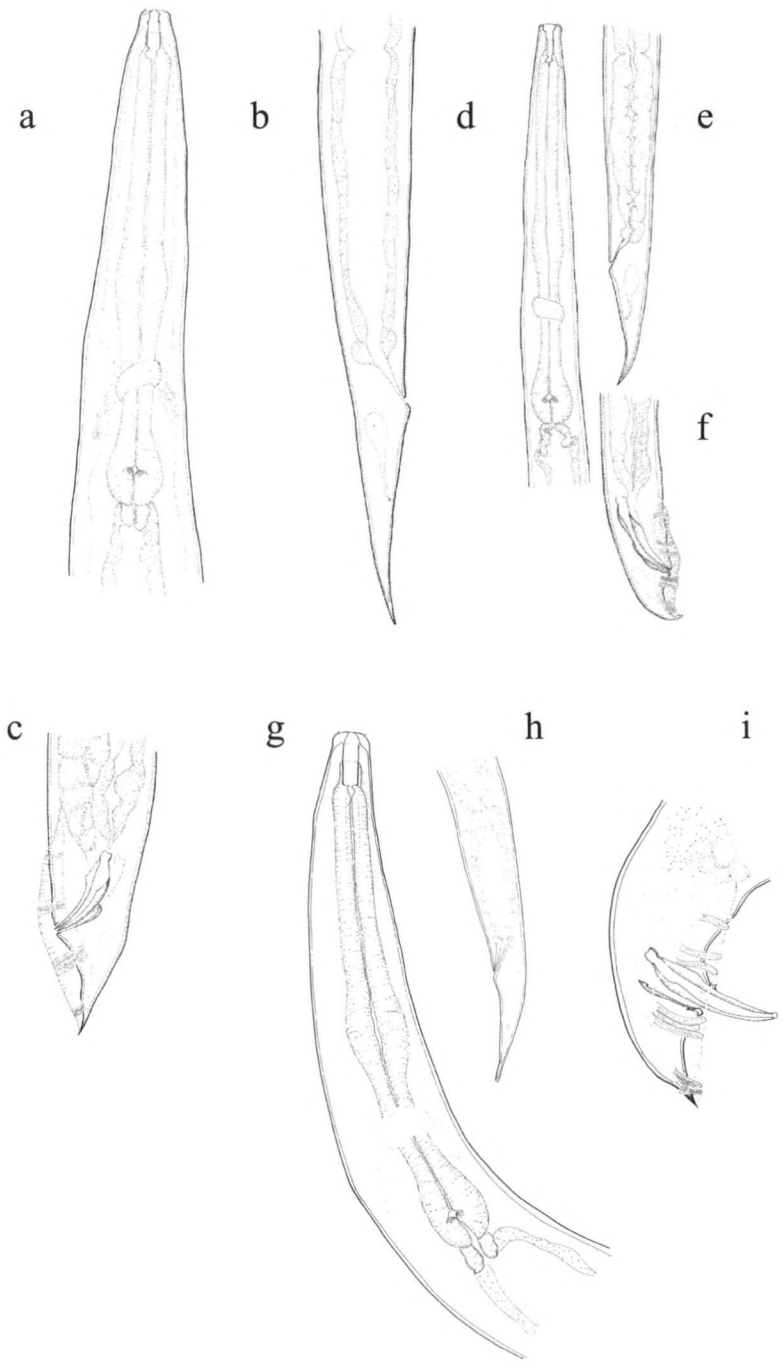

118971

---

CHAPTER VII

COLONISATION PATTERNS OF NEMATODA ON  
DECOMPOSING ALGAE IN THE ESTUARINE ENVIRONMENT:  
COMMUNITY ASSEMBLY AND GENETIC STRUCTURE OF THE  
DOMINANT SPECIES *PELLIODITIS MARINA*

---

Published as:

Derycke S , Van Vynckt R , Vanoverbeke J , Vincx M , Moens T (2007)  
Colonisation patterns of Nematoda on decomposing algae in the estuarine  
environment: community assembly and genetic structure of the dominant  
species *Pellioditis marina*. **Limnol Oceanogr** 52 (3), in press.

**ABSTRACT**

We performed a field experiment in the Westerschelde estuary (The Netherlands) to characterize the colonisation dynamics of nematodes in relation to the proximity of a source population and to local environmental conditions. The effects of colonisation on the population genetic structure of the dominant species, *Pellioiditis marina*, were simultaneously investigated. Two contrasting sites, each containing four patches with defaunated algae, were sampled seven times during one month. Site A was situated amidst *Fucus* stands which permanently harbor *P. marina*, while site B was approximately 100 m from any source population and experienced more stressful environmental conditions. We hypothesized that 1) colonisation in site A would proceed faster than in site B, and that 2) founder events and genetic bottlenecks would affect population genetic structure and differentiation at site B more than at site A. We screened 992 individuals for variation in 426 bp of the cytochrome oxidase c subunit 1 gene with the single strand conformation polymorphism method. The algal deposits at site A were indeed more rapidly colonized and reached fivefold higher densities of nematodes than those in site B. Haplotype composition in site A was very similar to that of the source population, while rare haplotypes were abundant and genetic diversity was lower in site B. We conclude that founder effects and genetic bottlenecks structured the populations in site B. The genetic differences between patches in each site further indicate that effective migration in *P. marina* is low and that priority effects influence the genetic structure of *P. marina* populations.

## INTRODUCTION

A variety of marine meiobenthic organisms, such as gastrotrichs and nematodes, have a seemingly cosmopolitan distribution despite a lack of spawning, pelagic larvae and/or other dispersal stages (Coomans 2000). Nevertheless, passive dispersal of meiofauna can be substantial. Nematodes, for instance, are frequently observed in the water column, especially in areas with high tidal activity (Ullberg & Olafsson 2003), and appear to be among the most abundant rafting organisms (Thiel & Gutow 2005). Moreover, several meiofaunal taxa have relatively low abundances in the sediment, but abound in epiphytic habitats or on macroalgal and other wrack deposits. In these microhabitats, they are more prone to resuspension and consequently to passive transport (Bouwman et al. 1984; Warwick 1987; Alkemade et al. 1994). Based on these observations, it can be hypothesized that species living on wrack deposits have high dispersal abilities and should consequently show little isolation among populations.

Within the Nematoda, typical representatives on stranded algae belong to the families Monhysteridae and Rhabditidae (Warwick 1987). One of the first colonizers of new macroalgal deposits is the rhabditid nematode *Pellioiditis marina*. This sexually reproducing, oviparous to ovoviviparous species has a high reproductive output, a short generation time (down to 3 days under optimal conditions, Moens & Vincx 2000) and can raft on floating algae (Derycke, pers obs), suggesting effective dispersal. Nevertheless, a pronounced population genetic structure has been found in *P. marina* on a local scale (40 km, Derycke et al. 2005). Such lack of correlation between dispersal capacity and genetic differentiation has also been observed in small crustaceans in lentic habitats and has been explained by limited effective long-distance dispersal (Brendonck et al. 2000), persistent founder effects (Boileau et al. 1992) and/or local adaptation (De Meester et al. 2002). We have also observed temporal differences in haplotype frequencies suggesting that population genetic structure in *P. marina* is caused by metapopulation dynamics (Derycke et al. 2006). Indeed, macroalgal wrack is irregularly deposited near the high water line and therefore provides a patchy, fragmented habitat. These deposits break down due to dehydration, ageing and fragmentation, the rates of which are highly variable and are influenced by site- and time-specific environmental conditions (Colombini & Chelazzi 2003). For example, an *in situ* litterbag experiment at the sites and

environmental conditions of the present study showed that *Fucus* thalli lost approximately 50 % of their carbon and 60 % of nitrogen within 30 days; the associated fauna was dominated by nematodes even after 85 days in situ (Moens T., unpubl. data). Furthermore, interspecific interactions and priority effects may influence the nematode community composition once the algae are stranded. Finally, the colonisation of stranded deposits is also largely influenced by stochastic factors (Ekschmitt & Griffiths 1998).

Although there is a solid theoretical framework explaining the ecological and evolutionary consequences of local colonisation and extinction in metapopulations (e.g Harrison & Hastings 1996, Hanski & Gilpin 1997), including the effect on genetic differentiation among and within demes within a metapopulation (Slatkin 1977, Wade & McCauley 1988, Whitlock & McCauley 1990), empirical studies in natural environments are still quite scarce (Whitlock 1992, Saccheri et al. 1998; Aars et al. 2006), especially in the marine environment. Theory indicates that the amount of genetic differentiation among demes within a metapopulation is largely dependent upon the mode of founding of new demes within that metapopulation (Wade & McCauley 1988): large propagules with individuals from many demes will cause little genetic differentiation within the metapopulation. In contrast, a small number of colonizers originating from one or a few demes will enhance genetic differentiation within the metapopulation as a result of genetic bottlenecks. Since ephemeral habitats are short-lived, allele frequencies within the demes of the metapopulation are not expected to be homogenized by gene flow (Whitlock & McCauley 1990), especially if priority effects are involved.

The main focus of the present paper is to investigate the colonisation dynamics of *Pellioiditis marina* on empty algal patches and to characterize the genetic structure of the founder populations at two sites in Paulina saltmarsh (Westerschelde Estuary, The Netherlands). Patches of defaunated algae were incubated amidst (site A) and at least 100 m away (site B) from the nearest source population of nematodes. The source population is characterized by the permanent availability of *Fucus* stands, which can act as a 'mainland' population. Distance from the source population was not, however, the only major difference between both experimental sites: environmental conditions at site B were more variable and stressful because of the higher elevation above sea-level and consequently longer exposure time during low tide. We expected that 1) patches in site A would be colonized more quickly than

patches in site B due to their closer proximity to a source population, that 2) genetic variation within patches in site B would be smaller than genetic variation within patches in site A as a result of genetic bottlenecks due to the larger distance to the source population and the more stressful conditions at site B, that 3) on average, genetic differentiation between patches in site B and the source population would be higher than between patches in site A and the source population as a result of founder events and that 4) genetic differences among patches in site B would be larger than among patches in site A due to priority effects preventing additional colonisation after the arrival of the first colonizers.

## MATERIAL AND METHODS

### EXPERIMENTAL SETUP AND SAMPLING

Colonisation of defaunated algal deposits was investigated at two different sites (A and B) along the edges of the Paulina salt marsh, which is in the polyhaline reach of the Westerschelde estuary (The Netherlands). Site A was in proximity (< 5 m) of living *Fucus* thalli where *P. marina* occurs year-round, while site B lacked *Fucus* stands or other suitable substrata for *P. marina*. The *Fucus* stand nearest site B was ca. 100 m downstream and less elevated than site A. Because of their relative position, passive transport of algae from the nearby stand to site B was mainly dependent on wind direction and was probably very limited during our experiment. Other 'permanent' *P. marina* populations were about 1 km or more from site B. *Fucus* and other organic material, however, are episodically washed ashore, the amounts and frequency largely depending on wind force and direction. Therefore passive dispersal from such sources could also occur in site B.

*Fucus* thalli, collected from another location in the Westerschelde estuary (Kruispolderhaven), were defaunated by submerging the thalli in tap water and incubating them overnight at 35 °C. The combination of freshwater and high temperature is lethal to marine and brackish-water nematodes within minutes to hours (Moens T., pers obs.). After treatment, all thalli were additionally rinsed with tap water to remove dead meiofauna.

Four algal deposits (1 m x 0.6 m, containing algae up to a volume of 10 l) were fixed at each site with agricultural fencing wire (mesh diameter 1 mm) during

low tide on 01 October 2004. The defaunated algae were distributed equally among and within these fencing wires. Distance between algal deposits within a site averaged two meters, while site A and B were approximately two kilometers apart. In this way, the four algal deposits within a site were considered replicates (A1 - A4 and B1 - B4).

Samples were taken after two and five days in situ, and subsequently every fifth day for one month (30 days). Site B was also sampled after 35 days because colonisation started later than in site A (see results). This period was long enough for *P. marina* to produce up to 7 generations, as its generation time is < 5 days under the prevailing climatic conditions of our experiment (Moens & Vincx 2000). On each sampling occasion, *Fucus* fragments were haphazardly collected from different parts and layers within each patch, and pooled until a volume of 100 ml (ca. 30 g wet algae) was obtained.

### PROCESSING OF FUCUS THALLI

On each sampling occasion, a small amount of *Fucus* (ca. 4 g wet weight) was rinsed with tap water, dried, homogenized and weighed for carbon and nitrogen analysis on a Carlo-Erba elemental analyzer type NA-1500 to document the decomposition process of the algae. The remaining algal fragments (ca. 26 g wet weight) were incubated on agar slants (salinity of 25, 0.7 ‰ and 10:1 Bacto:Nutrient agar, Moens & Vincx 1998). Nematodes were subsequently allowed to colonize the agar for two days, which is less than the shortest generation time of *P. marina* under optimal conditions (Vranken & Heip 1983, Moens & Vincx 2000). This procedure greatly facilitates identification and isolation of *P. marina* under a dissecting microscope. For the first two sampling periods, all specimens observed on the agar were isolated (day 2: average  $n = 2.7$  for site A and  $n = 0$  for site B and day 5: average  $n = 17$  for site A and  $n = 4.6$  for site B). From day 10 onwards, approximately 30 mature *P. marina* were handpicked from each sample, transferred to sterile water and preserved in acetone for molecular analyses.

### NEMATODE COMMUNITY

From day 10 onwards, nematodes became abundant on the algae in the field, and additional *Fucus* thalli (ca. 5 g wet weight) were collected from each patch to analyse the nematode community composition. These fragments were thoroughly



rinsed with tap water over a 38  $\mu\text{m}$  sieve and nematodes were preserved in 4 % buffered formaldehyde, stained with Rose Bengal and then counted under a dissecting microscope. *Pellioiditis marina* was counted in three patches from each site for each date. Other nematode genera were identified by randomly handpicking 100 specimens from the preserved samples and mounting them on Cobb slides according to Vincx (1996). This community analysis was performed on three patches from each site at days 10, 20 and 30 of the experiment. When less than 100 specimens were present in a sample, all nematodes were handpicked (mainly site B). The *Fucus* fragments from which nematodes were counted and identified were subsequently dried at 60 °C and weighed until a stable dry weight was obtained (usually > 4 days). This dry weight was used to standardize nematode counts among samples.

#### MOLECULAR ANALYSIS OF *P. MARINA*

To investigate the dynamics of the genetic composition of *P. marina* populations at both sites, genetic variation was assessed in approximately 30 *P. marina* individuals (except for days 2 and 5, see above) from each of three patches per site and date. Genetic diversity in a 426 bp long fragment of the mitochondrial deoxyribonucleic acid (mitochondrial DNA) cytochrome oxidase c subunit 1 (COI) gene was screened using the Single-Strand Conformation Polymorphism (SSCP) method. Because of the high variability among patches in site B, we decided to also analyse a fourth replicate from site B. For a detailed description of the DNA extraction protocol, Polymerase Chain Reaction (PCR) amplification, SSCP-conditions and sequencing strategy see Derycke et al. (2005). PCR products were amplified with primers JB3 and JB5. Different SSCP-profiles were sequenced with the aforementioned primers, and the most abundant haplotypes in each site were sequenced several times to confirm the SSCP-band mobility and sequence variability. Sequences can be found in GenBank under accession numbers AJ867447-AJ867457 and AJ867477-AJ867478 (Derycke et al. 2005).

### DATA ANALYSIS

#### Fucus quality and nematode abundance

A univariate repeated-measures analysis of variance (ANOVA) was performed to evaluate whether C- and N- content of the *Fucus* thalli, absolute nematode abundances, and the relative abundance (%) of *P. marina* changed over time between sites A and B. When the data did not fulfil the assumptions for parametric tests (normality, homogeneity of variances), they were transformed (absolute nematode abundances per g dry weight were log transformed, carbon content was arcsine transformed). All univariate tests were performed with the Statistica 6.0 program (Statsoft, 2001).

#### Nematode community

Differences in taxon composition between sites A and B were analysed with the software package Primer v.5.2.9 (Clarke & Gorley 2001). Absolute abundance data were double root transformed to down-weight the importance of the highly abundant genera *Pellioditis* and *Geomonhystera*. Similarity among all pairs of patches was assessed by calculating the Bray-Curtis coefficient and was visualised in a non-metric multidimensional scaling plot (nMDS). Differences among sites A and B were analysed by a two-way crossed ANOSIM test, allowing for the fact that there were changes over time. Significance levels were assessed by a permutation procedure (Clarke & Gorley, 2001). Similarity percentage (SIMPER) analysis was performed to identify the taxa that account for similarity within, and dissimilarity among sites A and B.

#### Genetic patterns and diversity of *P. marina*

Haplotype diversity ( $h$ , Nei 1987) was calculated for each patch and compared among sites and time by means of a repeated measure ANOVA in Statistica 6.0 (Statsoft, 2001). The data were arcsin transformed, but variances were not homogeneous for one time variable. Nevertheless, we used the repeated-measurements ANOVA because there is no non-parametric alternative for the repeated measures ANOVA, and because the non-homogeneity of variances was only borderline significant ( $p = 0.032$ ).

Genetic differentiation within sites A and B was assessed by means of a hierarchical AMOVA (analysis of molecular variance) for each site as implemented in the Arlequin v. 2.0 software package (Schneider et al. 2000). Absolute haplotype frequencies from each date were grouped according to patch. This resulted in three and four groups for sites A and B, respectively.

Subsequently, we used the absolute haplotype frequencies of *P. marina* in site A obtained from a previous study covering four consecutive seasons (Derycke et al. 2006) to characterize the source population. Genetic differences between this source population and sites A and B were investigated by calculating pairwise  $F_{st}$  values in Arlequin v 2.0 using haplotype frequencies of the last sampling day (day 30 for site A, day 35 for site B) in each patch. All  $F_{st}$  values calculated between the source population and patches from site A, and between the source population and patches from site B, were subsequently grouped. We then performed a non-parametric Mann-Whitney  $U$ -test to address differences between groups. We also calculated  $F_{st}$  values between each patch within sites by summing all haplotype frequencies over time in each patch. Because the data per patch are not independent (cf. repeated sampling from the same unit), we used a permutation test ( $n = 1000$ ) in Fstat v.2.9.3. (Goudet 2001) to assess whether  $F_{st}$  values among patches differed significantly between sites.

### Colonisation dynamics of haplotypes

The colonisation dynamics of haplotypes over time were investigated in two ways. First, we calculated Bray-Curtis similarity coefficients of absolute haplotype frequencies between the onset of the experiment (days 2, 5, and 10) and day 30 for site A and between days 5, 10, 15, 20, and day 35 for site B for each patch separately. Frequencies were double root transformed to down-weight the importance of the highly abundant haplotypes (A, D, and F) and standardized for each sampling date within each patch. Second, we investigated whether the relative abundances of haplotypes at the start (i.e. day 2 for A1 and A3, day 5 for A2 and B1, day 10 for B4, day 15 for B3 and day 20 for B2) were positively correlated with their relative abundances at day 30 (or day 35). The non-parametric Spearman rank correlation analysis (Statistica 6.0) was performed for each patch within each site. A positive correlation indicates that the first haplotypes arriving at each site constitute a major part of the population build up by the end of the experiment.

## RESULTS

*FUCUS* QUALITY

Carbon and nitrogen content of *Fucus* thalli varied between 29.9 - 37.1 % and 1.44 - 1.74 %, respectively. After an initial decrease, carbon and nitrogen remained fairly constant at both sites (carbon:  $F_{7,42} = 2.28$ ,  $p = 0.045$ ; nitrogen:  $F_{7,42} = 0.48$ ,  $p = 0.84$ ). The borderline significance of the carbon dynamics reflected fluctuations at site B during days 10 to 20 rather than differences in carbon dynamics among sites (data not shown). N-content was significantly higher at site A (site effect:  $F_{1,6} = 7.84$ ,  $p = 0.03$ ), suggesting that *Fucus* thalli were less decomposed than at site B because nitrogen content correlates well with the decomposition of organic material (De Mesel 2004). This was, however, at odds with our observations in the field: *Fucus* thalli incubated in site A changed colour more rapidly, were clearly covered by microbial films and were more fragmented, the latter probably caused by the activity of crabs. The differences in N-content and decomposition dynamics between both sites are most likely caused by abiotic factors such as humidity (Newell et al. 1985) and tidal differences (Halupa & Howes 1995), since site B was located higher above sea-level and was consequently inundated for shorter periods than site A.

## NEMATODE ABUNDANCES

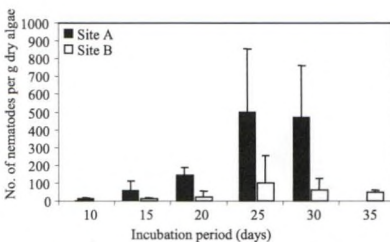

**Fig. 7.1:** Total number of nematodes per gram of dried *Fucus* thalli from day 10 onwards. Columns are averages of three patches and error flags are standard deviation across three patches.

Nematode counts were standardized per g dry weight of *Fucus*. *Fucus* incubated in the proximity of algae (site A) yielded a five-fold higher nematode density than *Fucus* incubated at site B (site effect:  $F_{1,4} = 12.14$ ,  $p = 0.025$ , Fig. 7.1). Nematode abundances increased during the first 20-25 days of the experiment (time effect:  $F_{4,16} = 17.42$ ,  $p < 0.001$ ) and subsequently stabilized (Fig. 7.1).

This did not, however, result in a significant time x site interaction ( $F_{4,16} = 0.48$ ,  $p = 0.74$ ), indicating that the pattern of increase was similar in both sites.

NEMATODE COMMUNITY

In total, 25 genera were found on the incubated algae during the course of the experiment, 16 of which were present after 10 days of incubation. Of these 16 genera, 15 were present at site A and 10 occurred at site B (Table 7.1). The average number of genera observed during the course of the experiment was similar in both sites (14 in site A and 13 in site B). The developing nematode communities were dominated by the genera *Pellioditis* and *Geomonhystera* (Fig. 7.2a and Table 7.1). This dominance was

Feeding group	Genus	Site A		Site B		Site A		Site B		Site A		Site B	
		10 days incubation				20 days incubation				30 days incubation			
		Average	SD	Average	SD	Average	SD	Average	SD	Average	SD	Average	SD
1	<i>Desmolaimus</i>	-	-	-	-	-	-	0.3	0.5	-	-	-	-
1	<i>Diplolaimella</i>	-	-	-	-	-	-	-	-	-	-	0.5	0.9
1	<b><i>Geomonhystera</i></b>	<b>5.6</b>	<b>1.3</b>	<b>0.1</b>	<b>0.2</b>	<b>43.0</b>	<b>18.8</b>	<b>0.8</b>	<b>0.1</b>	<b>88.6</b>	<b>21.0</b>	<b>9.8</b>	<b>6.5</b>
1	<i>Gnomoxyala</i>	-	-	-	-	0.7	1.2	-	-	-	-	-	-
1	<b><i>Monhystera</i></b>	<b>0.3</b>	<b>0.3</b>	<b>0.3</b>	<b>0.4</b>	<b>4.5</b>	<b>3.0</b>	<b>1.4</b>	<b>0.5</b>	<b>11.5</b>	<b>6.7</b>	<b>0.7</b>	<b>1.2</b>
1	<i>Panagrolaimus</i>	0.3	0.3	-	-	0.7	1.2	-	-	1.8	3.1	0.7	0.8
1	<b><i>Pellioditis</i></b>	<b>1.5</b>	<b>2.6</b>	<b>0.1</b>	<b>0.2</b>	<b>76.8</b>	<b>19.2</b>	<b>9.8</b>	<b>16.4</b>	<b>346.6</b>	<b>294.0</b>	<b>37.8</b>	<b>44.7</b>
1	<i>Rhabditidae</i>	-	-	-	-	-	-	-	-	-	-	0.6	1.0
<b>Total bacterial feeders</b>		<b>7.7</b>	<b>4.5</b>	<b>0.5</b>	<b>0.9</b>	<b>125.7</b>	<b>43.4</b>	<b>12.3</b>	<b>17.5</b>	<b>448.5</b>	<b>324.8</b>	<b>50.0</b>	<b>55.1</b>
2	<i>Chromadora</i>	0.2	0.3	0.1	0.2	-	-	0.9	1.5	-	-	2.9	4.1
2	<i>Chromadorina</i>	0.3	0.2	0.1	0.2	-	-	0.6	1.0	-	-	3.1	5.3
2	<b><i>Daptonema</i></b>	<b>0.9</b>	<b>0.7</b>	-	-	<b>4.7</b>	<b>0.7</b>	<b>2.1</b>	<b>1.9</b>	<b>10.5</b>	<b>11.8</b>	-	-
2	<b><i>Metachromadora</i></b>	<b>0.6</b>	<b>0.7</b>	<b>0.1</b>	<b>0.2</b>	<b>1.6</b>	<b>0.5</b>	<b>0.7</b>	<b>1.3</b>	-	-	-	-
2	<i>Microlaimus</i>	0.3	0.2	0.1	0.2	1.1	1.9	0.3	0.5	-	-	-	-
2	<i>Neochromadora</i>	0.5	0.5	-	-	1.0	1.0	-	-	0.9	1.6	0.5	0.9
2	<i>Paracanthochus</i>	-	-	-	-	0.4	0.6	0.3	0.5	-	-	-	-
2	<i>Paracyatholaimus</i>	-	-	-	-	0.4	0.6	1.5	2.5	-	-	1.0	1.8
2	<i>Ptycholaimellus</i>	-	-	-	-	1.3	2.3	-	-	1.1	1.9	0.3	0.5
2	<i>Spilophorella</i>	0.5	0.5	-	-	-	-	-	-	-	-	-	-
2	<i>Theristus</i>	-	-	-	-	1.4	1.7	2.0	3.5	6.5	8.9	1.3	1.6
2	<i>Tripyloides</i>	0.1	0.2	-	-	1.1	1.8	1.5	2.5	0.9	1.6	-	0.0
<b>Total unicellular eukaryote feeders</b>		<b>3.3</b>	<b>3.1</b>	<b>0.4</b>	<b>0.8</b>	<b>13.0</b>	<b>11.1</b>	<b>9.9</b>	<b>15.2</b>	<b>19.9</b>	<b>25.9</b>	<b>9.1</b>	<b>14.1</b>
3	<i>Calyptronema</i>	0.2	0.3	0.1	0.2	1.6	2.9	0.6	1.0	-	-	-	-
3	<i>Eurystomina</i>	0.2	0.3	-	-	-	-	-	-	-	-	-	-
3	<i>Oncholaimus</i>	-	-	-	-	0.7	1.2	0.3	0.5	1.1	1.9	-	-
3	<i>Syringolaimus</i>	-	-	0.1	0.2	-	-	1.2	2.0	-	-	2.5	4.4
<b>Total carnivores</b>		<b>0.3</b>	<b>0.5</b>	<b>0.2</b>	<b>0.3</b>	<b>2.3</b>	<b>4.0</b>	<b>2.0</b>	<b>3.5</b>	<b>1.1</b>	<b>1.9</b>	<b>2.5</b>	<b>4.4</b>
4	<i>Hirschmanniella</i>	0.5	0.5	0.1	0.2	2.1	1.1	-	-	-	-	-	-

**Table 7.1:** Nematode genera occurring at sites A and B after 10, 20, and 30 days incubation. Densities are calculated as the number of individuals per gram dry weight of *Fucus* and are averages of three replicates. Feeding group refers to the dominant feeding type in each genus, which is: (1) bacterial feeders, (2) unicellular eukaryote feeders, (3) carnivores, and (4) plant feeders. The genera that contributed more than 50 % to the differences among sites A and B are indicated in bold. Rhabditid nematodes other than *P. marina* were identified to family level.

already apparent at site A from day 10 onwards. The abundance of *Pellioiditis* increased over time at both sites to more than 60 % of total nematode abundance after 30 days. The other colonising genera are listed in Table 7.1. *Monhystera* and

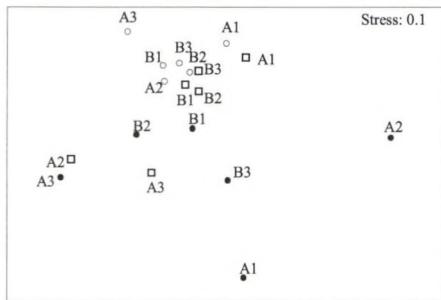
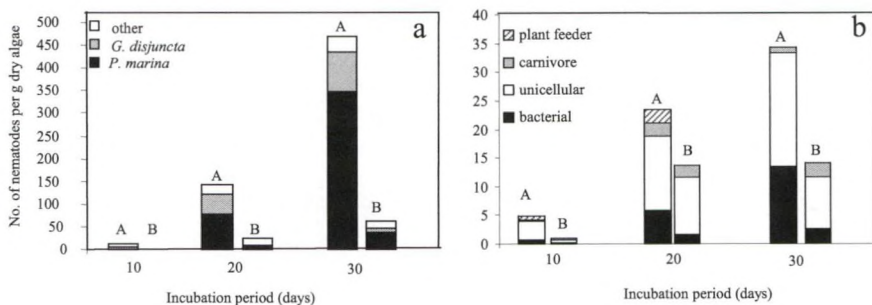

**Fig. 7.3:** Non-metric multidimensional scaling plot of the generic composition of the patches at each sampling occasion. Closed circles are replicates after 10 days, open squares after 20 days and open circles after 30 days of incubation. Sample names refer to sites (A or B) and patches (1, 2 and 3).

*Daptonema* were frequently found on the *Fucus* thalli in both sites, whereas *Syringolaimus* was only encountered in site B. Community composition between both sites was not significantly different (two-way crossed ANOSIM,  $R = 0.16$ ,  $p = 0.09$ ). In contrast, time effects were significant ( $R = 0.31$ ,  $p = 0.02$ ; Fig. 7.3).

Pairwise comparisons showed that samples after 10 days were clearly separated from those after 30 days of incubation ( $R = 0.49$ ,  $p = 0.04$ ), while samples taken after 20 days were not significantly different from those after 30 days ( $R = 0.20$ ,  $p = 0.2$ ) and after 10 days ( $R = 0.32$ ,  $p = 0.08$ ). This implies that the nematode community converged over time across sites. SIMPER analysis indicated that the genera *Pellioiditis* (21.69 %), *Geomonhystera* (14.89 %), *Monhystera* (8.94 %), *Daptonema* (8.24 %), and *Metachromadora* (5.42 %) contributed most to the observed differences between day 10 and day 30.

Pairwise comparisons showed that samples after 10 days were clearly separated from those after 30 days of incubation ( $R = 0.49$ ,  $p = 0.04$ ), while samples taken after 20 days were not significantly different from those after 30 days



**Fig. 7.2:** (a) Absolute abundances of the dominant genera at sites A and B during the experiment. (b) Absolute abundances of the feeding types according to Moens et al. (2004), with feeding type referring to the dominant type within each genus. The genera *Pellioiditis* and *Geomonhystera* were omitted from the dataset.

When all genera were assigned to the feeding type classification of Moens et al. (2004), both sites were dominated by bacterial feeders. Because this is mainly a

reflection of the high abundances of *P. marina* and *G. disjuncta*, these two species were omitted from the dataset. This resulted in a dominance of unicellular eukaryote feeders in both sites (Fig. 7.2b).

COLONISATION OF FUCUS BY *P. MARINA*

Although absolute nematode abundances were fivefold higher at site A than B,

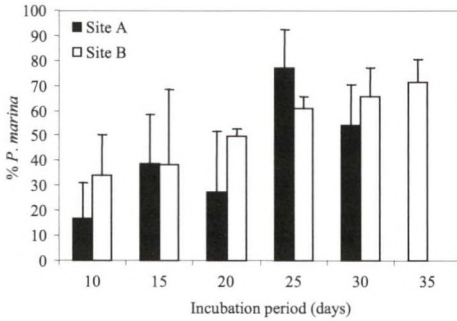

**Fig. 7.4:** *Pellioiditis marina*. Relative abundance at site A and site B during the experiment. Each column is the average of three patches and error flags are standard deviation across three patches.

the percentage of *P. marina* in both sites was comparable and ranged between 25 – 70 % (Fig. 7.4). This was confirmed by the repeated measures ANOVA, which showed no significant differences between sites ( $F_{1, 4} = 0.63$ ;  $p = 0.47$ ). The relative abundance of *P. marina* gradually increased with time ( $F_{4, 16} = 7.92$ ,  $p = 0.001$ ) and this increase followed a similar pattern in both sites (site x time effect  $F_{4,16} = 1.5$ ,  $p = 0.25$ ).

GENETIC PATTERNS AND DIVERSITY OF *P. MARINA*

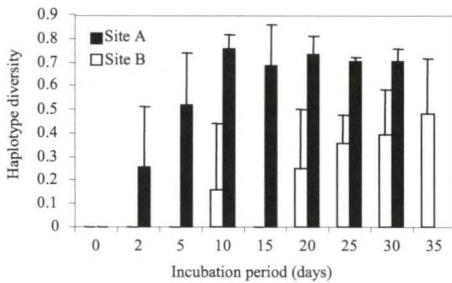

**Fig. 7.5:** *Pellioiditis marina*. Haplotype diversity (*h*) at site A and site B during the experiment. Values are averages of three patches and error flags are standard deviation across patches.

Genetic variation was assessed from 478 *P. marina* specimens from site A and 514 specimens from site B. Fig. 7.5 shows the patterns of haplotype diversity (*h*) for both sites. *h* was clearly higher in site A ( $F_{1,4} = 176.76$ ,  $p = 0.0002$ ) and increased over time in both sites ( $F_{6,24} = 5.49$ ,  $p = 0.001$ ). The pattern of this increase did not differ significantly between sites (site x time effect,  $F_{6,24} = 1.47$ ,  $p = 0.23$ ).

In total, 11 haplotypes were found, 10 of which were present in site A and eight of which were found in site B (Fig. 7.6). Divergences among these haplotypes ranged between 0.25 - 2.02 % (1 – 8 substitutions). Differences in haplotype composition and in the type and number of dominant haplotypes were noticeable between both sites and between patches in a site (Fig. 7.6). Patches in site B typically had a lower number of haplotypes than those in site A (on average 4 and 7, respectively, Fig. 7.6). The haplotype composition was clearly different between both sites, with patches of site A closely resembling those of the presumed source population (Pa) (data not shown). One new haplotype was observed (G) in comparison with our earlier studies. In addition, haplotype W was not encountered previously in Paulina, but has been observed elsewhere in the Westerschelde estuary (Derycke et al. 2006).

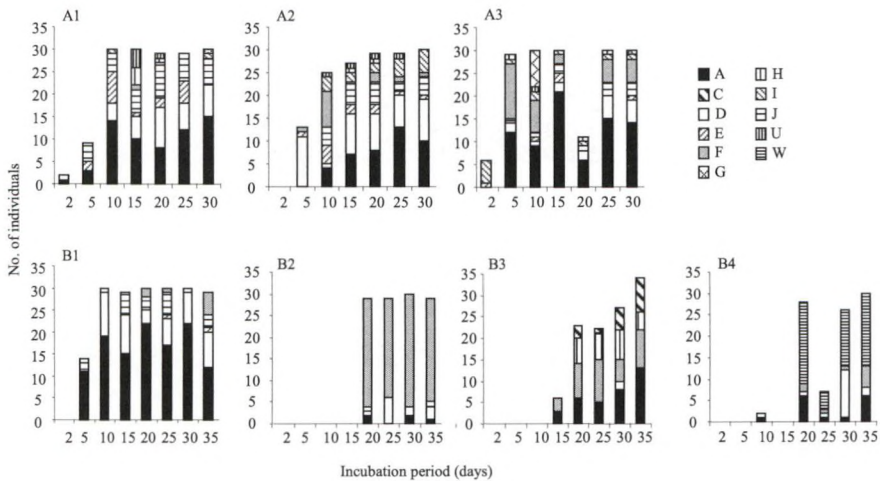

**Fig. 7.6:** *Pellioditis marina*. Haplotype composition of the developing *P. marina* populations for each patch separately. A1-A3 refer to the three patches in site A, B1-B4 refer to the four patches in site B. A-W are codes for haplotypes.

AMOVA indicated that genetic differences were detectable between both sites, and genetic differentiation was 10-fold higher among patches in site B than among patches in site A. Fstat analysis indicated that this 10-fold difference of genetic differentiation between the two sites was significant (Fstat,  $p = 0.04$ ). On the other hand, AMOVA indicated that genetic differentiation over time was small in both sites (Table 7.2). Fst values between site A and the source population were small (0.0 – 0.03), while Fst values between site B and the source population ranged between 0.02



- 0.39. However, this difference among  $F_{st}$  values of both sites was not significant ( $U = 2.0, p = 0.15$ ).

	df	F-statistics	% variation	p
<b>Site A</b>				
Among patches	2	Fct = 0.031	3.13	< 0.001
Among samplings within patches	17	Fsc = 0.056	5.42	< 0.0001
Within samplings	458	Fst = 0.085	91.45	< 0.0001
<b>Site B</b>				
Among patches	3	Fct = 0.35	34.84	< 0.0001
Among samplings within patches	17	Fsc = 0.026	1.71	< 0.0001
Within samplings	493	Fst = 0.37	63.46	< 0.0001

**Table 7.2:** *Pellioditis marina*. Results of the hierarchical AMOVA to infer genetic differentiation within sites A and B. % = % of the variation explained by;  $p$  = significance level of the  $F$ -statistics; Fct = correlation among haplotypes within patches relative to the correlation of random pairs drawn from the site (A or B); Fsc = correlation among haplotypes within time samples relative to the correlation of random pairs drawn from the patch; Fst = correlation among haplotypes within time samples relative to the correlation of random pairs drawn from the site (A or B).

COLONISATION DYNAMICS OF HAPLOTYPES

Bray-Curtis similarity coefficients increased during the first 10 (site A) and 20 days (site B) (data not shown). At days 10 (site A) and 20 (site B), similarity was very high and ranged between 79.21-84.51 in site A and between 85.03-95.27 in site B. This indicates that new haplotypes were mainly added during the first 10 days for site A and during the first 20 days for site B (Figure 7.6).

When we compared the relative abundances of the first haplotypes colonising the patches with their abundances at the end of the experiment, a significant positive correlation was observed only at site B ( $R = 0.83, p = 0.0028$ ; site A:  $R = 0.56, p = 0.19$ ). Hence, at this site, haplotypes colonising the patches at the onset of the experiment constituted an important part of the population after 35 days.

## DISCUSSION

### NEMATODE COMMUNITY STRUCTURE AND ABUNDANCE

The litter in the present study was colonized by a variety of typically benthic nematode genera, such as *Daptonema* and *Theristus*, which are not specifically associated with *Fucus* detritus, but opportunistically take advantage of the available resources (De Mesel 2004). Of the two most abundant species in our experiment, *P. marina* and *G. disjuncta*, the latter is a generalist which occurs on all sorts of litter as well as in sediment in and along the edges of the Paulina marsh where our experiment was conducted (Moens, T., unpubl.). *P. marina*, by contrast, is more restricted to seaweeds, both live and dead, and does not live in the sediment (Bouwman et al. 1984; Moens, T., unpubl.). Both species colonized the experimental *Fucus* patches during the first days of the experiment and showed a rapid population growth. This may influence the population development of the other colonising taxa and may prevent the settlement of new taxa (Jenkins & Buikema 1998, De Meester et al. 2002). This is not in contradiction with the five new taxa that were found after 30 days incubation at site B, because abundances of *P. marina* and *G. disjuncta* were much lower at site B than at site A, which left more available space for other nematodes. Several nematode species have been observed to raft (Thiel & Gutow 2005) and consequently, drifting algae typically contain nematode assemblages upon deposition on the shore. The presence of a dispersal propagule may influence subsequent colonisation by other nematodes through interspecific interactions. The presence of other species would probably have only very limited consequences for the results of our study, however, because *P. marina* is the most successful colonizer species on freshly decomposing macroalgae and its population dynamics do not seem to be affected by the presence of other microbivorous nematodes (Moens et al. 1996, dos Santos et al. in prep.).

The fivefold lower nematode abundance at site B was apparently caused by a slower colonisation of the patches, a slower population development, or a combination of both. A slower rate of colonisation may have been caused by the larger distance of site B to a source population. In addition, site B is a more variable and stressful environment, because it is slightly higher up in the littoral than site A and consequently experiences longer low-tide exposure. Visual inspection indicated,

for instance, that algae at site B were episodically subject to drying through exposure to wind, a factor known to hamper population development (Moens & Vincx 2000). The lower abundances in the single patch at site B that was colonized as rapidly as the patches at site A strengthen the assumption of suboptimal conditions for population development in most patches at site B.

#### COLONISATION OF *FUCUS* BY *P. MARINA*

In spite of the lower absolute abundances of total nematodes and of *P. marina* at site B, the relative abundances of *P. marina* were similar in both sites and increased over time at the expense of the other genera. As expected, colonisation and population development at site A occurred faster. This is probably because on the permanent algal stands in site A *P. marina* acted as a source population from which both active and passive dispersal could occur. In fact, colonisation of *P. marina* at site A was slower than expected considering its high reproductive output (up to 600 eggs female<sup>-1</sup>, Vranken & Heip 1983), its short generation time (less than 5 days under the field conditions, Moens and Vincx 2000) and its potential for active and passive dispersal. Considering the biology of *P. marina* and the very short distance between patches within a site (ca. 2 m), the significant genetic differentiation among patches within a site (see also next section) suggests that gene flow among these patches was limited and hence, that effective migration (= migration followed by successful reproduction) in *P. marina* is low.

#### GENETIC PATTERNS AND DIVERSITY OF COLONISING *P. MARINA*

As expected, we found a larger genetic differentiation between *P. marina* populations at site B than between those at site A. Several observations indicate that patches at site B acted as non-equilibrium demes (i.e. a set of populations among which little or no recolonisation occurs, Harrison & Hastings 1996). First of all, the lower haplotype diversity and lower absolute *P. marina* densities at site B early in colonisation indicate that the propagule initially colonising site B was smaller than that colonising site A. This can be explained by a combination of distance from the source population, which has a diluting effect, and the suboptimal conditions at site B, which hampered population development. Secondly, the non-equilibrium characteristics of site B are reflected in the haplotype composition of the colonising

nematodes. Haplotypes that first colonized patches at site B determined the population genetic composition after 35 days. Furthermore, three of the four patches at site B were dominated by haplotypes (C, F, and W) which are rare at Paulina and the polyhaline part of the Westerschelde (Derycke et al. 2005, 2006). Rare haplotypes that become abundant in a population are typical for founder events and genetic bottlenecks (De Meester et al. 2002, Haag et al. 2006). The lower number of haplotypes at site B compared with the source population support the occurrence of a genetic bottleneck. Thirdly, AMOVA demonstrated that there was a very high genetic differentiation between patches in site B, indicating that little gene flow among patches occurred.

Genetic differences among patches at site A were small, but nevertheless still significant, and indicated that founder events also occurred at site A. This result is striking because patches at site A lay within the source population and colonisation rates at site A were high. Interestingly, according to the Bray-Curtis analyses, changes in the haplotype composition over time were small at both sites, especially after 10 days at site A and after 20 days at site B. Several scenarios may produce such a pattern. First, individuals arriving at empty patches at each site may establish a population with no new individuals added during the remainder of the experiment. Considering that up to 10 % of endobenthic nematodes and an even larger part of nematodes on phytal substrata can be suspended during a single tidal cycle (Fegley 1987, Alkemade et al. 1994), it is very unlikely that no new individuals arrived at our patches after initial colonisation. This is especially true for site A, at which *P. marina* should be able to actively migrate from the source population to the patches. A second explanation would be that our mitochondrial marker, which is maternally inherited, was not able to detect newly arriving individuals. This is in fact partly true: the COI marker overlooks the effect of newly arriving males, and in this way can miss new haplotypes. However, this effect should be of minor importance, because the ratio males:females in *P. marina* is slightly biased in favor of females (~67 % females at the temperatures during our experiment, Moens & Vincx 2000). Thirdly, if individuals that are added during the experiment have identical haplotypes to the 'founders', we would also not detect temporal differences. This scenario is unlikely, however, as all patches were clearly different from each other. Thus new dispersal propagules, each originating from a homogeneous source population, are unlikely to have a haplotype composition similar to that of the populations already present on the

patches, especially at site B. Alternatively, individuals that are added during the experiment after initial colonisation (i.e. after 10 days at site A and 20 days at site B) may have different haplotypes than the founders, but remain in very low frequency in the patches. This pattern is characteristic for the 'persistent founder effect', in which new haplotypes do not get established due to the strong population growth of the first colonizers (Boileau et al. 1992, De Meester et al. 2002). Such priority effects are most likely the best explanation for the low variability in haplotype composition at both sites and is in agreement with the low effective migration that was observed among patches at site B, and to a lesser extent among patches at site A.

## CONCLUSION

Our field experiment shows that empty patches are rapidly colonized by nematodes. Although nematode communities were initially different between both sites, they converged over time. In contrast, genetic patterns in the dominant species, *P. marina*, remained clearly different between both sites over time. *P. marina* exhibits strong colonisation dynamics within the Westerschelde estuary, and both regional and local factors influence the population genetic structure of this species. The observed patterns of genetic variation and differentiation were in agreement with expectations from the proximity of a source population. Our results also suggest that founder effects play an important role in determining genetic differentiation in *P. marina* populations. The observed genetic differentiation among sites and among patches within sites further indicates that effective dispersal of *P. marina* is lower than previously thought and that priority effects best explained the observed patterns in the genetic structure of this species.

## ACKNOWLEDGEMENTS

We thank Annick Van Kenhove for mounting the nematodes on slides and Dirk Vangansbeke for the C:N analyses of the *Fucus* samples. T. Backeljau, L. De Meester and two anonymous referees made valuable comments on earlier drafts of the manuscript. S.D. acknowledges a grant from the Flemish Institute for the Promotion of Scientific Research (IWT). T.M. is a postdoctoral fellow with the Flemish Fund for scientific Research. Further financial support was obtained from Ghent University in BOF-projects 0110600002 and 01GZ0705 (GOA-BBSea).

118976

---

CHAPTER VIII

EFFECTS OF SUBLETHAL ABIOTIC STRESSORS ON  
POPULATION GROWTH AND GENETIC DIVERSITY OF  
*PELLIODITIS MARINA* (NEMATODA) FROM THE  
WESTERSCHELDE ESTUARY

---

Published as:

Derycke S, Hendrickx F, Backeljau T, D'Hondt S, Camphijn L, Vincx M, Moens T (2007) Effects of sublethal abiotic stressors on population growth and genetic diversity of *Pellioditis marina* (Nematoda) from the Westerschelde Estuary. **Aquat Toxicol**, DOI: 10.1016/j.aquatox.207.02.002

**ABSTRACT**

Understanding the effects of anthropogenic pollutants at the ecosystem level requires a proper understanding of the toxicological effects at the population level. Species living in estuaries resist highly fluctuating conditions, and are often exposed to sublethal concentrations of pollutants coming from industrial and domestic wastes. In the Westerschelde estuary, the most upstream sampled population of the nematode *Pellioiditis marina* is genetically less diverse than elsewhere, while it experiences lower salinities and higher Cd concentrations than more downstream populations in the estuary. In the present study, we investigate whether these environmental conditions may explain the lower genetic diversity in the most upstream location. To this end we followed the development of genetically diverse *P. marina* populations under experimental conditions during 14 days. Genetic diversity was assessed in the F1, F2 and F5 generation by screening mitochondrial cytochrome oxidase c subunit 1 variation with the single-strand conformation polymorphism method (SSCP) and nucleotide sequencing. Our results show that sublethal Cd concentrations reduce population development of *P. marina* at suboptimal salinities, and that low salinity conditions induce responses at the genetic level. Nevertheless, the genetic effects were not persistent over generations, which emphasize the need for longer multigenerational experiments.

## INTRODUCTION

The effects of anthropogenic pollution on ecosystems are important for management and conservation, and have led to the emergence of ecological risk assessment (ERA) strategies. Understanding and predicting effects of toxicants at the ecosystem level requires, however, a proper understanding of toxicological effects at the population level (Bickham et al. 2000, Forbes & Calow 2002). The effects of chemical pollutants are often difficult to predict (Belfiore & Anderson 2001, Van Straalen & Timmermans 2002). For example, selection may lead to genetic erosion or, in contrast, to an increased diversity (Van Straalen & Timmermans 2002, Gillespie & Guttman 1999). Mutations may be a risk to the population due to 'mutational load' but they may also increase the adaptive potential of the population (Van Straalen & Timmermans 2002). Toxicants may also induce demographic bottlenecks thereby reducing the effective population size (Van Straalen & Timmermans 2002). This almost always leads to a reduction in genetic diversity (De Wolf et al. 2004).

ERA strategies traditionally use acute rather than sublethal toxicity tests (but see Dahl et al. 2006). Sublethal concentrations of some metals may, however, become lethal under suboptimal environmental conditions. The toxicity of a metal further strongly depends on its free ion activity which in turn depends on salinity and complexation capacity (Blust et al. 1992). For instance, organisms living along the salinity gradient in the Westerschelde estuary (The Netherlands) may experience physiological stress, but the estuary is also heavily polluted with levels of particulate Cd 10 to 50 times higher than in unpolluted seas and oceans (Baeyens 1998). These elevated Cd levels may affect the fitness of populations and/or their genetic diversity (De Wolf et al. 2001).

The free-living bacterial-feeding nematode *Pellioiditis marina* (Bastian, 1865) typically lives on macroalgae in the littoral zone of coasts and estuaries around the world. In the Westerschelde estuary, *P. marina* is abundant from the mouth to the mesohaline area just before the nature reserve 'Land van Saeftinghe' where salinities are around 10. Its presence in the upper mesohaline and especially in the oligohaline area is rare, which has been explained by a lower scope for growth and hence reduced fitness of *P. marina* at these low salinities (Moens & Vincx 2000b). Interestingly, a population genetic survey of *P. marina* along the estuary showed a reduced mitochondrial DNA diversity in a population just downstream of the 'Land van



Saeftinghe', where at the same time the highest levels of heavy metal pollution (including Cd) are observed compared to the other areas in the Westerschelde where *P. marina* is abundant. It could thus be hypothesized that this low population genetic diversity results from demographic bottleneck effects caused by the suboptimal environmental conditions (i.e. lower salinity and higher Cd concentrations, Derycke et al. 2005, 2006). Interestingly, a similar reduction in genetic diversity in the upstream part of the Westerschelde has been observed in the gastropod *Littorina littorea* (De Wolf et al. 2004).

The aim of this study was to assess, under controlled experimental conditions, whether sublethal Cd concentrations in combination with suboptimal salinities in the mesohaline zone of the Westerschelde induce 1) a demographic bottleneck in *P. marina*, 2) a genetic bottleneck and/or 3) a shift in haplotype composition. Therefore, population development was followed every day during two weeks, and the mitochondrial DNA diversity of the cytochrome oxidase c subunit 1 (COI) gene was analysed in three generations (F1, F2 and 'F5'). We expected that salinity and Cd values observed in the mesohaline location just before 'Land van Saeftinghe' in the Westerschelde would result in a lower offspring production and/or in a reduced genetic diversity, compared to the higher salinity and lower Cd values at more downstream sites in the Westerschelde.

## MATERIAL AND METHODS

### TEST ORGANISM AND STUDY POPULATION

*Pellioiditis marina* is a free-living nematode belonging to the Rhabditidae. It has several features that are advantageous in ecotoxicological research: a very short generation time (3 days under optimal conditions, Moens & Vincx 2000a), a high fecundity (up to 600 eggs female<sup>-1</sup>, Vranken & Heip 1983), and it is easily culturable in the lab (Moens & Vincx 1998). It is an obligate sexually reproducing, oviparous to ovoviviparous species and females require the presence of males to deposit their eggs. *P. marina* lives and reproduces over a wide salinity range, and respiration and assimilation rates differ slightly at salinities between 10 and 30 (Moens & Vincx 2000b).

For this experiment, *P. marina* specimens were collected from the Paulina saltmarsh (Pa) situated in the polyhaline area of the Westerschelde estuary. The life-history characteristics and genetic diversity of this population are well known (Moens & Vincx 2000a, b, Derycke et al. 2006). In the Pa population, up to three cryptic species have been encountered in sympatry (PmI, PmII and PmIII). PmI is used in this study as it is the most abundant cryptic species and the only one that has hitherto been observed in the most polluted location in the Westerschelde (Kruispolderhaven - Kr). In Kr, genetic diversity of PmI is very low all year round, while the PmI population in Pa is one of the genetically most diverse populations in the estuary (Derycke et al. 2006). *Fucus* fragments were incubated on agar layers (0.7 % agar, bacto- and nutrient agar in a ratio of 10/1; salinity of 25, buffered at a pH of 7.5 - 8.0 with Tris-HCl in a final concentration of 5 mM). In this way, *P. marina* can efficiently be observed, identified and sorted under a dissecting microscope.

Importantly, nematode populations may be adapted to local conditions (Forster 1998, Moens & Vincx 2000a), rendering environmental history a potential confounding factor when assessing the effects of salinity and/or Cd on demographic/genetic parameters. Nevertheless, Pa is an ideal reference population to test whether abiotic stressors observed in the field influence demographic parameters and genetic diversity of PmI.

### TEST CONDITIONS

The objective of this experiment was to test whether gradients in Cd concentrations and salinity in the Westerschelde can explain the lower genetic diversity of the field population of *P. marina* (PmI) in the mesohaline area. The dose range of Cd was intended to comprise a high but sublethal dose ( $x$ ) that is likely to influence population development, and two lower doses ( $x/10$  and  $x/100$ ). The Cd concentration in our reference site (Pa) is ca.  $1 \text{ mg l}^{-1}$  (Baeyens 1998, Rijkswaterstaat, [www.waterbase.nl](http://www.waterbase.nl)). The Cd concentration in the upstream location (Kr), where a reduced mitochondrial DNA diversity of *P. marina* was observed (Derycke et al. 2005), is  $3 \text{ mg l}^{-1}$ . A preliminary experiment was performed with concentrations of 0.1, 1, 3 and  $10 \text{ mg l}^{-1}$  Cd. At the highest Cd concentration ( $10 \text{ mg l}^{-1}$ ), almost all adults died after a three days inoculation and very few offspring was observed. Consequently, we did not use this Cd concentration in the final experiment.

In the Westerschelde estuary, *P. marina* occurs at salinities between 10 and 35 (Moens T. pers. comm.). Salinity in the reference site (Pa) averages 25, in Kr 12, and these concentrations were used as test conditions. We also included treatments with a salinity of 35. Each of the three different Cd concentrations was prepared at each of the three salinities. Hence, nine different experimental treatments (3 Cd concentrations  $\times$  3 salinities) were obtained and were numbered according to increasing salinity and increasing Cd concentration (see Fig. 8.2). The treatment with a salinity of 25 and a Cd concentration of  $1 \text{ mg l}^{-1}$  mimicked the field conditions in Pa and served as the reference treatment, whereas the treatment with a salinity of 12 and a Cd concentration of  $3 \text{ mg l}^{-1}$  represented the field conditions in Kr.

### EXPERIMENTAL DESIGN

The effects of Cd and salinity were tested by adding  $\text{CdCl}_2 \cdot 2.5\text{H}_2\text{O}$  (Merck) in final concentrations of 0.1, 1 and  $3 \text{ mg l}^{-1}$  to sterile agar layers (1 % bacto agar, 0.05 % cholesterol, pH 7.5 - 8) with respective salinities of 12, 25 and 35. We used square petridishes of 12 x 12 cm and poured 60 ml of agar in the dishes. When the agar was solid, we pushed a sterile ring in the middle of the dish and inoculated the nematodes in the centre of this ring. As such, the area available for colonisation was restrained (Fig 8.1). After one week, the ring was removed with a sterile forceps,

allowing the nematodes to invade completely fresh substrate (Moens & Vincx 1998). This procedure allowed us to extend the duration of the experiment beyond three generations – which is normally the timing where in closed microcosms *P. marina* adult mortality rapidly increases and juveniles start to show delayed maturation – without inducing any kind of reduction in the population size or genetic diversity of the experimental population.

Food was standardized across treatments by adding UV radiated *E. coli* cells ( $2 \times 10^{10}$  cells ml<sup>-1</sup>). These bacterial cells are unable to reproduce due to DNA damage. *E. coli* cells have only very low levels of an intracellular Cd binding component (Khazaeli & Mitra 1981), hence the presence of bacteria was unlikely to affect available Cd concentrations in our microcosms. Bacteria were added at the start of the experiment and again after one, three and five weeks.

Approximately 1000 adult nematodes were handpicked from 236 agar plates upon which algae from the reference site (Pa) had been inoculated. They were washed in a mixture of sterile artificial seawater and antibiotics (streptomycin, 0.5 mg ml<sup>-1</sup>; penicilline, 1000 U ml<sup>-1</sup>) to eliminate most of the bacteria that were cotransferred with the nematodes. Nematodes were then transferred to the microcosms in four consecutive series of 10, 10, 10 and 5 individuals per microcosm, resulting in a total of 35 nematodes per dish ('parent generation'). The transfer in four series avoided sorting bias, because one unconsciously tends to sort larger and more motile organisms first. Male/female ratio in the inoculum was ca. 10/25.

Nematodes were counted daily during the first two weeks of the experiment, which was long enough to produce 2 to 3 generations. The parent generation (P) was allowed to produce offspring during the first two days of the experiment and was subsequently removed from the dishes. During this period adult mortality was monitored. The remaining nematodes were F1 offspring. Six days after the start of the experiment, we randomly handpicked 50 adult F1 nematodes from each dish. After eight days, we randomly handpicked 50 juveniles from each microcosm (F2 generation). Finally, after one month, we again randomly handpicked 50 nematodes (Fig 8.1). At this point, generations were no longer synchronised, and the nematode population consisted of a mixture of different generations (F2 – F6), because it was impossible to remove all F1 and F2. Based on the average generation time of *P. marina* in our experiment, we refer to this as the 'F5 generation'. All sorted nematodes were preserved on acetone until processing for molecular analyses.

**Figure 8.1:** Diagram of the experimental design. In total, 27 squared agardishes were prepared (3 salinities \* 3 Cd concentration \* 3 replica's).

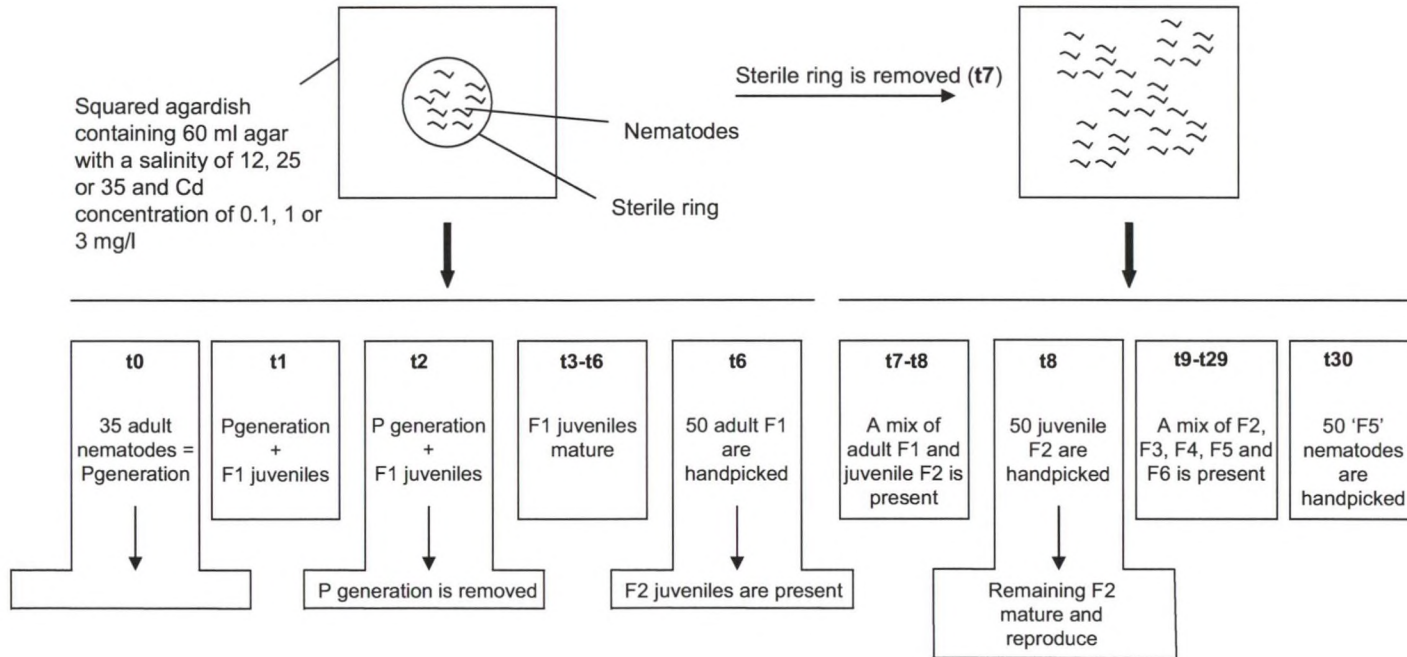

*MOLECULAR ANALYSIS OF POPULATION GENETIC DIVERSITY*

We randomly picked 2 x 25 nematodes from the ca. 1000 nematodes isolated before the start of the experiment to evaluate the haplotype diversity in the parental generation. From the 50 specimens that were handpicked from each generation and each dish, 30 were screened for variation at the mitochondrial cytochrome oxidase c subunit 1 gene (COI) using the Single Strand Conformation Polymorphism (SSCP) method (Orita et al. 1989). A detailed description of the DNA-extraction, PCR-, SSCP- and sequencing protocols can be found in Derycke et al. (2005). In short, DNA was extracted from single nematodes and the COI was amplified with the primers JB3 and JB5. Each PCR product was subsequently loaded on an acrylamide gel to assess variation in the COI gene with the SSCP method. Each sample with a different banding profile was sequenced. We found 8 new COI sequences compared to Derycke et al. (2005, 2006) and submitted them to GenBank (AM412585-AM412592). The remaining 17 haplotypes are listed under accession numbers AJ867447-AJ867451, AJ867455 - AJ867457, AJ867465, AJ867477, AJ867462, AJ867463, AJ867468, AJ867471, AJ867474, AM076731 and AM076732.

*DATA ANALYSIS*Population development

Differences in nematode abundances, in parental mortality and in the percentage females over time between treatments were analysed with the GLIMMIX (Generalized Linear Mixed Models) procedure in SAS v.9.1 (Sas Institute Inc. 2004). GLIMMIX performs a logistic regression to model the response of non-Gaussian distributed data in relation to one or more environmental predictors. The random statement was used to correct for the random effect of replicates and the dependency of the repeated observations for nematode abundances and percentage females.

Subsequently, we calculated two parameters: 1) the number of F1 offspring female<sup>-1</sup> based on the juvenile counts after three days, 2) the population development based on adult counts after two weeks.

Differences in F1 offspring per female and population development between treatments were analysed with a two-way factorial ANOVA in Statistica 6.0 (Statsoft 2001). Counts were log transformed to fulfill the assumptions for parametric tests.

When significant results were obtained, a Tukey HSD post-hoc test was used for pairwise comparisons (Sokal & Rohlf 1997).

### Genetic diversity

Haplotype diversity ( $h$ , Nei 1987) of PmI was determined in the two replicates sorted at the start of the experiment to assess diversity in the parental generation, and subsequently in the F1, F2 and 'F5' generation in three replicates for each treatment. We also used the haplotype diversity from the field population of PmI in Paulina from four consecutive seasons (Derycke et al. 2006) as a measure of its natural 'field diversity'. While other lineages than PmI were extremely rare in the F1 and F2 generation of all our experimental treatments, PmII was fairly abundant in the F5 generation of some treatments and was omitted from the analysis of the population genetic diversity of PmI. The effects of this sample bias on the number of PmI haplotypes were investigated with the rarefaction method. Haplotype frequencies of the F1 and F2 generation from each treatment were used to construct a haplotype pool from which subsamples ( $n$  between 1 and 30) were taken using the rarefaction calculator available at <http://www2.biology.ualberta.ca/jbrzusto/rarefact.php>. We plotted the expected number of haplotypes against sample sizes for all treatments. Sample sizes above 10 still yielded reliable estimates of the number of haplotypes (data not shown). Six replicates in which the number of PmI individuals was lower than 10, were omitted from the dataset (1, 2, 2 and 1 replicate(s) from treatments 4, 7, 8 and 9, respectively).

Differences in  $h$  across generations and between treatments were assessed with the General Linear Mixed Models (GLMM) procedure using SAS v.9.1 (SAS Institute Inc. 2004). The fixed effects of salinity, Cd and generation, along with their two-way and three-way interaction effect(s) were included in the model. The dependence of generations within replica's and the random effects of replica's were caught by including the 'repeated' statement in the GLMM module. The variance components best fitted the variance-covariance structure of the data. Significant test results were followed by the Tukey HSD post hoc test. A backward stepwise deletion of non-significant effects was applied to determine the final model.

Differences in haplotype composition between treatments were evaluated in three ways. First, Analysis of similarity (ANOSIM) was performed with the software package Primer 5.2.9 (Clarke 1993, Clarke & Warwick 1994) to infer whether

haplotype abundances were influenced by salinity or Cd. The Bray-Curtis similarity coefficient was calculated with double-root transformed and standardized data to include the importance of rare haplotypes. We performed a two-way crossed ANOSIM (factors salinity and Cd) for the complete dataset (i.e. 9 treatments and three generations).

Second, to investigate whether shifts in haplotype composition occurred between the F1 and 'F5' generation in test treatments compared to the control treatment, a one-way ANOVA was performed on Bray-Curtis similarities, which were calculated between the F1 and 'F5' generation of each replicate. We also plotted *k*-dominance curves of the Pml haplotypes to investigate whether treatments were dominated by specific haplotypes and whether shifts in dominance could be observed across generations.

Third, we investigated whether the haplotype composition of Pa shifted towards a less diverse composition under stressful conditions. Haplotypes (A, C, D, F and H) that occur in Kr were pooled in a class 'Kr' (Derycke et al. 2006), while the remaining haplotypes were pooled in a class 'Pa'. In addition, we also investigated whether the frequency of the two most abundant haplotypes (A and D) changed under our experimental conditions. Differences in the proportion of the 'Pa' and 'AD' classes across different salinities, Cd concentrations and generations were investigated with the GLIMMIX (Generalized Linear Mixed Models) procedure in SAS v.9.1. The binomial distribution of the proportion of the 'Pa' and 'AD' class followed a compound symmetry variance-covariance structure.

## RESULTS

### *POPULATION DEVELOPMENT*

Mortality in the parental generation of the nine treatments was consistently low and average values ranged between 0 and 5.2 % relative to the total number of individuals after one day, and between 0 and 6.8 % after two days. No significant differences between treatments were observed (time x salinity:  $p = 0.58$ ; time x Cd:  $p = 0.20$ ).



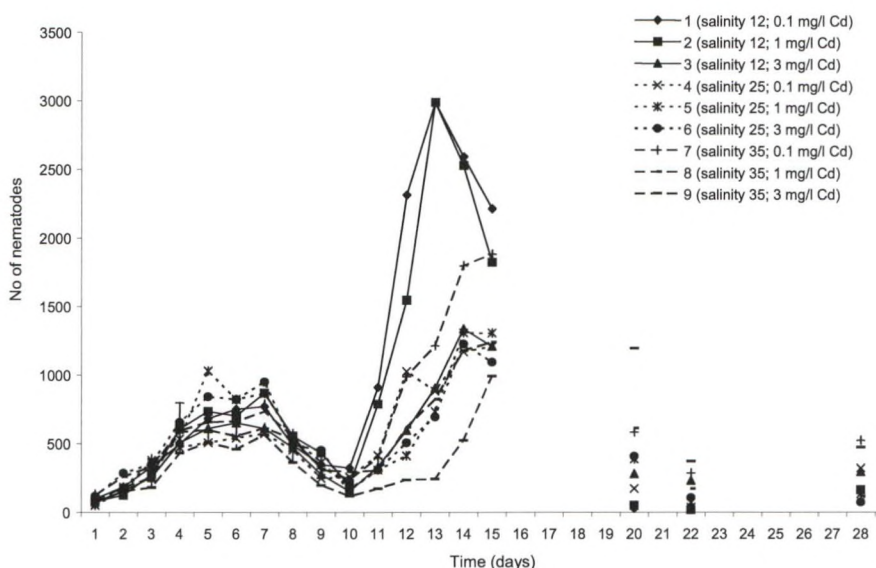

**Figure 8.2:** *Pellioditis marina*. Nematode abundances during the course of the experiment in the 9 treatments. Nematodes were counted daily during the first 14 days. Each point is the average from three replicates. Standard deviations are omitted for clarity.

During the first 10 days of the experiment, nematode abundances showed a similar pattern in all treatments (Fig. 8.2): they reached a first peak around day 7, and subsequently decreased around day 10. From then onwards, clear differences in population development were observed between treatments 1, 2, 7 and 9 (Fig 8.2). In treatment 9, the increase in abundances from 10 days onwards was slower, and peak densities were lower than in the other treatments. In contrast, the number of nematodes after 14 days was twice as high in treatments 1 and 2 and 1.5 times as high in treatment 7 as in all other treatments. Nematode abundances were significantly higher at the lowest salinity and at the lowest Cd concentration (time  $\times$  salinity,  $p < 0.0001$ ; time  $\times$  Cd,  $p < 0.0001$ ).

The percentage of females was lower in the F1 generation than in the parental generation in all treatments, but increased thereafter (data not shown). This pattern was influenced by salinity (time  $\times$  salinity:  $p = 0.004$ ) and by Cd (time  $\times$  Cd:  $p = 0.004$ ). The interaction effect between cadmium and salinity over time was also significant (time  $\times$  salinity  $\times$  Cd,  $p = 0.01$ ).

The number of F1 juveniles produced per female after 72 h differed significantly among treatments (Fig 8.3a). Two-way ANOVA showed significant salinity and Cd effects ( $p = 0.006$  and  $p = 0.001$ , respectively): the highest number of

F1 juveniles was produced at the reference salinity of 25 (treatments 4, 5 and 6). Treatments with the highest Cd concentration (treatments 3, 6 and 9) typically had lower numbers of F1 juveniles than at the lower Cd concentrations at the same salinity; this effect was most pronounced at the highest salinity (Fig 8.3a). The interaction effect was nearly significant (salinity x Cd,  $p = 0.052$ ).

Total population development as a function of salinity did not show the same pattern as the F1 production per female (Fig 8.3b). The highest population development was at a salinity of 12 (treatments 1, 2 and 3), while differences between treatments with a salinity of 25 (treatments 4, 5 and 6) and 35 (treatments 7, 8 and 9) were less pronounced. Nevertheless, an overall significant salinity effect was observed ( $p = 0.003$ ). With respect to Cd, total population development did follow the pattern of the F1 production, being lowest in treatments with the highest Cd concentration, except at a salinity of 25. For both other salinities, the differences among Cd concentrations were pronounced and resulted in a highly significant Cd effect ( $p = 0.003$ ). No significant interaction effect was detected (salinity x Cd,  $p = 0.076$ ).

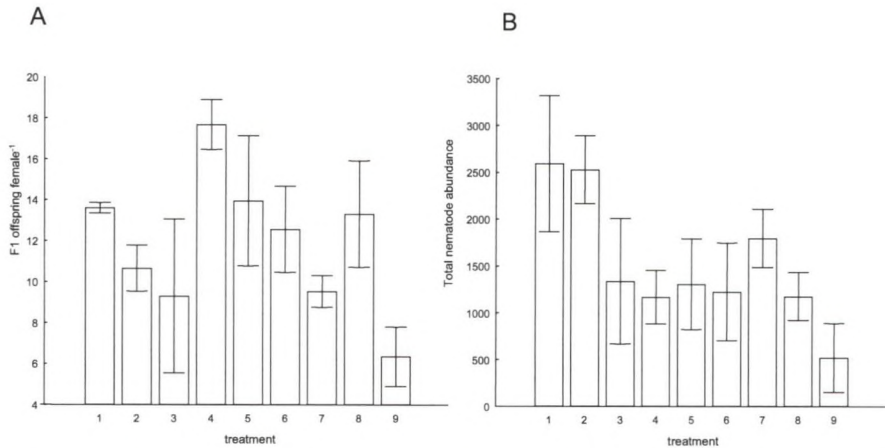
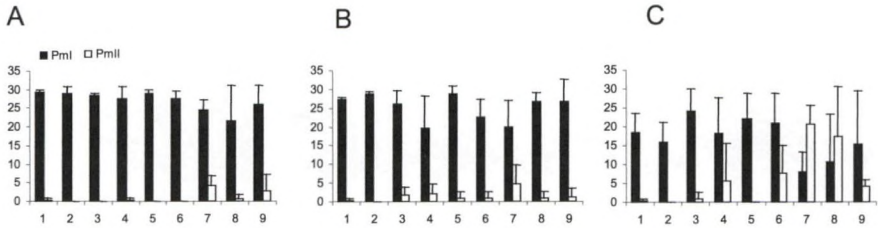

**Figure 8.3:** *Pellioiditis marina* A. Number of F1 offspring per female in each treatment; B. Nematode abundance after 14 days in each treatment. Each column represents the average of three replicates. Error bars are standard deviations from the mean. Codes for treatments are as in Fig 8.2.

#### GENETIC VARIATION

In total, 2105 nematodes were screened for genetic variation in the COI gene, 89 % of which were PmI and 11 % PmII. The latter was present in considerable

quantities in the ‘F5’ generation of treatments 7 and 8 (Fig 8.4). The PmII individuals were removed from the dataset (see material and methods section).



**Figure 8.4:** *Pellioiditis marina*. Abundances of lineages PmI and PmII in the F1 (A), F2 (B) and ‘F5’ (C) generation. Error bars are standard deviations from the mean of three replicates. Codes for treatments are as in Fig. 8.2

We found a total of 14 different PmI haplotypes, of which A and D were the most abundant (28.0 % and 28.3 % of all PmI individuals, respectively). Five haplotypes (E, F, H, I and J) were frequent (7.4 %, 7.9 %, 4.4 %, 8.8 % and 6.5 %, respectively), while the remaining seven haplotypes were rare (< 3 %, haplotypes C, D1, F1, P, U, L1 and C1). Average haplotype diversity of PmI ranged between 0.64 and 0.84 in the F1 generation of our treatments and did not differ significantly from that at the start of the experiment (0.80-0.82) or field population (0.68-0.84) ( $p = 0.051$ ) (Fig 8.5A).

Salinity had a significant effect on  $h$  across generations (salinity x generation,  $p = 0.0035$ , Table 1): a lower  $h$  was observed in the F2 generation at a salinity of 12 compared to higher salinities (Fig 8.5B). No significant effects of Cd on  $h$  were found (Fig 8.5C, Table 8.1).

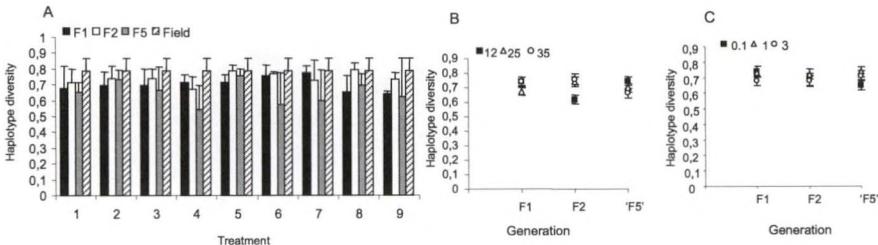
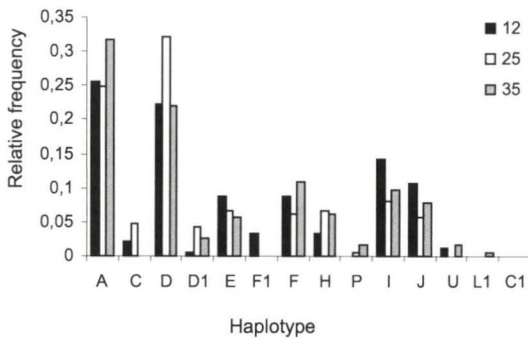

**Figure 8.5:** *Pellioiditis marina*. A. Haplotype diversity in the F1, F2 and F5 generation in each treatment. Each column represents the average of three replicates. Error bars are standard deviations from the mean. The average haplotype diversity of the field population across four consecutive seasons (Derycke et al. 2006) was added for comparison. Codes for treatments are as in Fig 8.2. B. Mean haplotype diversity in the F1, F2 and F5 generation at salinities of 12, 25 and 35. C. Mean haplotype diversity in the F1, F2 and F5 generation at Cd concentrations of 0.1, 1 and 3 mg/l. Error bars were calculated using the least squares method.

Effect	GLMM			GLIMMIX					
	dF	F	p	Pa class			AD class		
				dF	F	p	dF	F	p
Generation	2	0.33	0.71	2	1.43	0.25	2	1.04	0.36
Salinity	2	0.36	0.69	2	0.11	0.90	2	0.71	0.50
Cadmium	2	1.76	0.18	2	1.76	0.20	2	1.09	0.35
Salinity x cadmium	4	1.73	0.16	4	0.56	0.70	4	0.77	0.55
Generation x salinity	4	4.98	0.002	4	1.92	0.13	4	2.48	0.06
Generation x cadmium	4	1.14	0.35	4	1.30	0.29	4	1.77	0.15
Generation x salinity x cadmium	8	1.2	0.32	8	1.88	0.09	8	1.41	0.23

**Table 8.1:** Statistical results of the GLMM and GLIMMIX procedures on the genetic data. dF = degrees of freedom, F = F-statistic, p = significance level. Pa class refers to haplotypes that have hitherto not been observed in Kr, AD class refers to the pooled absolute frequencies of the most abundant haplotypes A and D

Haplotype composition of PmI was only weakly affected by salinity and Cd: two-way crossed ANOSIM illustrated significant differences in haplotype composition between salinity groups ( $p = 0.001$ ) and Cd groups ( $p = 0.001$ ), but the R values accompanying both factors were very small ( $R = 0.19$  and  $R = 0.16$ ,



**Figure 8.6:** *Pellioiditis marina*. Relative frequencies of the 14 haplotypes in the F2 generation at a salinity of 12, 25 and 35. Columns are the sum of frequencies across replicates within each salinity.

respectively), indicating that they contributed only little to the observed differences. Nevertheless, ANOSIM detected a borderline significant salinity effect ( $R = 0.35$ ,  $p = 0.043$ ) when only the haplotype frequencies of the F2 generation were considered. Plotting haplotype frequencies against salinity showed that haplotype A prevailed at a salinity of 35 and

haplotype D at a salinity of 25 (Fig 8.6). Both haplotypes had similar abundances at a salinity of 12, where haplotypes E, I and J also became more abundant (Fig 8.6).

The position of the k-dominance curves somewhat changes across generations (Fig 8.7). The F1 generation of PmI was dominated for at least 60 % by two haplotypes (A and D) in all treatments, except treatment 7 which had four highly abundant haplotypes (A, D, F and I, Fig 8.7A). In the F2 generation, the dominance of the most abundant F1 haplotype decreased in most treatments, but the number of haplotypes was similar as in the F1 generation. Consequently, less abundant haplotypes became more abundant at the expense of the most abundant haplotypes

(see also Fig 8.6). In the treatments with a salinity of 12, the decrease of the dominant haplotypes was most pronounced (compare the position of treatments 1, 2 and 3 to the dashed line in Fig 8.7A with those in Fig 8.7B). In the 'F5' generation, differences in dominance between treatments were more pronounced: at salinities of 12 and 35, dominance increased with increasing Cd concentration (compare the position of treatment 9 with those of treatments 7 and 8, and the position of treatment 3 with those of treatments 1 and 2, Fig 8.7C).

These patterns were, however, not significant: no significant changes were detected in the proportion of the 'Pa' and 'AD' classes as a function of salinity or Cd concentrations (GLIMMIX procedure, Table 8.1). In addition, similarities calculated between haplotype composition of the F1 and the 'F5' generation in each replicate did not significantly differ between treatments ( $p = 0.27$ ).

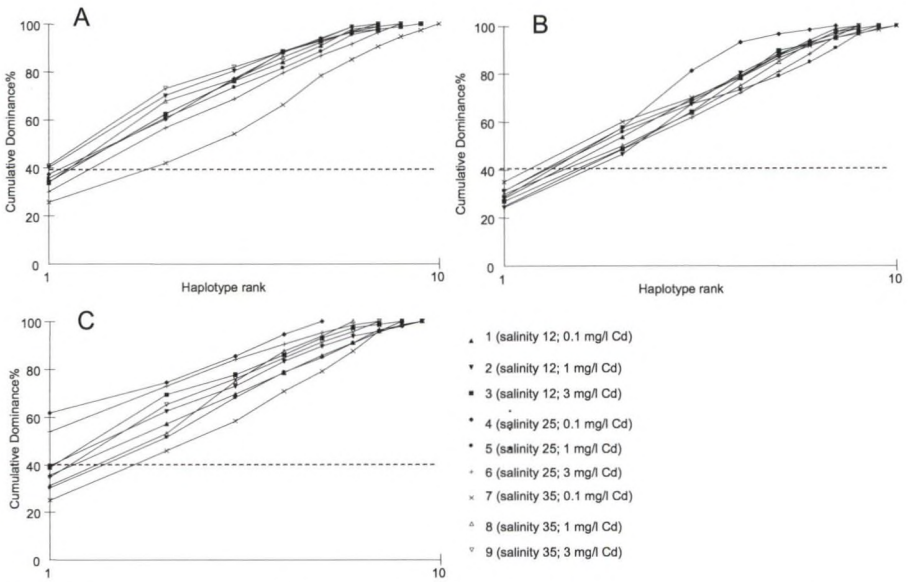

**Figure 8.7:** *Pellioditis marina*. Cumulative k-dominance curves of haplotypes in the F1 (A), F2 (B) and 'F5' (C) generation. Haplotypes are ranked in order of importance along the X-axis. Their percentage contribution to the abundance are plotted along the Y-axis.

## DISCUSSION

### POPULATION DEVELOPMENT

As a taxon, free-living marine nematodes are highly resistant to metal pollution (Heip et al. 1984). Nevertheless, at lower taxon levels, nematodes are sensitive to pollution which leads to a decrease in species diversity (reviewed in Heip et al. 1985). While toxicity tests on *P. marina* yielded LC50 and MEC (Minimal Effects Concentration, i.e. the concentration at which significant differences in the test criterion appear compared to blanks) values for juvenile mortality and development time that are 25 and 16 times higher, respectively, than the highest Cd concentration in our experiment (Vranken et al. 1985), our own preliminary experiment showed a substantial increase in adult mortality as well as a decrease in motility of *P. marina* at a Cd concentration of 10 mg l<sup>-1</sup>. In addition, fecundity and growth of *Caenorhabditis elegans*, a close relative of *P. marina*, significantly decreased at Cd concentrations similar to those in our experiment (Popham & Webster 1979). The toxicity of Cd depends on its free ion activity which increases with decreasing salinity (Blust et al. 1992). Cd activity and uptake in many marine invertebrates are typically higher at brackish than at marine salinities (Blust et al. 1992, De Wolf et al. 2002). For *P. marina* from Pa, food assimilation is relatively higher at lower salinities (Moens & Vincx 2000b). Based on the higher toxicity of Cd and the higher food assimilation rates of *P. marina* at lower salinities, the strongest Cd effect on offspring production in our experiment was expected at a salinity of 12. This is in agreement with our results on F1 offspring after 72 h: at the lowest salinity, F1 offspring was lower at increasing Cd concentrations, while this pattern was not consistent at a salinity of 35.

The effects of Cd are generally magnified with longer exposure time (Popham & Webster 1979, Vranken et al. 1985), but this was not observed in our experiment: the difference in population development between Cd concentrations after 14 days was not larger than after three days. In addition, the decrease in population development with increasing Cd concentrations was not higher at a salinity of 12 than at a salinity of 35. Fecundity of *P. marina* from Pa is also influenced by salinity and decreases at salinities above 30 (Moens & Vincx 2000a). Therefore, at a salinity of 35, the reduction in population development is most likely the result of a salinity effect rather than of Cd. Salinity and Cd may thus have contrasting effects on

*P. marina* offspring production, which is further supported by the significant interaction effects.

In addition, F1 offspring female<sup>-1</sup> after 72 h and population development were not influenced by Cd at the reference salinity of 25, which may be explained by energy allocation processes. There is evidence that *P. marina* populations along the estuarine gradient in the Westerschelde show local adaptation with respect to salinity (Moens, unpublished data), and our *P. marina* population may have been adapted to salinity conditions typical for Pa (ca 25). Consequently, nematodes at 'deviant' salinities do not only have to spend energy in detoxification, but also in adapting to those deviant salinities and may therefore have less energy for reproduction. The similar amount of nematodes after 14 days at the reference salinity regardless of the Cd concentration supports this view.

The sex ratio was influenced by salinity, corroborating previous results on the Pa population (Moens & Vincx 2000a). A female biased sex ratio has also been observed in field populations of *P. marina* (Tietjen et al. 1970, Vranken et al. 1985). In addition, Cd as well as the interaction effect of Cd and salinity significantly influenced the sex ratio, which may be indicative for a stress response of the populations. In conclusion, the population development data suggest that salinity had a larger effect on *P. marina* from Pa than Cd.

### GENETIC VARIATION

Only six different haplotypes of PmI have been reported in a year-round survey in Kr (Derycke et al. 2006), five of which were present in our experiment, including the two most abundant ones (A and D). This resulted in low diversity estimates year-round (Derycke et al. 2006). It was hypothesized that this comparatively low genetic diversity is caused by suboptimal conditions in Kr, which may hamper population development thereby enhancing effects of genetic drift. Based on the field observations, we therefore expected 1) a lower haplotype diversity, 2) a decrease in abundance of haplotypes not found in Kr and 3) an increase of the two dominant haplotypes of Kr, in treatments with a salinity of 12 and with the highest Cd concentration.

Despite clear effects of Cd at suboptimal salinities on the population development of *P. marina*, haplotype abundances and diversity were unaffected by

Cd. However, a significant reduction in haplotype diversity was observed in the F2 generation in the lowest salinity treatments. This decrease in  $h$  was the result of a change in abundances of the dominant haplotypes A and D (Fig 8.6). In the 'F5' generation, haplotype abundances at a salinity of 12 were again similar to those in the other treatments, which renders a selective advantage for specific haplotypes unlikely.

Because the effects of genetic drift are unpredictable, we investigated whether haplotype composition in each replicate changed from the F1 to the 'F5' generation by comparing similarities between treatments. After all, diversity may equally increase, or abundances of rare haplotypes may increase over time. In spite of reductions in population development in some treatments, we found no significant differences in the similarities between treatments; consequently, we were not able to detect effects of genetic drift.

The inability to detect significant (i.e. at the  $p = 0.05$  level, but note that some of the significance levels are extremely close to 0.05) genetic changes despite a reduced offspring production may be due to 1) the lack of a reduction in the effective population size, 2) the selective neutrality of our mtDNA marker, 3) the limited duration of our experiment, and/or 4) the use of Cd concentrations that were too low to induce a genetic response.

It has been shown that mitochondrial DNA is sensitive to the genetics of population bottlenecks and is an effective genetic system for monitoring population declines (Bickham et al. 2000). The effective population size ( $N_e$ ) of the mitochondrial genes at the start of our experiment was at most 20, i.e. the number of females that we initially inoculated on the agar plates. At least 100 viable nematodes were counted in all subsequent generations in all treatments, 60 % of which were females; hence,  $N_e$  was probably unaffected by our experimental conditions. Indirect reductions in mitochondrial DNA diversity may be caused by contaminants through stochastic processes such as genetic drift (Murdoch & Hebert 1994). Moreover, mitochondrial DNA variation influences organismal fitness (reviewed in Ballard & Rand 2005). A reduced mitochondrial diversity under conditions of chemical pollution has been observed in meiobenthic copepods (Street & Montagna 1996, Street et al. 1998) and in gastropods (Kim et al. 2003). We found no evidence that Cd and salinity were selectively important for PmI from Pa, because the observed decrease in  $h$  was not consistent across generations.



The likelihood of toxic substances to alter the genetic composition of populations increases when exposure lasts several generations. Although up to five generations have been included in our experiment, this may not have been sufficient to detect a significant response of sublethal concentrations at the genetic level. In estuarine copepods exposed to polycyclic aromatic carbons and pentabromo-substituted diphenyl ether, substantial genetic differences were observed already in the first generations of offspring (Street et al. 1998, Gardeström et al. 2006). Harpacticoid copepods are, however, more sensitive to pollutants than nematodes (Hicks & Coull 1983), and both cited studies used other pollutants than Cd and at rather drastic concentrations. The Cd concentrations used in this study were intended to reflect actual field concentrations. Metal resistance in estuarine nematodes may be related to environmental history (Millward & Grant 1995). Although we did not find any effects at the genetic level, we cannot exclude that a chronic, long-term exposure to moderate Cd concentrations may nevertheless result in reduced mitochondrial diversity. In this context, it is also important to note that we cannot exclude potential genetic erosion effects at the nuclear DNA level. Highly variable nuclear DNA markers, like microsatellites, may generally be more powerful in elucidating genetic erosion effects, but are hitherto not available for *P. marina*. Nevertheless, for the present study, we started from a clear observation of a reduced mitochondrial DNA diversity in a field situation. We hypothesized that bottlenecks would be the driving force for this lower COI diversity at Kr, the most upstream site sampled in the Westerschelde Estuary. Mitochondrial DNA is likely useful to identify reductions in female effective population size through genetic bottlenecks, and our experiment, with the use of COI and the screening of genetic variation in more than 2000 specimens, was designed to test precisely this hypothesis.

Finally, our data also support the contention that cryptic species may influence the genetic results when the effects of toxicant exposure are investigated (Rocha-Olivares et al. 2004). Ignoring the presence of the PmII species would have resulted in higher diversity estimates in most treatments (data not shown). Although our experiment was not designed to investigate the differential response of cryptic species, the increase in abundance of PmII at a salinity of 35 and at low Cd concentrations (Fig 8.4), and the absence of PmII at low salinities in the field, may suggest differential survival of both species.

## CONCLUSION

Our results show that Cd at field concentrations may induce a reduction in population development of PmI under suboptimal salinities. This is striking because our values were 25 times lower than the LC 50 values for *P. marina* and illustrates that even low Cd concentrations may induce demographic effects<sup>24</sup>.

Effects at the genetic level were, however, more attributable to salinity rather than to Cd, and suggest that salinity may be responsible for the low mitochondrial diversity of PmI at the upstream boundary of its distribution range in the Westerschelde. Nevertheless, our results were not persistent and experiments over more than 5 generations may be required to detect significant effects of pollutants like Cd on population genetic composition in *P. marina*, especially so when genetic drift may be at play. Future studies investigating the effects of sublethal concentrations should therefore concentrate on long-term experiments. They should also address the presence of cryptic species which may influence the results of experimental genetic data. Finally, our study demonstrates the need for monitoring several endpoints for management and risk assessment strategies in highly variable environments, like estuaries.

## ACKNOWLEDGEMENTS

We thank B. Braeckman, H. De Wolf and K. Houthoofd for valuable recommendations prior to the experiment, A. Vierstraete for DNA sequencing and two anonymous reviewers for constructive comments on an earlier manuscript draft. S.D. acknowledges a grant from the Flemish Institute for the Promotion of Scientific Research (IWT). T.M. is a postdoctoral fellow with the Flemish Fund for Scientific Research. Further financial support was obtained from Ghent University in BOF-projects 0110600002 and 01GZ0705 (GOA-BBSea).

---

<sup>24</sup> However, a reduction of growth and feeding rate at sublethal concentrations of toxicants is well documented for aquatic vertebrates (e.g. Arunachalam et al. 1980, Buckley et al. 1982, Ali et al. 2003, Rowe 2003).

118978

---

CHAPTER IX

PHYLOGEOGRAPHY OF THE *RHABDITIS* (*PELLIODITIS*)

*MARINA* SPECIES COMPLEX: EVIDENCE FOR

COSMOPOLITANISM, RESTRICTED GENE FLOW, RECENT

RANGE EXPANSIONS AND ACCELERATED EVOLUTION

---

In preparation:

Derycke S, Remerie T, Vierstraete A, Vanfleteren J, Vincx M, Moens T. Phylogeography of the *Rhabditis* (*Pellioditis*) *marina* species complex: evidence for cosmopolitanism, restricted gene flow, recent range expansions and accelerated evolution (in prep).

**ABSTRACT**

The nematode *Rhabditis (Pellioiditis) marina* has a worldwide distribution despite presumably low dispersal abilities. Recent studies on a local scale have illustrated that *R. (P.) marina* actually consists of several cryptic species which questions its true cosmopolitan distribution. We performed a phylogeographic study to identify micro- and macro-evolutionary processes shaping population structuring and speciation in the *R. (P.) marina* species complex. The mitochondrial COI gene was screened with the Single Strand Conformation Polymorphism method (SSCP) in 1292 specimens collected from decomposing macroalgae along the coasts of Western Europe, NE America, Mexico, South Africa and Australia. We found evidence for eleven cryptic species within *R. (P.) marina* that were sympatrically distributed. A strong genetic structuring was observed in all species and a genetic break was observed around the British Isles. A historical signature was present in species PmII showing evidence for two postglacial, northwards orientated expansions and for restricted gene flow with occasional long-distance dispersal. Our data also pointed to a contact zone in the Southern Bight of the North Sea. We found evidence for a true cosmopolitan distribution of nematode species due to occasional long-distance dispersal. In addition, an accelerated COI mutation rate was suggested for *R. (P.) marina*, which was about ten times higher than the generally applied molecular clock of 2 %. We further hypothesize that the cryptic radiation in *R. (P.) marina* is largely the result of allopatric speciation, and that the contemporary sympatric distribution results from occasional long-distance dispersal.

## INTRODUCTION

The absence of obvious geographical barriers and the often large dispersal capacity of organisms in the marine environment have become a paradigm (e.g. Avise 1992, Dawson et al. 2001). Nevertheless, significant structuring of marine populations may be present (Barber et al. 2000, Rocha-Olivares et al. 2001, Perrin et al. 2004), even in species with pelagic larval stages (Taylor & Hellberg 2003). Explanations for marine speciation have concomitantly shifted from a focus on broad-scale allopatric speciation to mechanisms that may be situated at much finer geographical scales than anticipated (Taylor & Hellberg 2005). Biological characteristics (e.g. limited dispersal abilities, different habitat preferences), evolutionary processes (e.g. selection) and/or historical events may be responsible for differences in population genetic structuring and ultimately for the speciation of marine sister taxa (Palumbi 1994, Williams et al. 2001, Taylor & Hellberg 2005, Kelly et al. 2006).

Unraveling the effects of history, geography and biology requires a comparative approach between species differing in some aspects of their life-history. Such comparative studies have traditionally used distantly related species with a sympatric distribution (e.g. Avise 1992, Hellberg 1996, Bargelloni et al. 2005) or closely related sister taxa with different geographical distributions (Palumbi 1995, Sà-Pinto et al. 2005). Evidently, the large evolutionary and geographical differences between these species still fade the true pattern of genetic structure and speciation. In this way, cryptic radiations in the marine environment present an excellent opportunity to identify micro- and macro-evolutionary processes because they are likely to share a recent ancestor and are often sympatrically distributed (Dawson et al. 2002, Taylor & Hellberg 2005).

Cryptic species complexes are abundant in small invertebrates with a widespread distribution (Darling et al. 2004, Amato et al. in press, Gómez et al. 2007). Such transoceanic distribution is generally believed to be the result of either vicariance or dispersal events (Lessios et al. 1998). The discovery of cryptic radiations evidently questions the true cosmopolitanism of invertebrate species (Schroth et al. 2002, Le Gac et al. 2004) and corroborates the idea of very limited dispersal capacities. In contrast, evidence for long-distance dispersal has been documented in a saltwater rotifer (Suatoni et al. 2006) and in gastropods (Donald et al. 2005).

Marine nematodes are ubiquitously distributed around the world and typically outnumber other metazoan taxa in marine sediments in terms of density as well as diversity (Heip et al. 1985, Lamshead & Boucher 2003). Although many nematode species contain spectacular morphological differentiations, their detection often requires high resolution microscopy (De Ley 2000). This is further illustrated in the recent discovery of substantial 'cryptic' diversity in two geographically widespread nematode species (Derycke et al. 2005, Derycke et al. 2007a). Phylogeographical studies in nematode species are rare and restricted to terrestrial, parasitic species (Plantard & Porte 2004, Nieberding et al. 2005). The free-living marine nematode *Rhabditis (Pellioiditis) marina* (Bastian 1865) inhabits decomposing macroalgae deposited in the intertidal zone of coasts and estuaries around the world, and may therefore disperse over considerable distances through rafting. A population genetic survey in *R. (P.) marina* showed restricted gene flow on a fairly small geographical scale (< 100 km, Derycke et al. 2005), suggesting that dispersal through rafting is rather limited. The genetic structuring at the local scale may have been confounded, however, by colonisation-extinction dynamics typical of ephemeral populations (Derycke et al. 2007b).

The present study aims to identify global patterns of genetic diversity in the *R. (P.) marina* species complex, which currently includes seven morphologically and genetically recognized species (see Chapter 7). Morphological distinction requires a suite of several morphometric characteristics. At least six species are sympatrically distributed in the Southern Bight of the North Sea (Derycke et al. 2006). In combination with low dispersal abilities and a worldwide distribution, the *R. (P.) marina* complex forms an excellent model to investigate patterns of micro- and macro- evolution. Based on the cryptic diversity and restricted gene flow patterns at a local scale, we expected to find 1) several new cryptic species, and 2) a strong genetic structure within each species.

As in terrestrial species, marine organisms may show genetic patterns consistent with northwards range expansions after retreatment of the ice (e.g. Wares & Cunningham 2001, Gysels et al. 2004). Therefore, we expected

to find a Pleistocene signature in the global contemporary genetic structure, with 1) the genetic pattern of a postglacial northward range expansion in the NE Atlantic populations, and 2) a reduced genetic diversity at higher latitudes. Because of their longterm isolation, we also expected to find 3) a clear genetic break between Atlantic and Mediterranean populations. At the same time, these results contribute to the understanding of the cosmopolitan distribution and dispersal abilities of marine nematodes, which are hitherto poorly studied.

## MATERIAL AND METHODS

### SAMPLING AND GENETIC ANALYSIS

From June 2005 until October 2006, *R. (P.) marina* were collected from numerous localities throughout Europe (6 Baltic, 12 Atlantic and 7 Mediterranean localities), NE America (3), Canada (1), Mexico (1), South Africa (1) and Australia (1) (Table 9.1). Specimens of *R. (P.) marina* were isolated from the same habitat type: decaying seaweeds and/or seagrasses washed ashore in the intertidal zone (except for the Baltic and Mediterranean locations, where tidal activity is limited). The organic material was incubated on marine agar dishes, allowing nematodes to move into the agar. This facilitated identification and sorting of living nematodes under a binocular: *R. (P.) marina* were handpicked from the agar and preserved on acetone until molecular processing. This resulted in 639 nematodes collected from 31 localities worldwide. We also added published genetic data on *R. (P.) marina* from a fine-scale population genetic survey in Belgium and the southwestern part of The Netherlands (Derycke et al. 2005, 2006). We took haplotype frequencies from Derycke et al. (2006) from localities with  $n > 5$  and averaged them over seasons. Our total dataset thus comprised 1294 specimens from 42 localities (Table 9.1).

The mitochondrial cytochrome oxidase c subunit 1 (COI) gene was amplified according to Derycke et al. (2005). In short, DNA was extracted from single nematodes and 1  $\mu$ l was used for PCR with primers JB3 and JB5, yielding PCR-products of 426 bp long. These were screened for genetic variation with the Single Strand Conformation Polymorphism (SSCP) method. Distinct SSCP banding profiles were sequenced with the above primers on a ABI3130XL capillary DNA sequencer. Details on the sequencing procedure are described in Chapter 7. DNA samples were

stored at -80 °C so that different loci were amplified from the same individuals. We took a subset of samples containing representatives of each mitochondrial lineage and amplified two nuclear gene regions: the internal transcribed spacer region (ITS1-5.8S-ITS2) and the D2D3 region of the ribosomal LSU. Details on the amplification method can be found in Chapters 2 and 6. All new sequences will be deposited in GenBank.

DATA ANALYSIS

Phylogenetic analysis

COI sequences were aligned in ClustalX v 1.81 (Thompson et al. 1997) using default gap opening/extension costs of 15/6.66. Sequences of the closely related species *Rhabditis (Rhabditis) nidrosiensis* and of the congener *R. (P.) mediterranea* (Derycke et al. 2005) were added to the dataset. All 141 sequences were easily alignable and no indels were observed. Sequences were blasted in GenBank and translated in Mega v 3.0 (Kumar et al. 2004) to ensure sequence integrity.

Previous work on *R. (P.) marina* revealed high levels of regional genetic variation and the existence of a species complex (Derycke et al. 2005). To ensure that all sequences from our worldwide survey effectively belonged to this *R. (P.) marina* species complex, a neighbor-joining (NJ) tree using *P*-distances was constructed in Mega v 3.0 with trimmed COI sequences (396 bp). Three sequences (n = 2 for Florida, n = 1 for Mexico; haplotypes 18, 24 and 144 in Fig 9.1) were monophyletic and highly divergent with respect to all other rhabditid sequences (Fig 9.1). These misidentified nematodes were removed from the dataset. Mean sequence divergence within and between haplotype groups was calculated in Mega v 3.0 using the *P*-distance model.

The ITS alignment contained several indels and was screened for unreliable positions in SOAP 1.2a4 (Löytynoja & Milinkovitch 2001), which were removed for further phylogenetic analyses. The D2D3 contained no indels with respect to the *R. (P.) marina* complex and was aligned in ClustalX v1.81. For both nuclear fragments, a NJ tree was constructed using K2P-distances in Mega v 3.0.

The evolutionary model that best fitted the remaining mitochondrial and the nuclear sequences was determined with Modeltest 3.7 (Posada & Crandall 1998) using the Akaike Information Criterion (AIC). The HKY+I+G model best fitted the



COI data, GTR+I+G best fitted the D2D3 data, and GTR+G best fitted the ITS data. Most parsimonious (MP) trees were calculated using heuristic searches and a tree-bisection-reconnection branch swapping algorithm (10 000 rearrangements) with random stepwise addition of sequences in 100 replicate trials. Robustness of the trees was tested by bootstrapping with 1000 replications and 10 replicate trials of sequence addition. In addition, a Bayesian analysis was performed in MrBayes v 3.1.2 (Huelsenbeck & Ronquist 2005). MrModeltest 2.2 (Nylander 2004) identified the same evolutionary models as above. Four independent Markov chains were run for 500 000 generations, with a tree saved every 10th generation. The first 10 000 trees were discarded as burn-in.

**Table 9.1:** *Rhabditis (Pellioditis) marina*. Listing of the waterbasin, country and location of the sampled populations. The total number of sampled specimens (n) along with the number of specimens belonging to each species are indicated. Haplotype diversity (h) and the standard error are also shown.

Waterbasin	Country	Location	Code	Latitude	Longitude	PmI	PmII	PmIIa	PmIIb	PmIV	PmV	PmVI	PmVII	PmVIII	PmIX	PmX	n	
						n	h (SD)	n	h (SD)	n	h (SD)	n	h (SD)	n	h (SD)	n		h (SD)
Pacific Ocean	Queensland	Caïms	Au	16°55' S	145°45' E				27	0.52 (0.03)							27	
NW Atlantic	Mexico	Yucatan	Me	21°12' N	87°48' W												21	
NW Atlantic	USA	Florida	Fl	27°15' N	82°31' W			28	0.52 (0.03)								28	
Indian Ocean	South Africa	Transkei	Af	31°45' S	29°22' E							7	0.00 (0.00)				28	
Mediterranean	Greece	Crete	GrC	35°19' N	25°22' E							3	0.00 (0.00)				25	
NE Atlantic	Portugal	Tavira	Po	37°07' N	7°38' W									22	0.56 (0.10)		21	
Mediterranean	Spain	Alicante	Al	38°40' N	0°07' E						23	0.68 (0.08)					23	
NE Pacific	Canada	Vancouver Island	Ca	39°35' N	125°50' W						2	-					2	
NW Atlantic	USA	New York	NY	40°42' N	74°00' W			28	0.65 (0.05)								28	
Mediterranean	Spain	Palamos	Pa	41°50' N	3°07' E									29	0.58 (0.04)		29	
NW Atlantic	USA	Boston	Bo	42°21' N	71°03' W			30	0.56 (0.09)								30	
Mediterranean	Croatia	Mljet Islands	CrM	42°44' N	17°32' E									19	0.72 (0.08)		19	
Mediterranean	Greece	Lagonissi	GrL	42°44' N	25°53' E						22	0.80 (0.06)					22	
NE Atlantic	Spain	San Pedro	San	43°23' N	8°17' W					10	0.00 (0.00)						10	
Mediterranean	France	St Aygulf	Ay	43°23' N	6°43' E							11	0.76 (0.08)				11	
Mediterranean	Croatia	Brodarica	CrB	43°40' N	15°56' E									28	0.60 (0.06)		28	
NE Atlantic	France	Vaux sur mer	Va	45°38' N	1°04' W		3	-	16	0.00 (0.00)							19	
NE Atlantic	France	Sables d'Orlonne	Sa	46°29' N	1°46' W		10	0.78 (0.09)				14	0.82 (0.06)				24	
English Channel	France	St Malo	Ma	48°38' N	2°01' W			39	0.75 (0.02)								39	
English Channel	France	Roscoff	Ro	48°43' N	3°59' W	1	-			1	-			21	0.83 (0.06)		23	
English Channel	Great Britain	Plymouth	Pl	50°22' N	4°9' E			31	0.74 (0.04)								31	
North Sea	Belgium	Nieuwpoort	Ni	51°09' N	2°43' E	44	0.84 (0.02)	2	-	16	0.43 (0.13)						62	
North Sea	Belgium	Blankenberge *	Bl	51°19' N	3°8' E	27	0.51 (0.11)	28	0.92 (0.03)	24	0.68 (0.04)						86	
North Sea	The Netherlands	Paulina *	Pa	51°21' N	3°49' E	43	0.87 (0.03)	17	0.83 (0.05)	12	0.62 (0.09)	5	0.00 (0.00)			2	0.00 (0.00)	72
North Sea	The Netherlands	Kruispolderhaven *	Kr	51°22' N	4°3' E	48	0.67 (0.04)										48	
North Sea	The Netherlands	Zeedorp *	Za	51°24' N	3°58' E	43	0.78 (0.05)			32	0.74 (0.05)						75	
North Sea	The Netherlands	Breskens *	Br	51°24' N	3°33' E	49	0.68 (0.06)										49	
North Sea	The Netherlands	Soehaven *	Si	51°27' N	3°36' E	41	0.79 (0.04)	17	0.23 (0.13)	36	0.70 (0.05)						94	
North Sea	The Netherlands	Oosterschelde *	Os	51°36' N	3°50' E	46	0.63 (0.07)										63	
North Sea	The Netherlands	Lake Grevelingen-Brouwershaven *	GrB	51°44' N	3°57' E	24	0.87 (0.05)	15	0.56 (0.01)								72	
NE Atlantic	Ireland	Cork	Co	51°53' N	8°23' W					33	0.62 (0.06)						7	
North Sea	The Netherlands	Lake Grevelingen-Scharendijke	GrS	51°54' N	3°49' E					5	0.80 (0.16)			2	0.00 (0.00)		29	
NE Atlantic	Great Britain	Wales	Wa	53°24' N	4°19' W			11	0.00 (0.00)								11	
Baltic Sea	Germany	Kiel	Ki	54°19' N	10°08' E			1	-		1	-					2	
Baltic Sea	Poland	Isle of Rugla	Ru	54°30' N	13°24' E			9	0.22 (0.17)								9	
Baltic Sea	Poland	Hel	He	54°36' N	18°48' E			4	-			10	0.69 (0.10)				14	
Baltic Sea	Poland	Kuznica	Ku	54°43' N	18°35' E			19	0.49 (0.10)								19	
Baltic Sea	Germany	Flensburg	Fl	54°46' N	9°26' E			21	0.65 (0.07)								21	
Baltic Sea	Germany	Sylt	Sy	55°01' N	8°26' E			9	0.42 (0.19)			10	0.71 (0.12)				19	
North Sea	North Scotland	Westroy	Sc	59°17' N	2°57' W	10	0.47 (0.13)	15	0.69 (0.07)								25	
North Sea	Norway	Aurlandsvangen	No	60°54' N	7°10' E			29	0.42 (0.11)								29	
Atlantic	Iceland	Prestbakki	ic	65°19' N	21°13' W	20	0.50 (0.12)			1	-						21	
TOTAL						372	289	254	27	79	79	29	23	98	21	23	1295	

\* averaged across seasons (data from Derycke et al. 2006)

### Phylogeographic and genetic structure analyses

A haplotype network was constructed using the minimum spanning network method in Arlequin v 2.0 (Schneider et al. 2000), and the statistical parsimony procedure in the program TCS v1.13 (Clement et al. 2000). Haplotypes were connected at the 95 % confidence level and ambiguities in the network were resolved according to the predictions of Crandall & Templeton (1993).

Based on concordance among phylogenetic trees and on previously reported genetic and morphological differentiation in *R. (P.) marina* (Derycke et al. 2005, Chapters 5 and 6), the mitochondrial sequence data were divided such that all sequences forming a monophyletic lineage were treated as species (see results). For each of these species, haplotype ( $h$ ) and nucleotide ( $\pi$ ) diversity and their standard deviation were calculated for each locality with Arlequin 2.0 (Schneider et al. 2000).

Patterns of genetic structuring among geographical localities ( $n > 5$ ) for each species were estimated using Analysis of Molecular Variance (AMOVA). Significance levels were determined with 1000 permutations. Pairwise  $\Phi_{ST}$  values among localities (and among regions) were calculated using Tamura & Nei distances (Tamura & Nei 1993). Due to low sample sizes and/or geographical restriction to one locality, AMOVA was not performed for the species PmVI, PmVII, PmIX and PmX<sup>25</sup>. For the other six species, additional geographical structuring was investigated with a spatial analysis of molecular variance using SAMOVA 1.0 (Dupanloup et al. 2002). This procedure defines groups of populations that are geographically homogeneous and maximally differentiated from each other. In addition, pairwise  $\Phi_{ST}$  values were calculated among populations.

The underlying patterns responsible for the genetic substructuring were investigated with a Nested Clade Analysis (NCA) using the program GeoDis 2.5 (Posada et al. 2000) on the parsimony network obtained with TCS. The NCA procedure assesses geographic association between haplotypes and uses the information embedded in the haplotype network to discriminate between historical events (e.g. fragmentation, expansion) and contemporary processes (e.g. gene flow)

---

<sup>25</sup> In Chapter 6, we found that lineages Z, Z2, Z3 and Z4 are cryptic species within the *R. (P.) marina* complex. We here renamed them according to the other cryptic species within the complex: Z = PmVI; Z2 = PmX; Z4 = PmIX. Because we currently have very limited information on Z3 (see Chapters 3 and 6), we do not discuss it further in this chapter.

responsible for the observed pattern of genetic variation (Templeton et al. 1995). The nesting design was constructed by hand on the parsimony network following the rules given in Templeton et al. (1987) and Templeton & Sing (1993). The statistical significance of the NCA distance measures was calculated by comparison with a null distribution derived from 1000 random permutations of clades against sampling localities. The NCA was restricted to PmII because it was the only species with an adequate sample design (i.e. geographical distribution and sample size).

### Demographic analyses

The frequency distribution of pairwise sequence differences for each species was analysed by mismatch analysis and compared to the expected distribution under a sudden expansion model using 100 bootstrap replicates and quantifying the sum of squared deviations between observed and expected distributions (Rogers & Harpending 1992). The associated parameters ( $\tau$ ,  $\theta_0$ ,  $\theta_1$ ) were also calculated. In addition, Tajima's D (Tajima 1989) and Fu's  $F_s$  (Fu 1997) neutrality test were performed to infer whether sequence evolution in the species was neutral. Significant negative values of both statistical tests indicate that the species has recently expanded. When all tests indicated a population expansion, the corresponding  $\tau$  value was used to infer the mutation rate of COI (Pinceel et al. 2005) using the equation  $\tau = 2 u t$ , where  $u$  is the mutation rate of COI and  $t$  the time since expansion (Rogers & Harpending 1992). For this, we assumed that the expansion occurred during the interglacial periods (Weichselian, Eemian or Saalian), i.e. 14, 130 or 240 ky BP.

## RESULTS

### PHYLOGENETIC ANALYSIS

The screening of the COI gene in 640 specimens collected from around the world yielded 94 haplotypes, 83 of which not previously reported. The complete dataset (i.e. including Belgian and Dutch samples from Derycke et al. 2006) yielded a total of 1295 screened specimens and 136 haplotypes. The 396 bp long fragment contained 131 (33.1 %) variable sites, 103 of which were parsimony informative. Not all substitutions were synonymous, and the amino acid alignment yielded 11 polymorphic sites (8.3 % variable sites), one of which was fixed in two species (PmI and PmIV) and nearly fixed in a third (PmIII).

Phylogenetic analyses of the mitochondrial and nuclear genes identified eleven highly supported lineages (PmI – PmX, PmIIIb), that were monophyletic with respect to *R. (R.) nidrosiensis* in the NJ analysis (Fig 9.1). The congener *R. (P.) mediterranea* was mixed among the *R. (P.) marina* species. The taxonomic status of the Z3 branch has been discussed in Chapter 6 and because of the limited number of specimens and data on this branch, we do not treat it further here. The mitochondrial lineages PmVI and PmIX collapsed into a single well supported clade in the nuclear gene trees. This pattern was also observed for PmVII and PmVIII. Nevertheless, we treat these four mitochondrial lineages as species based on their allopatric distribution (see next section). In addition, morphological differences between PmVI and PmIX have been documented (see chapter 6). A substructuring within the mitochondrial clades PmIII (subclades a and b) and PmV (subclades a, b and c) was present (Fig 9.1A). For PmV, this structuring could not be attributed to geography and it was absent in the nuclear genes (Fig 9.1B and C). We therefore treated the three subclades as intraspecific variation of PmV. Subclade b of PmIII was highly supported in the nuclear genes, and was found allopatrically from subclade a. PmIIIb was thus also treated as a species. The single individual from Canada did not belong to any of these eleven species. Haplotypes within each species were very similar (divergence 1.0 - 2.6 %), while haplotypes from different species were separated by at least 17 substitutions (divergence 4.4 – 12.7 %, Table 9.2).

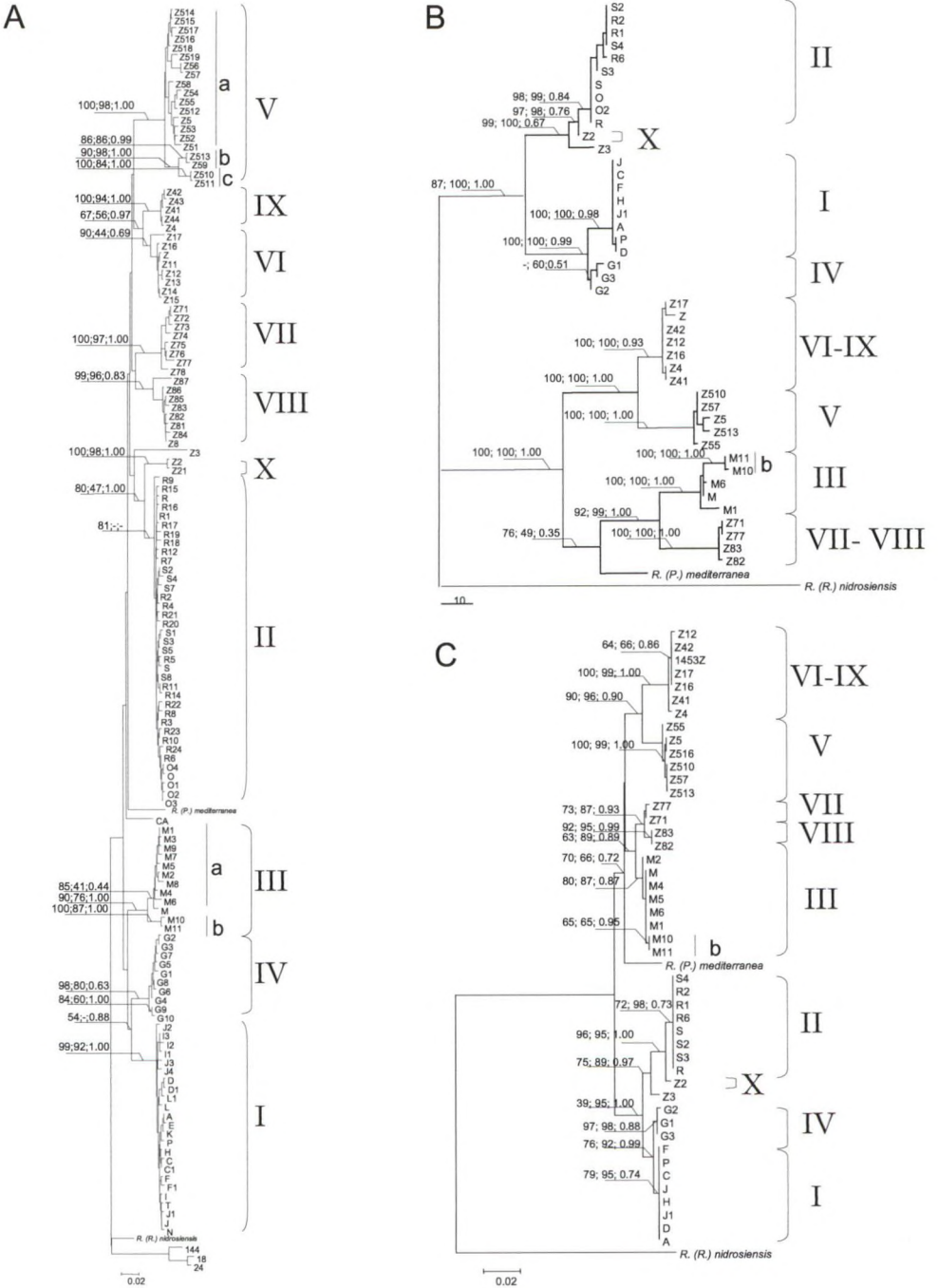

**Fig. 9.1:** *Rhabditis (Pellioiditis) marina*. A. Neighbor-joining (NJ) tree of COI based on P-distances. B. NJ tree of the ITS region based on K2P distance. C. NJ tree of the D2D3 region based on K2P distances. Values above branches are bootstrap values for MP, NJ and Bayesian probabilities. Cryptic species are designated with roman numerals.

	PmI	PmII	PmIIIa	PmIIIb	PmIV	PmV	PmVI	PmVII	PmVIII	PmIX	PmX	Z3	Ca	<i>R. (P.) med</i>	<i>R. (R.) nidro</i>
PmI	1.0 ± 0.2														
PmII	8.8 ± 1.4	1.0 ± 0.2													
PmIIIa	7.8 ± 1.3	8.8 ± 1.4	1.0 ± 0.2												
PmIIIb	8.2 ± 1.3	9.1 ± 1.3	3.3 ± 0.8	0.5 ± 0.3											
PmIV	6.6 ± 1.1	7.9 ± 1.3	7.0 ± 1.2	7.2 ± 1.2	1.0 ± 0.3										
PmV	9.9 ± 1.4	9.1 ± 1.3	8.7 ± 1.3	9.4 ± 1.3	9.0 ± 1.3	2.6 ± 0.5									
PmVI	10.1 ± 1.5	7.0 ± 1.2	7.2 ± 1.2	7.8 ± 1.2	8.1 ± 1.3	8.5 ± 1.3	1.2 ± 0.3								
PmVII	9.8 ± 1.4	8.3 ± 1.2	8.7 ± 1.3	9.2 ± 1.4	10.7 ± 1.5	9.8 ± 1.4	7.4 ± 1.2	1.5 ± 0.4							
PmVIII	9.7 ± 1.5	7.8 ± 1.3	7.4 ± 1.2	7.4 ± 1.2	9.1 ± 1.4	9.7 ± 1.4	7.9 ± 1.3	8.1 ± 1.3	1.4 ± 0.3						
PmIX	9.6 ± 1.4	7.4 ± 1.2	7.6 ± 1.2	7.3 ± 1.2	9.3 ± 1.4	8.4 ± 1.2	4.4 ± 0.9	8.0 ± 1.2	7.9 ± 1.2	0.5 ± 0.2					
PmX	10.2 ± 1.6	4.7 ± 1.0	9.1 ± 1.4	8.8 ± 1.3	9.0 ± 1.4	9.5 ± 1.4	7.7 ± 1.3	8.0 ± 1.3	9.3 ± 1.4	7.8 ± 1.3	0.5 ± 0.3				
Z3	11.4 ± 1.5	9.0 ± 1.4	11.2 ± 1.5	12.0 ± 1.6	11.0 ± 1.5	11.6 ± 1.5	10.1 ± 1.5	10.7 ± 1.5	11.4 ± 1.6	11.3 ± 1.5	10.6 ± 1.6				
Ca	9.2 ± 1.5	7.0 ± 1.2	6.7 ± 1.2	6.6 ± 1.2	8.2 ± 1.3	9.4 ± 1.4	7.7 ± 1.3	8.0 ± 1.3	8.3 ± 1.3	8.3 ± 1.4	7.7 ± 1.3	9.7 ± 1.5			
<i>R. (P.) med</i>	10.5 ± 1.4	8.0 ± 1.3	8.0 ± 1.3	8.6 ± 1.4	9.3 ± 1.4	9.8 ± 1.4	6.7 ± 1.2	10.0 ± 1.4	9.6 ± 1.4	8.8 ± 1.4	8.6 ± 1.4	11.7 ± 1.6	7.6 ± 1.4		
<i>R. (R.) nidro</i>	7.8 ± 1.3	8.3 ± 1.3	8.0 ± 1.3	8.3 ± 1.3	8.5 ± 1.3	10.7 ± 1.4	9.2 ± 1.4	9.9 ± 1.4	9.6 ± 1.4	8.0 ± 1.3	9.3 ± 1.4	12.7 ± 1.7	8.1 ± 1.4	9.1 ± 1.4	

**Table 9.2** Sequence divergences within and between species of the *R. (P.) marina* complex. Mean within-group sequence divergence ± standard error (diagonal) and mean between-group divergences ± standard error are based on the P-distances. Sequences Z3, *R. (P.) mediterranea* (*R. (P.) med*) and *R. (R.) nidrosiensis* (*R. (R.) nidro*) are from Derycke et al. (2005) and Chapter 6.

PHYLOGEOGRAPHY OF THE *R. (P.) MARINA* SPECIES COMPLEX

The species showed a dominant pattern of sympatry in the Atlantic samples, while Mediterranean samples mostly contained one species (Fig. 9.2). Three species were highly abundant: PmI was almost exclusively present in the North Sea, while PmII showed a continuous range from the Bay of Biscay to the Baltic Sea. PmIII was less abundant in this range, but it was the dominant species along the east coast of North America, yielding a transatlantic distribution range (Fig. 9.2). PmIIIb was found in Australia. PmIV was also widespread along the European Atlantic, with the exception of the Baltic region. None of these five species were encountered in the Mediterranean samples, which were dominated by PmV and PmVIII. The latter species was restricted to the Mediterranean Sea. PmV on the other hand had a very discontinuous distribution range: in addition to the Mediterranean, it was encountered in Po, Sy and in the Baltic samples, but was absent in any intermediate Atlantic locality. The remaining four species (PmVI, PmVII, PmIX, PmX) were only sampled at low frequencies (Fig. 9.2). PmVI was found in the North Sea, Bay of Biscay, Mediterranean and South Africa. PmVII was restricted to the English Channel and PmIX to Mexico. Finally, PmX was found in the North Sea and South Africa.

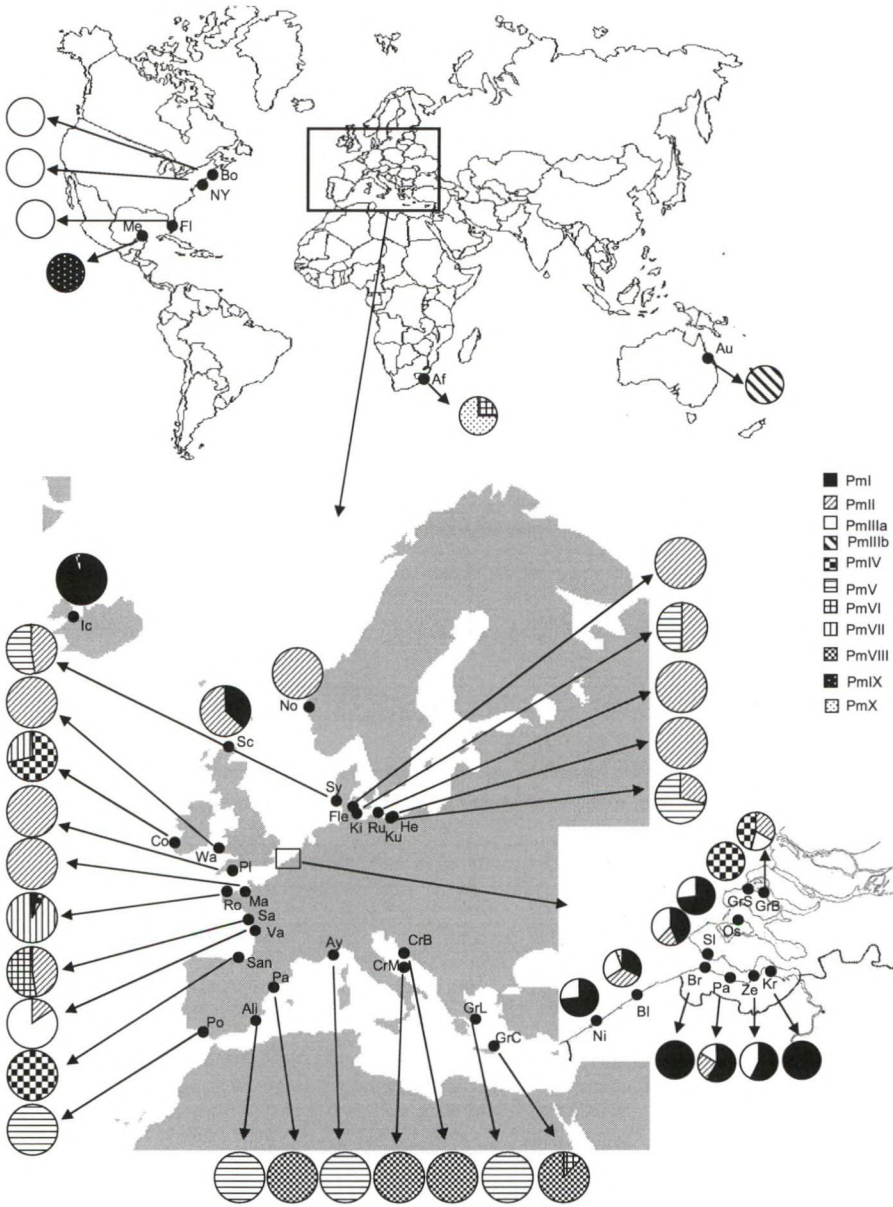

Fig. 9.2 *Rhabditis (Pellioiditis) marina*. Distribution of the eleven cryptic species in the sampled localities. Abbreviations of localities are as in Table 9.1



SPATIAL GENETIC STRUCTURING WITHIN THE CRYPTIC SPECIES

Pairwise  $\Phi_{ST}$  values for each species are summarized in Appendix 9.1. AMOVA indicated the presence of a significant genetic structuring in PmI, PmII, PmIIIa, PmIV, PmV and PmVIII (Table 9.3), and SAMOVA detected an additional geographical structuring in PmI and PmII. For PmI, 43.85 % of the genetic variation was significantly attributed to a grouping of Iceland/North Scotland and the Belgian/Dutch samples. For PmII, one location from the Westerschelde (SI) and samples from the NE North Sea (Sy) and Baltic Sea (Fl, Ku, Ru) were highly differentiated from each other and from all other samples (Appendix 9.1). Nevertheless, a grouping of No, Sc, Wa, Sy, Fle, Ku, Ru into a northern group and of SI, Bl, Gr, Pa, Pl, Ma, Sa into a southern group explained an additional 19.3 % of the observed genetic variation in PmII ( $p < 0.001$ ).

		n	%	$\Phi_{st}$	p
PmI	Among populations	370	22.35	0.22	***
	Within populations		77.65		
PmII	Among populations	281	36.91	0.37	***
	Within populations		63.09		
PmIII	Among populations	281	62.54	0.63	***
	Within populations		37.46		
PmIV	Among populations	77	60.29	0.60	***
	Within populations		39.71		
PmV	Among populations	76	39.31	0.39	***
	Within populations		60.69		
PmVIII	Among populations	98	27.56	0.27	***
	Within populations		72.44		

**Table 9.3** *Rhabditis (Pellioiditis) marina*. AMOVA results for the species occurring in several locations and with  $n > 5$ . The number of individuals in the analysis (n), the amount of variation explained by differences among and within populations (%), the  $\Phi$  statistics and the significance level (p) are shown. \*\*\*  $p < 0.001$ .

The highest amount of variation was observed between populations of PmIV and the lowest between populations of PmIIIa (60 % and 20 %, respectively, Table 9.3). Given the transoceanic distribution of PmIII, this low genetic differentiation was surprising. Pairwise  $\Phi_{ST}$  values between PmIIIa populations on both sides of the Atlantic generally were low and non-significant

(Appendix 9.1). The structuring was mainly caused by the Bay of Biscay location (Va), which was in most cases differentiated from the locations in Belgium and The Netherlands. Similarly, a strong genetic differentiation was observed for PmIV between the Bay of Biscay (San) and all other locations. The single haplotype that was encountered in Iceland was more closely related to the haplotypes from The Netherlands and Cork than it was to the Biscay haplotypes, while the opposite was true for the Roscoff haplotype (Fig. 9.3).

For PmV, the northern samples Sy and He were not significantly differentiated from each other, while the southern populations (Po, GrL, and Ay) were (Appendix 9.1). Interestingly, the Po sample was not significantly differentiated from the northern Sy sample, and the Baltic sample (He) not from the Mediterranean Ay sample. Finally, low but significant  $\Phi_{ST}$  values were noticed between all four Mediterranean populations of PmVIII.

*PHYLOGEOGRAPHY AND DEMOGRAPHIC HISTORY OF THE CRYPTIC SPECIES*

The maximum parsimony network yielded several unconnected haplotypes and/or haplotype groups corresponding to the different phylogenetic species (Fig. 9.3). Of all haplotypes, 57 were shared among sampling localities and 79 haplotypes were location specific. PmI and PmII, and to a lesser extent PmIIIa, PmVI and PmVIII, displayed a star shaped network (Fig. 9.3). The tip haplotypes of all networks were largely constrained to a particular geographic region, while central haplotypes of lineages PmII and PmIIIa were shared among populations throughout their distribution.

The goodness-of-fit test of the mismatch distributions showed that six out of the nine mitochondrial clades fitted a model of sudden expansion (Table 9.4), but Tajima's D and Fu's Fs were significantly different from zero and negative only for clade PmII. We used the mismatch distribution parameter  $\tau$  accompanying the expansion of PmII to calculate the divergence rate of the COI gene, assuming that the approximate time of expansion occurred after one of the last three glacial periods. This yielded divergence rates of 21.7 %, 2.3 % and 1.3 % per MY, respectively.

	PmI	PmII	PmIIIa	PmIV	PmV	PmVI	PmVII	PmVIII	PmIX
Mismatch mean	2.84	2.5	1.78	3.43	9.8	1.86	5.12	1.81	1.14
$\theta_0$	0.001	0.52	0.0	0.012	3.01	0	0.002	0	0
$\theta_1$	14.62	8.8	3.16	4.37	24.1	470	21.12	19.9	1892
$\zeta$	3.69	2.41	2.94	9.1	10.3	2.14	6.9	2.33	1.28
SSD (p)	0.04 ***	0.001 (ns)	0.08 (ns)	0.04 (ns)	0.01 (ns)	0.006 (ns)	0.05 (*)	0.04 (***)	0.007 (ns)
Raggedness(p)	0.09 ***	0.016 (ns)	0.32 (*)	0.08 (ns)	0.02 (*)	0.05 (ns)	0.08 (ns)	0.11 (*)	0.11 (ns)
Tajima's D (p)	-0.76 (ns)	-1.59 *	-0.006 (ns)	1.13 (ns)	1.43 (ns)	0.41 (ns)	0.92 (ns)	0.4 (ns)	0.08 (ns)
Fu's Fs (p)	-4.5 (ns)	-26.04 ***	1.91 (ns)	1.10 (ns)	1.1 (ns)	-1.22 (ns)	1.26 (ns)	0.82 (ns)	-0.71 (ns)

**Table 9.4** *Rhabditis (Pellioiditis) marina*. Mismatch distribution parameters and results of Tajima's and Fu's neutrality tests. The significance level is indicated between brackets. (ns) not significant, \*  $p < 0.05$ , \*\*  $p < 0.01$ , \*\*\*  $p < 0.001$ .

**Fig. 9.3** *Rhabditis (Pellioiditis) marina*. TCS network with 95 % confidence connection between haplotypes. Circles are proportional to haplotype abundances and are shaded according to geographical occurrence. Small empty circles are hypothetical mutations.

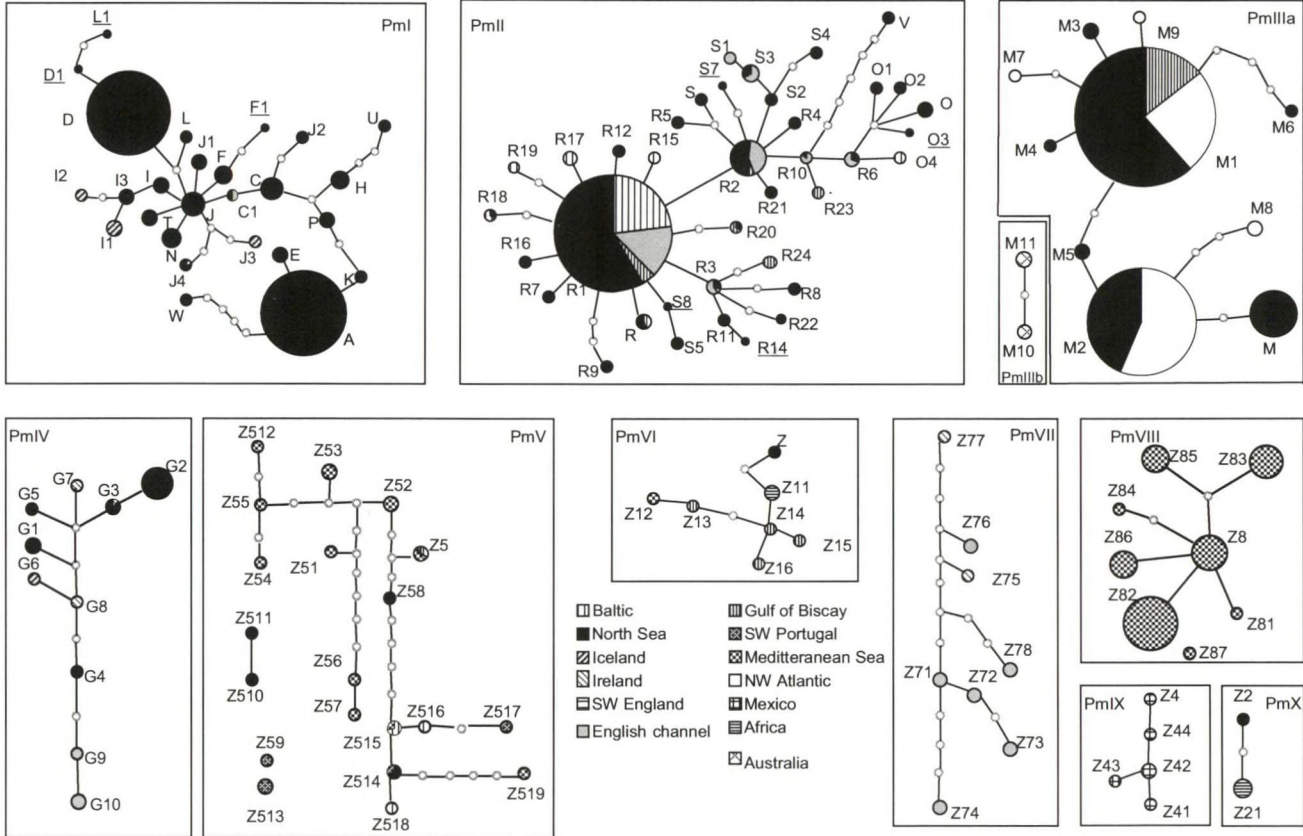

*NESTED CLADE ANALYSIS OF PmII*

The nesting procedure on the TCS network of the PmII haplotypes resulted in three clade levels (Fig. 9.4). NCA detected a significant association between genetic variability and geographic distribution for several clades at all clade levels (Table 9.5, Fig. 9.4). At the lowest nesting group, genetic variation was mainly the result of restricted gene flow with isolation by distance (clades 1-1, 1-14). This pattern was observed almost throughout the entire distribution range of PmII: the Bay of Biscay, English Channel, North Sea and Baltic Sea. In addition, a recent contiguous range expansion was detected from the Bay of Biscay through the English Channel in the northern part of the North Sea (clade 1-11). For clade 1-19, some evidence for IBD was found, but the pattern could not be distinguished from range expansion and fragmentation due to inadequate sampling.

At the higher nesting levels, restricted gene flow with isolation by distance remained the dominant underlying pattern for the observed genetic variation, although some evidence was present for occasional long distance dispersal between the Bay of Biscay and the northern part of the North Sea (clade 2-1). The 2-3 clade was found along the SW and N coasts of Great Britain, in Norway and in Sylt, and NCA detected a signal of range expansion along Great Britain (Fig. 9.5A). There was, however, insufficient genetic resolution to distinguish between range expansion and restricted gene flow.

The total cladogram consisted of three clades, the oldest being the interior 3-2 clade which was abundant from the southernmost location (Va) over the English Channel and the SW part of the North Sea. The younger 3-1 tip clade dominated the British Isles, the Baltic region and the North Sea. The 3-3 clade overlapped with the 3-1 and 3-2 clades in the English channel and the southern part of the North Sea (Fig. 9.5B). According to the NCA, the distribution of the three-level clades was caused by a range expansion.

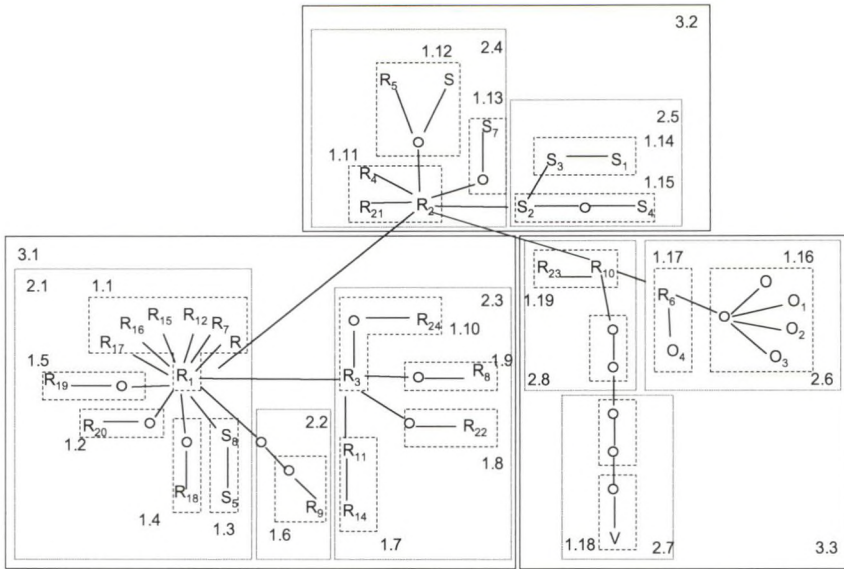

**Fig. 9.4** *Rhabditis (Pellioditis) marina*. TCS network among the PmII haplotypes with indication of the nesting design used in the Nested Clade Analysis.

Clade	Chi-square	P	Inference	
1-1	336.9	< 0.0001	1-2-3-4-No	Restricted gene flow with isolation by distance
1-3	2.0	1.0		
1-7	5.0	0.21		
1-10*	11.0	0.19		
1-11	42.0	< 0.0001	1-2-11-Yes-12-No	Contiguous range expansion
1-12	6.0	0.06		
1-14	20.0	< 0.0001	1-19-20-2-11-17-4-No	Restricted gene flow with isolation by distance
1-15	4.95	0.06		
1-16	55.0	< 0.0001		No interior tips
1-17	12.0	0.08		
1-19	11.0	0.002	1-2-3-5-15-16-18-No	Geographical sampling scheme inadequate to discriminate between fragmentation, range expansion, and isolation by distance
2-1	123.6	0.001	1-2-3-5-6-7-8-No	Sampling design inadequate to discriminate between isolation by distance (short distance movements) versus long distance dispersal
2-3*	72.0	< 0.0001	1-2-3-5-6- Too few clades	Insufficient genetic resolution to discriminate between range expansion/colonization and restricted dispersal/gene flow
2-3*	72.0	< 0.0001	1-2-3-5-6-Too few clades	Insufficient genetic resolution to discriminate between range expansion/colonization and restricted dispersal/gene flow
2-4	22.9	0.09		
2-5	27.4	< 0.0001	1-2-3-4-No	Restricted gene flow with isolation by distance
2-6	28.7	< 0.0001	1-2-19-20-2-3-4-No	Restricted gene flow with isolation by distance
3-1	72.9	0.01	1-2-3-4-No	Restricted gene flow with isolation by distance
3-2	7.71	0.36		
3-3	20.3	0.10		
Total	264.4	< 0.0001	1-2-11-Yes	Range expansion

**Table 9.5** Inferences from the Nested Clade Analysis using the nesting design in Fig. 9.4 (see Templeton 1998 for details). \* alternative connection possible, but with the same results.

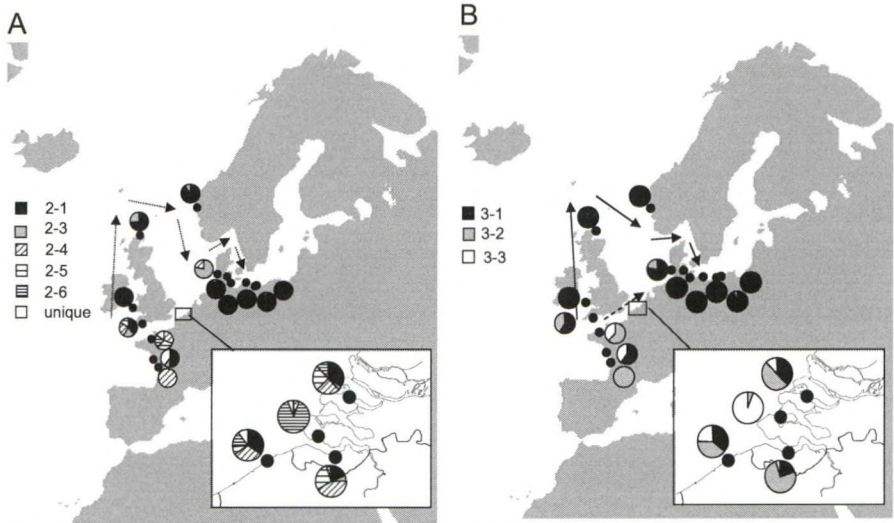

**Fig 9.5:** Geographical distribution of the 2- and 3-step clades of PmII. (A) Distribution of the 2-step clades with indication of the possible range expansion of clade 2-3. (B) Distribution of the 3-step clades with indication of their range expansions. The clades are the result of the NCA and are shown in Fig 9.4

*HAPLOTYPE DIVERSITY IN PmII*

The haplotype diversity of PmII shows a slight decreasing trend with latitude (Fig. 9.6). The higher  $h$  was observed in the southernmost populations and was slightly lower in the Baltic and northern North Sea populations (except in locations Fle and Sc). The diversity in the Southern Bight of the North Sea and the Brittany populations is, however, not significant lower than in the southern populations.

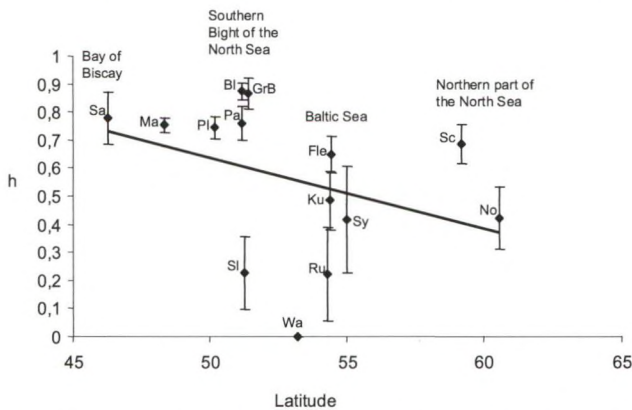

**Fig. 9.6** *Rhabditis (Pellioiditis) marina*. Haplotype diversity ( $h$ ) of PmII across latitude. Error bars are standard deviations. Geographical regions are indicated, sample abbreviations are as in Table 9.1.

## DISCUSSION

*R. (P.) marina* is composed of at least 11 genetically highly divergent lineages, seven of which have previously been designated as 'cryptic' species based on molecular and morphological data (Chapters 5 and 6). Lineages PmIIIb, PmV, PmVII and PmVIII are new in this study. Based on concordance patterns between mitochondrial and nuclear gene trees and geographical distribution, these four new lineages were considered additional cryptic species within the *R. (P.) marina* complex. Morphological data are required to confirm this hypothesis.

### *MICR- EVOLUTIONARY PROCESSES AFFECTING POPULATION GENETIC STRUCTURE*

#### Gene flow and migration

Based on the genetic patterns on a local scale (Derycke et al. 2006, 2007a), we expected deep levels of population structure in all species of the *R. (P.) marina* complex on a global scale. Indeed, a highly significant structuring was observed in all cryptic species of sufficient sample size, indicating that gene flow is limited between populations within the *R. (P.) marina* complex. Based on the  $\Phi_{st}$  values, we infer two general patterns of dispersal. Significantly high pairwise  $\Phi_{st}$  values were observed between populations from different biogeographical areas (e.g. between the northern part and the Southern Bight of the North Sea for PmI, between the Baltic and the North Sea locations for PmII) while non-significant values were observed between geographically proximate populations (e.g. in the Westerschelde estuary). There were, however, some exceptions to this general pattern. For example, no differentiation was observed between some NE and NW Atlantic populations of PmIIIa and between Baltic and Mediterranean populations of PmV. In addition, the transcontinental distribution of PmIII, PmVI and PmX suggests that effective long-distance dispersal has occurred in at least some species of the *R. (P.) marina* complex. In the case of PmIII, the presence of two haplotypes (M1, M2) at relatively high abundances on both sides of the Atlantic may be explained by multiple colonisation events or by a large dispersal propagule (Wares & Cunningham 2001). In view of its life-history characteristics, *R. (P.) marina* could indeed disperse over considerable distances by rafting on macroalgae, which may be the only possible means of dispersal over large stretches of ocean for marine intertidal species with direct development. The

importance of rafting in the marine environment has been recognized (Thiel & Gutow 2005, Vandendriessche et al. 2006) and rafting has been proposed for several intertidal marine invertebrates lacking long-lived larvae (Ó Foighil et al. 1999, Thiel & Gutow 2005, Donald et al. 2005). The NCA results in PmII showed, however, that long-distance dispersal only occurs sporadically. This is further strengthened by the presence of unique haplotypes in the distant populations of PmIII, PmVI and PmX, and by the lack of a transcontinental distribution in the other lineages. Therefore, a large dispersal propagule with many haplotypes may be the best explanation for the transatlantic pattern in PmIII. In view of the present watercurrents between Europe and America, this dispersal event probably occurred when both continents were connected via watercurrents. Alternatively, dispersal may have been mediated through the transport of ship ballast water or through migrating birds on a contemporary timescale.

Additional geographical structure was observed in PmI and PmII, in which northern populations of the North Sea and/or Baltic Sea were genetically more similar to each other than to the southern populations of the English Channel and Bay of Biscay. This genetic break coincided around the British Isles in all Atlantic species, suggesting that the genetic structure in the *R. (P.) marina* species was influenced by historical events.

### Historical events

The dramatic climate changes of the last few million years, with extensive oscillations during the last 700 ky, are probably one of the most important historical events influencing the distribution of many temperate species (Taberlet et al. 1998). The low temperatures accompanying the Pleistocene glaciations shifted the distribution area of many temperate species southwards (Hewitt 1996). Recent studies show that historical glaciations also affected marine species, with evidence for postglacial range expansions (Wares & Cunningham 2001, Gysels et al. 2004) and multiple refugia along the Atlantic coasts of Western Europe and Great Britain (Coyer et al. 2003, Jolly et al. 2005, Remerie et al. 2006b). Moreover, the sea level drops were responsible for long-term isolation of many marine populations. In the Northwest Atlantic for example, closure of the Strait of Gibraltar isolated populations in the Mediterranean Sea, while NW Europe and the British Isles were largely covered with ice (Dawson 1992). Due to their relatively young age, North European



populations are typically less diverse than their southern counterparts (Hewitt 2000). In view of the limited dispersal in nematodes, we expected to find a clear signature of the Pleistocene glaciations in *R. (P.) marina*.

Several observations indeed indicate that Pleistocene climate changes have affected the population structure of PmII. The mismatch distribution and NCA showed a clear pattern of population expansion, which occurred in two phases: a recent expansion was observed through the English Channel into the North Sea (clade 1-11), and an older expansion along the western and northern coasts of the U.K., into the northern part of the North Sea and the Baltic Sea (Fig. 9.5). Together with the genetic break around the British Isles in all other *R. (P.) marina* species, this suggests that the oldest expansion of PmII occurred before the last Pleistocene glaciation when the landbridge between England and France formed an important barrier for migration into the North Sea (ca. 20 ky BP). The younger expansion then occurred after the formation of the English Channel, some 7.5 ky BP. Similarly, the colonisation of the Baltic Sea postdated 7.5 ky BP and probably consisted of propagules from the oldest expansion event around the British Isles. The distribution of three-level clades highly overlaps in the Southern Bight of the North Sea, which may be indicative of a contact zone between clades from these two expansions. Such a contact zone has also been suggested for the mysid *Neomysis integer* (Remerie et al. 2006b), for the common goby *Pomatoschistus microps* (Gysels et al. 2004), for the brown trout *Salmo trutta* (Garcia-Marin et al. 1999) and for the polychaete *Pectinaria koreni* (Jolly et al. 2005).

A general trend of declining genetic diversity with latitude has been observed in northern temperate species as a result of founder events during expansions (Hewitt 2000, Avise 2000). This pattern was present in *R. (P.) marina*, however, levels of genetic diversity were not significantly lower in the Southern Bight of the North Sea and in Brittany compared to the southern populations. The Southern Bight of the North Sea has intensively been sampled which may confound the diversity estimates in this region. However, haplotype diversity analysed by season was generally high (Derycke et al. 2006) and therefore represents the actual diversity in this area. This high genetic diversity may be explained by a refugial zone around Brittany (Provan et al. 2004) or by a recolonisation from several southern refugia (see Coyer et al. 2003). The distinction between both requires additional sampling in this area. Alternative explanations like massive range shifts through extensive dispersal (Olsen et al. 2004) or slow colonisation with a high proportion of individuals dispersing over small

distances in a continuous front (Nichols & Hewitt, 1994) are unlikely due to the clear signal of range expansion and the limited dispersal of *R. (P.) marina*. Within the Baltic, haplotypic diversity is highest in the Beltic Sea (Fle) and gradually decreases into the western Baltic (Fig 9.6). Pairwise  $\Phi_{st}$ -values between each of the northern North Sea samples (Sc, No and Sy) and the three Baltic samples (Fle, Ku and Ru) are highest when the western most Baltic sample (Ru) is involved (Appendix 9.1). These patterns correspond with founder events following colonisation from The North Sea and have also been observed in microsatellite data from cod (Nielsen et al. 2003), turbot (Nielsen et al. 2004) and herring (Bekkevold et al. 2005).

Many marine species show distinct genetic breaks between Atlantic and Mediterranean populations, which were isolated from each other due to drastic sea level drops during the last glacial maximum (Remerie et al. 2006a, Sà-Pinto et al. 2005). PmVIII was not encountered in the Atlantic and showed a star shaped pattern suggestive of a recent expansion into the Mediterranean, perhaps from populations along the coasts of West Africa. In contrast, the network of PmV was highly linear and the mismatch distribution showed a multimodal pattern (data not shown). Interestingly, some haplotypes were shared between the Mediterranean, Portugese and Baltic samples (Fig. 9.3) suggesting that PmV expanded from the Mediterranean after the LGM and colonized the Baltic via occasional long-distance dispersal. In this way, the sympatric distribution of PmII and PmV in the Baltic most likely reflects a recent colonisation rather than a long-term stabile sympatry (Wilke & Pfenninger 2002, Peijnenburg et al. 2004). Its presumed absence in the Atlantic may be the result of competition with species already present in the Atlantic. In this scenario, the populations in the Mediterranean would be relict populations.

#### *MACRO-EVOLUTIONARY PROCESSES AFFECTING RADIATION IN AND DISTRIBUTION OF R. (P.) MARINA*

The large amount of cryptic species within *R. (P.) marina* raises questions on whether this radiation happened in sympatry or in allopatry. At first sight, the present study corroborates previous findings on the sympatry of several cryptic species of *R. (P.) marina* (Derycke et al. 2005, 2006). This challenges the alleged niche diversification of nonadaptive radiations (Gittenberger 1991), and allopatric speciation as the most commonly observed speciation mechanism in marine species

(Barraclough & Vogler 2000, Wilke & Pfenninger 2002). There are, however, some elements that may point to allopatric speciation in the *R. (P.) marina* complex. First, the global distribution ranges of the species complex indicate that some lineages are highly dominant in particular biogeographic areas: for example PmI dominates the North Sea, while PmVII is restricted to the English Channel and PmVIII to the Mediterranean Sea. Although this might reflect a sampling artefact, this may also indicate adaptation, competition, or monopolisation preventing or reducing the settlement of closely related species. Secondly, at most three species co-occur at a single locality, and nearly all sympatric occurrences are dominated by a single species (Fig. 9.2). Furthermore, the phylogeny based on COI and two nuclear markers showed that PmI and PmIV are sister taxa, just like PmVI-PmIX and PmII-PmX (Fig 9.1). The most closely related species are generally allopatric, and in the few instances where they do co-occur, the abundance of at least one of these most closely related species is always very low (e.g. in Iceland, Roscoff). A similar pattern has been described in other marine species complexes (Suatoni et al. 2006, Mathews 2006) and in the sea urchin genus *Diadema* (Lessios et al. 2001). In view of the similar habitat in which all species were sampled, the distribution of the species complex most likely reflects competitive exclusion between closely related cryptic species (see also Suatoni et al. 2006). Based on the present data, we have no reason to assume that the species show differences in ecological preferences and we therefore find it unlikely that ecological speciation may be at play.

The effects of the Pleistocene glaciations and long-term geographic isolation are believed to have played a key role in the formation of new species (Avice 1994, Hewitt 2000). Estimating the age of an evolutionary event is often dubious, especially when no reliable fossil records are available. The phylogeographic data in PmII indicate that the last glacial maximum had strong impacts on its population genetic structure. Using this biogeographical evidence, COI divergence rates in *R. (P.) marina* range between 21.7 % and 1.3 % divergence per MY. PmII was highly abundant in the northern samples (Norway, North Scotland and the Baltic), suggesting that its range expansion occurred after the last glacial maximum about 14 ky BP (see also Pinceel et al. 2005). This leads to COI mutation rates that are ten times higher than the generally applied molecular clock of 2 % divergence per MY (Knowlton et al. 2000), which might not be that unrealistic given the small body size and short generation time (down to < 5 days, Vranken & Heip 1983) of *R. (P.) marina* which may enhance

mutation rates (Martin & Palumbi 1993). Furthermore, high direct estimates of mitochondrial base substitution mutation rates have been observed in the close relative *Caenorhabditis elegans* (8.9 per site per MY, Denver et al. 2000). An accelerated molecular clock was also proposed for other nematode species, albeit not to the same extent as in our estimate for *R. (P.) marina* (Nieberding et al. 2005, Blouin et al. 1998). The estimated mutation rate of 21.7 % places the speciation events in the *R. (P.) marina* complex in the middle Pleistocene between 210 and 552 ky BP, and consequently predates the last glacial maximum. Likewise, the closure of the Strait of Gibraltar cannot account for the differences between the Mediterranean and Atlantic species. Rather, the restricted gene flow pattern may be suggestive of allopatric speciation occurring irrespective of climate changes.

## CONCLUSION

The present study nicely illustrates the extent to which the historical signature of the last glacial maximum is detectable in modern population genetic structure. Pleistocene glaciations and restricted gene flow are undoubtedly highly important micro- evolutionary processes affecting the *R. (P.) marina* species. Our results further indicate that the contemporary distribution of the PmII populations in the Southern Bight of the North Sea is the result of at least two postglacial colonisation events and supports the idea of a contact zone around Brittany/Southern Bight of the North Sea. Our study provides clear evidence for restricted gene flow in all lineages, but at the same time indicates that (effective) long distance dispersal may sporadically occur. We hypothesize that the *R. (P.) marina* species complex has an allopatric origin of speciation, and that the current sympatric distribution is the result of Pleistocene contractions/expansions and occasional random effective long distance dispersal. The present study also proves that meiofauna species living on macroalgae can truly be cosmopolitan, and that this broad-scale distribution is the result of occasional long distance dispersal.

PHYLOGEOGRAPHY OF THE *R. (P.) MARINA* COMPLEX

**Appendix 9.1:** Pairwise  $\Phi_{st}$  values for the species PmI, PmII, PmIIIa, PmIV, PmV and PmVIII. Sample abbreviations are as in Table 9.1.

PmI	Sc	Ic	Ni	Os	Bl	Ze	Kr	Pa	Br	Sl
Sc										
Ic	0.23309									
Ni	<b>0.51111</b>	<b>0.56255</b>								
Os	<b>0.54073</b>	<b>0.59121</b>	<b>0.31607</b>							
Bl	<b>0.59013</b>	<b>0.61605</b>	<b>0.35484</b>	<b>0.32250</b>						
Ze	<b>0.43432</b>	<b>0.50314</b>	<b>0.19279</b>	<b>0.16555</b>	0.03143					
Kr	<b>0.48407</b>	<b>0.54598</b>	<b>0.24705</b>	0.03518	0.13631	0.04279				
Pa	<b>0.37151</b>	<b>0.45211</b>	<b>0.13455</b>	<b>0.13566</b>	0.07699	0.00047	0.04557			
Br	<b>0.51747</b>	<b>0.56892</b>	<b>0.26174</b>	<b>0.23815</b>	-0.01090	-0.00039	0.08063	0.03471		
Sl	<b>0.42231</b>	<b>0.49441</b>	<b>0.16500</b>	0.14991	0.04384	-0.01589	0.03717	0.00061	0.00913	

PmII	No	Sc	Ru	Sy	Fle	Ku	Wa	Pl	Ma	Sa	Sl	Bl	GrB	Pa
No														
Sc	0.14034													
Ru	<b>0.60093</b>	<b>0.50811</b>												
Sy	<b>0.65591</b>	<b>0.51649</b>	<b>0.71895</b>											
Fle	<b>0.29255</b>	<b>0.27285</b>	<b>0.45423</b>	<b>0.53760</b>										
Ku	0.08021	0.16369	<b>0.56206</b>	<b>0.61080</b>	<b>0.27478</b>									
Wa	-0.01868	0.16918	<b>0.88763</b>	<b>0.69349</b>	0.24990	0.07132								
Pl	<b>0.16608</b>	0.13270	<b>0.42189</b>	<b>0.43868</b>	<b>0.25761</b>	0.15710	0.14472							
Ma	<b>0.50769</b>	<b>0.41875</b>	<b>0.59124</b>	<b>0.48577</b>	<b>0.50648</b>	<b>0.46527</b>	<b>0.48883</b>	<b>0.20733</b>						
Sa	0.29800	0.19673	<b>0.45667</b>	0.33185	0.31381	0.26404	0.29015	0.12426	<b>0.25379</b>					
Sl	<b>0.81785</b>	<b>0.71510</b>	<b>0.82512</b>	<b>0.72498</b>	<b>0.73240</b>	<b>0.77736</b>	<b>0.82200</b>	<b>0.65785</b>	<b>0.54450</b>	<b>0.60521</b>				
Bl	<b>0.23429</b>	0.14958	<b>0.34290</b>	<b>0.34745</b>	<b>0.29261</b>	<b>0.18393</b>	0.18265	0.04097	0.06409	0.09250	<b>0.46647</b>			
GrB	<b>0.25096</b>	0.18126	<b>0.35954</b>	<b>0.31798</b>	<b>0.30121</b>	<b>0.20949</b>	0.19517	0.04460	0.08706	0.10961	<b>0.53043</b>	0.01420		
Pa	<b>0.41988</b>	<b>0.35548</b>	<b>0.55050</b>	<b>0.47965</b>	<b>0.40529</b>	<b>0.36401</b>	<b>0.39535</b>	0.09634	0.11134	<b>0.20875</b>	<b>0.67009</b>	0.05913	0.01806	

PmIII	Va	Bo	NY	Fl	Ze	Pa	Sl	Os	Bl	Ni	GrB
Va											
Bo	<b>0.54604</b>										
NY	<b>0.32665</b>	0.19372									
Fl	<b>0.41207</b>	0.17330	-0.00670								
Ze	0.24120	<b>0.16508</b>	0.03711	0.02401							
Pa	<b>0.59355</b>	<b>0.27875</b>	<b>0.30626</b>	<b>0.32089</b>	0.14547						
Sl	0.21022	<b>0.23759</b>	0.06803	0.06418	0.00271	0.17912					
Os	<b>0.62435</b>	<b>0.21217</b>	0.28024	<b>0.28225</b>	0.10642	0.10928	0.13786				
Bl	<b>0.41169</b>	0.16019	0.09774	0.08302	-0.00214	0.12351	0.01260	0.01971			
Ni	<b>0.70309</b>	0.04628	0.10619	0.07369	0.07717	0.28000	0.15811	0.20640	0.08977		
GrB	<b>0.40058</b>	<b>0.50313</b>	<b>0.34613</b>	<b>0.39971</b>	<b>0.26215</b>	<b>0.48594</b>	<b>0.23717</b>	<b>0.52160</b>	<b>0.37150</b>	<b>0.54264</b>	

PmIV	GrS	Co	San	GrB
GrS				
Co	0.12162			
San	<b>0.79161</b>	<b>0.91605</b>		
GrB	0.01688	0.24213	<b>0.86344</b>	

PmV	Sy	He	GrL	Ay	Po
Sy					
He	0.27030				
GrL	<b>0.43428</b>	<b>0.47821</b>			
Ay	<b>0.24862</b>	0.24861	<b>0.34461</b>		
Po	0.24970	<b>0.42042</b>	<b>0.47565</b>	<b>0.41130</b>	

PmVIII	KrB	KrM	GrK	Pal
KrB				
KrM	<b>0.30072</b>			
GrK	<b>0.32418</b>	0.17087		
Pal	<b>0.33360</b>	<b>0.18620</b>	<b>0.28349</b>	

118900

---

**CHAPTER X**  
**GENERAL DISCUSSION**

---

In the present thesis, we have focused on the population genetic structure of two free-living marine nematode species complexes. We have investigated the evolutionary processes affecting both species complexes using an experimental and phylogeographic approach, and have used morphological methods to unravel species status of the highly divergent COI lineages. In this last Chapter, we take the opportunity to discuss some **key questions in population genetic and meiofauna studies** in light of our data.

*HOW IMPORTANT ARE BIOLOGICAL CHARACTERISTICS IN DETERMINING THE POPULATION GENETIC STRUCTURE OF MARINE NEMATODES?*

In general, the population genetic structure of marine species is thought to be primarily affected by historical events, geographical barriers and ecological/biological characteristics of the species (Palumbi 1994). Both species (complexes) in our study, *Pellioiditis marina* and *Halomonhystera disjuncta*, were sympatrically distributed on a fairly small geographical scale (< 100 km), suggesting similar effects of history and geography on their population genetic structure. As such, the sympatric distribution of *R. (P.) marina* and *H. disjuncta* gives the opportunity to investigate species-specific effects on their population genetic structure. *H. disjuncta* differs from *R. (P.) marina* in several aspects of its habitat preferences and life-history: while *R. (P.) marina* is nearly completely restricted to macroalgal substrates, *H. disjuncta* also occurs abundantly in the surrounding sediment and on detritus of vascular plant origin (e.g. in marshes). *H. disjuncta* also has a longer generation time than *R. (P.) marina* (more than twice as long under optimal conditions) and does not produce dauerlarvae (See also Introduction Chapter 4). As such, *R. (P.) marina*, like other rhabditids, is an extreme coloniser, whereas *H. disjuncta* is more a general opportunist (Bongers & Bongers 1998). If species-specific effects dominate the population genetic structure in both species, we would expect populations of *R. (P.) marina* to show 1) a higher genetic differentiation and 2) a higher temporal differentiation than populations of *H. disjuncta* due to the higher patchiness of its populations and to its shorter generation time. To investigate this hypothesis, we compared genetic differentiation of the single most abundant species of each species complex (PmI and Gd3) from the small-scale study on the North Sea and adjacent estuaries. We used data from four locations where PmI and Gd3 were sympatric during both the spring and winter sampling. Overall  $\Phi_{st}$  values were very similar among populations of PmI and Gd3 in spring

and winter (Table 10.1). Pairwise  $\Phi_{st}$  values were low and usually not significantly different from zero between populations within the Westerschelde for both species in spring and in winter. The Blankenberge (Bl) population was in most cases differentiated from the Westerschelde populations, but not for Pml during winter (Table 10.1).

A					B				
Overall $\Phi_{st}$ among populations	Gd3		Pml		Gd3	Bl	Br	Pa	Ze
	Spring	Winter	Spring	Winter	Bl	Br	Pa	Ze	
	0.086	0.107	0.101	0.056	Bl		0.17	<b>0.10</b>	<b>0.12</b>
					Br	<b>0.07</b>		<b>0.11</b>	0.01
					Pa	0.01	-0.01		0.03
					Ze	<b>0.19</b>	<b>0.11</b>	0.10	
					Pml				
					Bl		0.06	0.03	-0.01
					Br	<b>0.32</b>		<b>0.15</b>	0.05
					Pa	<b>0.26</b>	0.005		0.03
					Ze	<b>0.31</b>	-0.003	0.009	

**Table 10.1.** A. Overall  $\Phi_{st}$  values (AMOVA) and B. pairwise  $\Phi_{st}$  values based on Tamura & Nei genetic distances between three Westerschelde populations (Br, Pa and Ze) and the coastal Bl location during spring (below diagonal) and winter (above diagonal). Values in bold are significantly different from zero after Bonferroni correction. Sample abbreviations are as in Fig 2.1.

This resulted in higher temporal  $\Phi_{st}$  values in Bl for Pml (0.24) than for Gd3 (0.14), but this pattern was not general (Table 10.2). Both species in our study also showed a similar genetic structure, which fluctuated over time, on a fairly small geographical scale (Chapter 4). The temporal differentiation showed differences between Pml and Gd3, but these did not corroborate our expectations based on life-history characteristics. **The biological and ecological differences between both species were less important for their genetic structure than the effects of highly unstable and fragmented algal patches.** To determine the importance of biological characteristics for the population genetic structure of marine nematodes, a comparison with endobenthic nematode species and/or with species that have highly different life-cycles than that of *R. (P.) marina* and *H. disjuncta* are extremely relevant. The

	Bl	Br	Pa	Ze
Gd3	<b>0.14</b>	0.07	-0.03	<b>0.13</b>
Pml	<b>0.24</b>	<b>0.18</b>	-0.01	0.04

**Table 10.2.** Pairwise  $\Phi_{st}$  values (based on Tamura & Nei genetic distances) between spring and winter populations in each location. Significant values after Bonferroni correction are indicated in bold. Sample abbreviations are as in Fig 2.1.

nematode species (complexes) studied here form an excellent model to describe the effects of patchiness on the population genetic structure.



*HOW TO RECONCILE PRONOUNCED SMALL-SCALE POPULATION GENETIC STRUCTURE WITH A HIGH POTENTIAL FOR GENE FLOW?*

Species living in the intertidal zone of coasts and estuaries are subject to frequent complex alterations in local conditions imposed by the tides. Epiphytic nematodes are regularly suspended in the water column (Alkemade et al. 1994) and may be transported to neighbouring macroalgae. Based on our population genetic data (Chapters 2, 3 and 4) and on the field experiment described in Chapter 7, we can formulate hypotheses on the dynamics of intertidal epiphytic nematode populations and their consequences for the population genetic structure. We found that patches of macroalgae are strongly affected by founder events and priority effects at the within-species level.

**Thus, given that nematodes may become suspended in the water column and transported to neighbouring algae, which patterns in genetic structure can we expect?** The effect of a dispersal propagule on the genetic composition of a nematode population in a macroalgal patch is largely determined by 1) the presence of nematodes on the algae and 2) a combination of favourable abiotic conditions and/or distance to the algae (Fig. 10.1). If the algal patch already contains an established nematode population when a dispersal propagule arrives (case 1), the haplotypes already present will continue to dominate the population through priority effects, and haplotypes of the dispersal propagule will remain only in low frequencies. When a dispersal propagule from a nearby source population arrives in an ‘empty’ habitat patch under abiotic conditions similar to those of that source population (case 2), the developing population will be dominated by haplotypes of the founder propagule. In general, empty patches in the proximity of a source population will, upon colonisation, genetically resemble that source population. If, however, an empty patch is more distant from the source population or, alternatively, if it experiences sufficient abiotic stress to cause substantial mortality in any founding propagule (case 3), founder effects will be accompanied by genetic bottlenecks thereby reducing genetic diversity. If such a patch already contained nematodes, then haplotypes of the newly arriving propagule will remain very rare. In all cases, the genetic make-up at this short time scale is determined by priority effects of the nematodes that first colonised a

patch and can cause high genetic differences between populations/ algal patches (compare end situation of the three cases in Fig 10.1A).

On a longer time scale, the genetic composition of nematode populations on algae will randomly fluctuate depending on which nematodes become suspended and settle. As such, sampling an intertidal epiphytic population in different seasons will in most cases lead to a different genetic composition (compare Fig 10.1A with 10.1B). In Chapter 3, we have shown that the genetic composition of *R. (P.) marina* on permanent *Fucus* stands also fluctuates over time, and consequently, the processes described above may be characteristic of intertidal phytal habitats rather than solely for decomposing patches. Incubation of fragments from living *Fucus* stands in the lab occasionally yielded no nematodes and suggests that living *Fucus* stands may have empty parts. This observation strengthens our hypothesis on the generality of the colonisation processes for phytal habitats.

The above processes explain how a genetic structuring can be observed on a small geographical scale despite a high potential for gene flow. This clearly illustrates **the need for temporal surveys of population genetic structure on small geographical scales, especially in species with highly dynamic populations.**

Next to colonisation dynamics, a pronounced genetic structure despite high gene flow may also arise from unfavourable conditions at certain locations. In Chapter 8 we have shown that suboptimal conditions and sublethal concentrations of toxic substances may hamper population development, which may cause a genetic bottleneck. Alternatively, the effects of genetic drift may alter the genetic composition of the population (Van Straalen & Timmermans 2002). We were unable to detect persistent significant changes in the mitochondrial genetic composition of the developing *R. (P.) marina* populations, but this may have been due to the short time scale of the experiment.

**Fig 10.1** Factors affecting the genetic composition of nematode populations on algae. Case 1: a dispersal propagule arrives in a habitat already occupied by the same nematode species (indicated by blue coloured nematodes); Case 2: the dispersal propagule originates from a nearby source population and arrives in an empty habitat patch under favourable conditions; Case 3: as in Case 2, BUT the distance between source population and colonised habitat patch is large and/or the newly colonised patch experiences unfavourable conditions. A: two dispersal propagules are illustrated associated with high tide during one tidal cycle; B: time scale of several weeks to months. Differently coloured nematodes indicate different haplotypes.

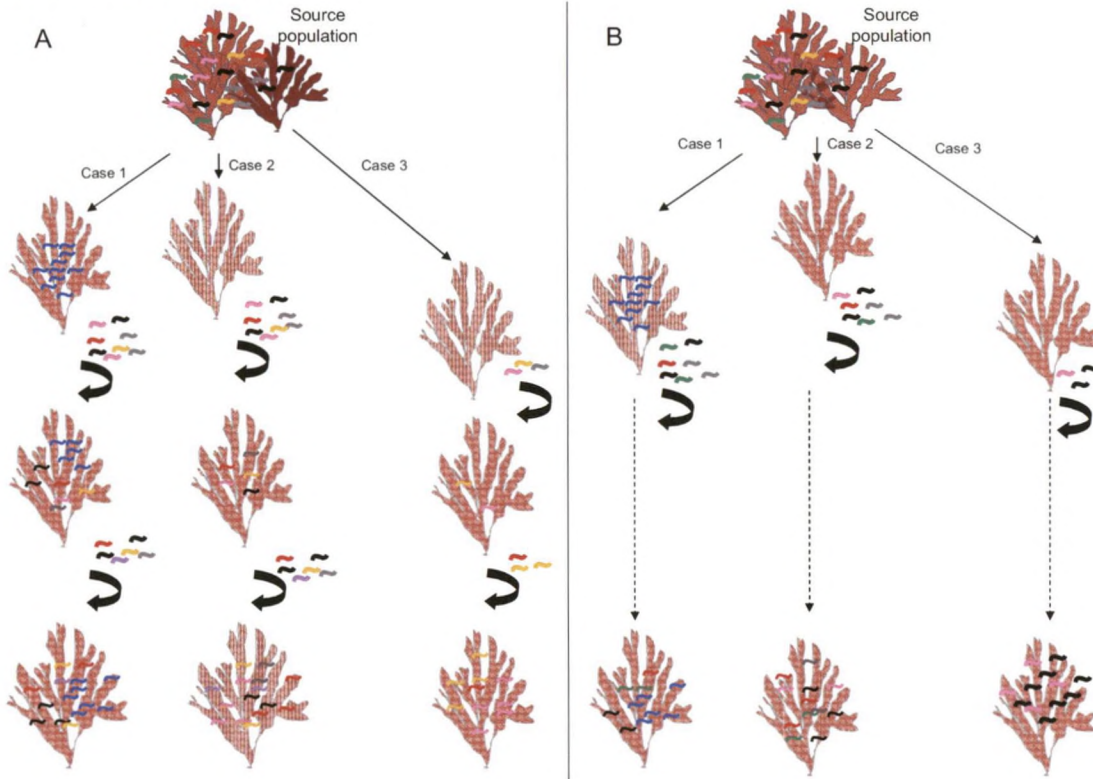

*HOW CAN HIGHLY SIMILAR SPECIES COEXIST?*

Our findings at the population level may well be extrapolated to the species level. In Chapter 9, we documented the sympatric distribution of member species of the *R. (P.) marina* species complex on a worldwide scale. The differential distribution of sister taxa has been related to temperature (Schroth et al. 2002), pollution (Schizas et al. 2001), behavioral mechanisms (Caudill & Bucklin 2004) or different ecological preferences (Rundle et al. 2000, Dawson et al. 2002). Our seasonal genetic survey showed clear fluctuations in the abundances of cryptic species on a local scale (Chapters 3 and 4), which might reflect different temperature preferences or tolerances. In addition, the controlled experiment in Chapter 8 suggested that PmII may prefer marine salinities, which was in agreement with its distribution along the Belgian coast and adjacent estuaries: PmII was never encountered at salinities below 25. However, the global distribution of PmII clearly showed that it lives under a variety of salinities and temperature regimes, as it is present from the Baltic Sea to the Bay of Biscay. Furthermore, we found co-occurring (cryptic) species on the same algal patch, implying that ecological differences, if any, are situated at microscales. In a highly unstable and fluctuating intertidal environment, we consider such micro-allopatry highly unlikely. **How then can several morphologically similar species co-occur in the same habitat?** For highly diverse plankton communities, the coexistence of many species on a handful of resources can be explained by resource competition generating oscillations and chaos in species abundances (Huisman & Wiessing 1999). Moreover, models have indicated that even in homogeneous and constant environments plankton communities will never settle to equilibrium (reviewed in Scheffer et al. 2003). For our nematode communities on macroalgal deposits, we propose a mechanism that is largely dominated by random events ('chaos') and that is essentially very similar to the mechanism described in Fig 10.1. Epiphytic nematode communities living in intertidal environments are regularly subject to suspension in the water column (Fegley 1987, Alkemade et al. 1994) and may raft on macroalgae. Such dispersal is intrinsically random, and when a cryptic species is eventually washed ashore onto an empty habitat patch, population establishment is likely to be successful, provided environmental conditions are favourable. If, however, another cryptic species is already present, competitive

exclusion may occur (see also Suatoni et al. 2006). In this respect, the observation that the most closely related cryptic species co-occur only sporadically (Chapter 9) may indicate that only very recent species in the species complex compete for the same resources, while genetically more diverged species avoid competitive exclusion, perhaps through resource partitioning. There is evidence for resource partitioning among closely related genera and even among congeneric bacterivorous nematodes on decomposing organic material (De Mesel et al. 2004), but whether this may also occur among cryptic species remains to be investigated. Both species complexes studied in this thesis form, however, excellent models to test the above hypothesis of resource use as *R. (P.) marina* and *H. disjuncta* are easily isolated and culturable in the lab. Alternatively, the species present on the algae may monopolise resources, thus hampering population development of newly arriving species (De Meester et al. 2002). Both hypotheses, competitive exclusion and monopolisation of resources, imply that resources are limiting, which is difficult to assess in such highly dynamic systems (although *R. (P.) marina* requires very high bacterial densities, Moens & Vincx 1996). In the absence of ecological and biological data of the cryptic species, their coexistence remains highly speculative.

#### WHAT EVIDENCE DO WE HAVE FOR DISPERSAL CAPACITIES IN MARINE NEMATODES?

The term ‘meiofauna paradox’ commonly refers to the distribution of small invertebrate species lacking pelagic stages in widely separated marine areas around the world (Giere 1993). Molecular tools have demonstrated that many cosmopolitan distributions in fact represent different cryptic species (e.g. Todaro et al. 1996, Schmidt & Westheide 1999). Prior to this study, no such data were available for free-living nematodes. In particular, there is little direct evidence for the transport of nematodes over large oceanic distances and little is known about their passive dispersal (Coomans 2002). *R. (P.) marina* and *H. disjuncta* have a cosmopolitan distribution (see the cited literature in Chapter 4 for *H. disjuncta*, and Chapter 2 for *R. (P.) marina*) which may not be that surprising given their epiphytic habitat preference. Indeed, several nematode genera have been observed on drifting macroalgae (Thiel & Gutow 2005), and we were able to isolate four *R. (P.) marina* specimens from a patch of drifting algae in the North Sea. **So, do epiphytic nematodes effectively disperse over large distances?** The phylogeographic survey presented in Chapter 9 showed

that the recent genetic patterns were the result of isolation by distance (see Table 9.5), suggesting that populations of the most widely distributed species, PmII, are structured by dispersal limitations. There were, however, also some indications for long distance dispersal (see discussion Chapter 9). In addition, geographically distant populations sometimes share similar haplotypes, but in low frequency. **Yes, epiphytic nematodes thus can raft over large distances, but successful population establishment only occurs sporadically.** If long distance dispersal would be a common phenomenon for epiphytic nematodes, we would not have been able to detect the historical patterns of genetic structure (see Chapter 9), because they would have been faded by contemporary gene flow. **At what geographical scales does dispersal than occur?** In Chapter 7, we found evidence for a rapid colonisation of empty algal patches, which implies that **passive dispersal at scales of hundreds of meters is substantial.** In Chapters 2, 3 and 4, we found a significant genetic structuring among populations of many cryptic lineages at small spatial scales along the Belgian coast and the estuaries in the southwestern part of The Netherlands. Based on the comparison between PmI and Gd3 in the first part of this Chapter, we now know that the differences in genetic composition at these relatively small geographic distances are dominated by temporal fluctuations. In combination with the high amount of shared haplotypes and the presence of only few unique haplotypes among populations in the Belgian and Dutch locations, we conclude that **epiphytic nematodes are able to disperse at scales of several tens of km.** At larger geographical scales, dispersal may be a function of water currents, local retention of nematodes in the water column or active migration from the water column to suitable substrates (Palumbi 1994, Cowen et al. 2006, Ullberg & Olafsson 2003). Although endobenthic nematodes can be suspended in the watercolumn (Fegley 1987), a population genetic study in a truly endobenthic nematode species is required to infer the generality of these results for marine nematode species.

#### *IS DNA-BARCODING THE SOLUTION FOR NEMATODE IDENTIFICATION?*

In Chapters 5 and 6, we described and illustrated the problems that classical nematode taxonomy is facing today: the limited number of diagnostic morphological characters and the -increasingly rare- expertise required for a correct distinction between population variability and species diagnosis result in a huge taxonomic

deficit of the phylum (Coomans 2002, Blaxter et al. 2005). A **DNA-barcoding approach** may be a solution to enhance biodiversity studies in nematodes (Blaxter 2004, Bhadury et al. 2006). In essence, such a system seeks to provide rapid, accurate and automatable species identification by using short, standardized gene regions as internal species tags (Hebert & Gregory 2005). The mitochondrial COI gene in particular has certain features rendering it a potentially very useful marker for this purpose (Hebert et al. 2003 a,b). The barcoding concept has initiated a very lively debate between classical taxonomists and advocates of the barcoding system (Smith 2005, Hebert & Gregory 2005, Will et al. 2005).

**Why is DNA barcoding so problematic for classical taxonomists?**

Taxonomy is far more than the identification of species and the major concern of taxonomists is that naming new species and studying their relationships will be based on a single marker system which evidently goes back to the typological species concept (Will et al. 2005). Moreover, no information on the biology of the specimens and on evolutionary processes generating new species will be obtained by using such an approach. Molecular taxonomists currently tend to show a lack of interest in morphological vouchering and descriptions of the taxonomic units they detect (Will et al. 2005).

**Does this imply that DNA-barcoding is pointless?** Despite the above criticisms, DNA-barcoding has evident advantages. A barcoding system can rapidly identify known species with difficult morphology, and even juveniles or eggs can be correctly identified. It does not require taxonomic expertise and is therefore applicable for a general audience, provided that the necessary DNA amplification facilities are available. The principle goal is thus to identify known species. However, at the early stages of promoting the technique, it was suggested that barcoding may also aid in the discovery of new species (Hebert et al 2003a), and it is exactly there that lays its main weakness: when are sequences divergent enough to discern species? To answer this question, **sufficient data on intra- and interspecific variation of the COI (or another) gene in a wide variety of species are required**, and even then a general rule will most likely fail to delineate all species on Earth. Species evolve as a result of many processes, the outcome of which being unpredictable.

	PmI	PmII	PmIII	PmIV	PmV	PmVI	PmVII	PmVIII	PmIX	Gd1	Gd2	Gd3	Gd4	Gd5
PmI	0.0096													
PmII	0.0878	0.0097												
PmIII	0.079	0.0889	0.0166											
PmIV	0.0663	0.0791	0.0699	0.0104										
PmV	0.0988	0.0914	0.0869	0.0895	0.0263									
PmVI	0.1009	0.0698	0.0721	0.0814	0.0853	0.0116								
PmVII	0.0976	0.0827	0.0868	0.1067	0.0979	0.0743	0.0151							
PmVIII	0.0965	0.0762	0.0735	0.0907	0.0974	0.0793	0.0808	0.0135						
PmIX	0.096	0.0736	0.0763	0.0832	0.0836	0.044	0.0804	0.079	0.0045					
Gd1	0.2956	0.2868	0.3107	0.2957	0.2942	0.2946	0.3058	0.3005	0.2949	0.0156				
Gd2	0.2741	0.2615	0.2822	0.2815	0.2709	0.2693	0.2954	0.2721	0.2661	0.1923	0.0125			
Gd3	0.3346	0.338	0.3488	0.3442	0.3496	0.3374	0.3612	0.3398	0.3465	0.2436	0.2198	0.0121		
Gd4	0.3041	0.3091	0.2989	0.3092	0.3148	0.3051	0.3326	0.3129	0.3048	0.1812	0.2371	0.2364	0.0437	
Gd5	0.3066	0.3128	0.3248	0.3086	0.3149	0.3172	0.327	0.3187	0.3274	0.2281	0.1487	0.2481	0.2382	0.02

**Table 10.3:** P- distances based on the COI gene for the cryptic taxa found within *R. (P.) marina* and *H. disjuncta* (PmX and Z3 are omitted because of the limited number of haplotypes found). Diagonal: within-species divergence; below diagonal: average between-species divergence.

Hebert & Gregory (2005) have arbitrarily set the threshold for assigning new species at a sequence divergence that is 10 times the average within-species variation. Our data from *R. (P.) marina* and *H. disjuncta* corroborate the idea that intraspecific COI divergences generally are not higher than 2 % (Avice 2000), while congeneric values are higher than 8 % (Hebert et al. 2003b) (Table 10.3). Our congeneric values substantially differ, however, between those of the *R. (P.) marina* species (8.4 % on average) and those of the *H. disjuncta* species (average of 21.7 %) illustrating the difficulty in assigning species status solely on the basis of sequence divergence. In the case of *R. (P.) marina*, not a single cryptic species, and not even the closely related species *Rhabditis nidrosiensis* and *R. (P.) mediterranea*, would have been detected using the 10 times rule. **No single molecular or morphological method can be used for species identification without proper knowledge of the extant diversity and variability in this, and any other, phylum.**

For identification of highly problematic meiofauna taxa, like nematodes, an evolutionary framework based on DNA-sequences (DNA-based taxonomy) may be much more valuable than classical morphological taxonomy (Adams 1998, 2001, Nadler 2002). Here, DNA-sequences, and not morphological characters, are used as identification tag, and additional information from other character systems (morphology, ecology, taxonomy) is added to the database. As such, the sequence serves as a standard for future reference, together with the type specimen and DNA-preparation (Tautz et al. 2003). Efficient vouchering systems are now available to provide not only sequences but also detailed morphological images of any nematode specimen (De Ley & Bert 2002, De Ley et al. 2005).

This thesis has illustrated the power of COI to identify new nematode species, but more importantly, it supports the contention that **more than one genomic region**



**is required for a correct delineation of new species.** A DNA-barcode based on at least two independent markers may indeed pinpoint species which would not have been detected by classical taxonomy nor by current DNA-barcoding ‘rules’, and is able to distinguish known species. **DNA-barcoding is therefore a helpful tool to explore and screen biological diversity** for taxa which form a true morphological challenge. As such, newly discovered molecular lineages can then be further investigated morphologically, biologically and ecologically. Only in this way can a solid framework arise against which species status can be tested (De Ley et al. 2005, Smith 2005, Chapter 5). Such **an integrative taxonomy approach may reconcile classical taxonomists and DNA-barcoders** (Smith 2005). Evidently this would be at the expense of rapid identification. As long as we do not have sufficient molecular data in a variety of species, a rapid AND adequate identification system based on a short stretch of DNA remains a utopia and handheld barcoding devices better stay in the trustworthy hands of captain Jean-Luc Picard...

#### SUGGESTIONS FOR FUTURE RESEARCH

This study has generated some interesting perspectives for future population genetic studies in marine nematodes. We focused on nematode species living on macroalgae to obtain a clear picture on the genetic structure of nematode species in highly dynamic and patchily distributed habitats. It would now be interesting to perform **a population genetic survey in benthic nematodes from different marine habitats** to investigate whether their dispersal capacity and population genetic structure is similar to that of nematodes on macroalgae. Including species with a considerably longer generation time and lower reproductive capacity would be particularly interesting to unravel effects related to the biological characteristics of species. Investigating marine nematode species with different ecology and biology would yield important information on the generality of our results for the phylum Nematoda.

Although our study was not designed to investigate the differential effects of coasts, estuaries and lakes, we found a stronger differentiation between *R. (P.) marina* populations from different habitat types than between population from a similar habitat, suggesting that habitat characteristics may influence the genetic structure of *R. (P.) marina* (Chapter 3). The effects of dynamic, tide dominated habitats on the population genetic structure could be compared with those of more stable

environments by **investigating the genetic structure in other estuaries and lakes at the same latitude**. At the same time, **the application of microsatellite markers** may unravel more subtle population genetic differences within estuaries and may give an even clearer picture on the small-scale dispersal capacity of nematodes.

The biological and ecological characteristics and preferences of the observed cryptic taxa are at this point unknown. It is therefore advisable to perform **controlled experiments to obtain information on the resource partitioning and abiotic preferences/tolerances of the cryptic species**. This could also yield information on the speciation modes leading to the cryptic radiations, and on local adaptation, which may be particularly relevant for understanding priority effects and monopolisation of resources.

The coexistence of similar species within the same trophic group can be explained by niche segregation and/or stochastic factors. If controlled experiments would indicate that niches of different cryptic species overlap substantially, then the species complexes would form an excellent model **to investigate the importance of stochastic factors in the coexistence of species**. This could be investigated through laboratory experiments in which colonisation of *Fucus* thalli is followed under different scenarios with and without stochastic environmental fluctuations causing mortality.

We currently know little about the relationship between genetic variation and resilience of species to environmental disturbances. In chapter 8, we described the effects of sublethal stressors on the population development and genetic diversity of *R. (P.) marina*. Although we followed the genetic variation up to the fifth generation, it would be interesting **to develop a strategy to monitor the effects of sublethal stressors during a longer period**. Likewise, the effects of abiotic stressors on populations with different degrees of genetic variation would yield important insights on their **resilience to disturbance**. Such a relationship may be investigated, for example, by following the colonisation success of detritus under different types of stress (predation, sublethal temperatures, physical disturbance, ...) in function of the genotypic diversity of a source population. These fine-scale patterns may be better detected with microsatellite markers than with mitochondrial haplotype data, as microsatellite markers are distributed on several loci and also yield information on the heterozygosity of alleles. As such, a larger part of the genome is screened and more subtle patterns can be observed.

---

## CITED LITERATURE

---

## CITED LITERATURE

---

- Aars J, Dallas F, Piertney B, Marshall F, Glow J., Telfer S, Lambin X (2006) Widespread gene flow and high genetic variability in populations of water voles *Arvicola terrestris* in patchy habitats. *Mol Ecol* 15: 1455-1466.
- Abebe E, Blaxter M (2003) Comparison of biological, molecular and morphological methods of species identification in a set of cultured *Panagrolaimus* isolates. *J Nematol* 35: 119-128.
- Adams BJ (1998) Species concepts and the evolutionary paradigm in modern nematology. *J Nematol* 30: 1-21.
- Adams BJ (2001) The species delimitation uncertainty principle. *J Nematol* 33: 153-160.
- Agudelo P, Robbins RT, Stewart JM, Szalanski AL (2005) Intraspecific variability of *Rotylenchulus reniformes* from cotton-growing regions in the United States. *J Nematol* 37: 105-114.
- Alkemade R, Wielemaker A, Hemminga MA (1992) Stimulation of *Spartina anglica* leaves by the bacterivorous marine nematode *Diplolaimelloides brucei*. *J Exp Mar Biol Ecol* 159: 267-278.
- Ali A, Al-Ogaily SM, Al-Asgah NA, Gropp J (2003) Effect of sublethal concentrations of copper on the growth performance of *Oreochromis niloticus*. *J Appl Ichthyol* 19: 183-188.
- Alkemade R, Wielemaker A, Herman P, Hemminga M (1994) Population dynamics of *Diplolaimelloides brucei*, a nematode associated with the salt marsh plant *Spartina anglica*. *Mar Ecol Progr Ser* 105: 277-284.
- Aller RC, Aller JY (1992) Meiofauna and solute transport in marine muds. *Limnol Oceanogr* 37: 1018-1033.
- Amato A, Kooistra WHCF, Ghiron JHL, Mann DG, Pröschold T, Montresor M (2006) Reproductive isolation among sympatric cryptic species in marine diatoms. *Protist*: doi:10.1016/j.protis.2006.10.001
- Anderson RV, Gould WD, Woods LE, Cambardella C, Ingham RE, Coleman DC (1983) Organic and inorganic nitrogenous losses by microbivorous nematodes in soil. *Oikos* 40: 75-80.
- Anderson FE, Swofford DL (2004) Should we be worried about long-branch attraction in real data sets? Investigations using metazoan 18S rDNA. *Mol Phyl Evol* 33: 440 – 451.

- Andrássy I (1981) Revision of the order Monhysterida (Nematoda) inhabiting soil and inland waters. *Opus Zool* 17-18: 13-47.
- Andrássy I (1983) A taxonomic review of the suborder Rhabditina (Nematoda: Secernentea). Paris: Office de la Recherche Scientifique et Technique Outre-Mer.
- Andrássy I (1984) Klasse Nematoda (Ordnungen Monhysterida, Desmoscolecida, Araeolaimida, Chromadorida, Rhabditida). Academie-Verlag, Berlin, Germany.
- Andrássy I (2006) *Halomonhystera*, a new genus distinct from *Geomonhystera* Andrássy, 1981 (Nematoda : Monhysteridae). *Meiofauna Marina* 15 : 11-24.
- Arbogast BS, Edwards SV, Wakeley J, Beerli P, Slowinski JB (2002) Estimating divergence times from molecular data on phylogenetic and population genetic timescales. *Annu Rev Ecol Syst* 33:707-740.
- Arnaud JF, Laval G (2004) Stability of genetic structure and effective population size inferred from temporal changes of microsatellite DNA polymorphisms in the land snail *Helix aspersa* (Gastropoda: Helicidae). *Biol J Linn Soc* 83: 89-102.
- Arunachalam S, Jeyalakshmi K, Aboobucker S (1980) Toxic and sublethal effects of carbaryl on a freshwater catfish, *Mystus vittatus* (Bloch). *Arch Environ Contam Toxicol* 9: 307-316.
- Asmussen MA, Arnold J, Avise JC (1987) Definition and properties of disequilibrium statistics for associations between nuclear and cytoplasmic genotypes. *Genetics* 115: 755-768.
- Avise JC (1992) Molecular population structure and the biogeographic history of a regional fauna- a case-history with lessons for conservation biology. *Oikos* 63: 63-76.
- Avise JC (1995) Mitochondrial DNA polymorphism and a connection between genetics and demography of relevance to conservation. *Conserv Biol* 9: 686-690.
- Avise JC (2000) *Phylogeography: the history and formation of species*. Harvard University Press, Cambridge.
- Avise JC, Arnold J, Ball RM, Bermingham E, Lamb T, Neigel JE, Reeb CA, Saunders NC (1987) Intraspecific phylogeography: the mitochondrial DNA bridge between population genetics and systematics. *Annu Rev Ecol Syst* 18: 489-522.
- Avise JC, Walker D (1999) Species realities and numbers in sexual vertebrates: perspectives from an asexually transmitted genome. *Proc Natl Acad Sci USA* 96: 992-995.

## CITED LITERATURE

---

- Baeyens WFJ, van Eck B, Lambert C, Wollast R, Goeyens L (1998) General description of the Scheldt estuary. *Hydrobiologia* 366: 1-14.
- Baker AM, Bartlett C, Bunn SE, Goudkamp K, Sheldon F, Hughes JM (2003) Cryptic species and morphological plasticity in long-lived bivalves (Unionoida: Hyriidae) from inland Australia. *Mol Ecol* 12: 2707-2717.
- Bakker J, Bouwman-Smits L (1988) Contrasting rates of protein and morphological evolution in cyst nematode species. *Phytopathology* 78: 900-904.
- Ballard JW, Rand DM (2005) The population biology of mitochondrial DNA and its phylogenetic implications. *Annu Rev Ecol Syst* 36: 621-642.
- Barber PH, Palumbi SR, Erdmann MV, Moosa MK (2000) A marine Wallace's line; *Nature* 406: 692-693.
- Barber PH, Palumbi SR, Erdmann MV, Moosa MK (2002) Sharp genetic breaks among populations of *Haptoquilla pulchella* (Stomatopoda) indicate limits to larval transport: patterns, causes, and consequences. *Mol Ecol* 11: 659-674.
- Barcia AR, López GE, Hernández D, García-Machado E (2005) Temporal variation of the population structure and genetic diversity of *Farfantepenaeus notialis* assessed by allozyme loci. *Mol Ecol* 14: 2933-2942.
- Barraclough TG, Vogler AP (2000) Detecting the geographical pattern of speciation from species-level phylogenies. *Am Nat* 155: 419-434.
- Bekkevold D, André C, Dahlgren TG, Clausen LAW, Torstensen A, Mosegaard H, Carvalho GR, Christensen TB, Norlinder E, Ruzzante DE (2005) Environmental correlates of population differentiation in Atlantic herring. *Evolution* 59: 2656-2668.
- Belfiore NM, Anderson SL (2001) Effects of contaminants on genetic patterns in aquatic organisms: a review. *Mutat Res* 489: 97-122.
- Bernatchez L, Wilson CC (1998) Comparative phylogeography of nearctic and palearctic fishes. *Mol Ecol* 7: 431-452.
- Beszteri B, Acs E, Medlin LK (2005) Ribosomal DNA sequence variation among sympatric strains of the *Cyclotella meneghiniana* complex (Bacillariophyceae) reveals cryptic diversity. *Protist* 156: 317-333.
- Bhadury P, Austen MC, Bilton DT, Lambshead PJD, Rogers AD, Smerdon GR (2006) Development and evaluation of a DNA-barcoding approach for the rapid identification of nematodes. *Mar Ecol Progr Ser* 320: 1-9.

- Bickham JW, Sandhu S, Hebert PDN, Chikhi L, Athwal R (2000). Effects of chemical contaminants on genetic diversity in natural populations: implications for biomonitoring and ecotoxicology. *Mutat Res* 463: 33-51.
- Bilton DT, Paula J, Bishop JDD (2002) Dispersal, genetic differentiation and speciation in estuarine organisms. *Est Coast Shelf Sci* 55: 937-952.
- Blaxter M (2004) The promise of a DNA taxonomy. *Philos Trans R Soc Lond B* 359: 669-679.
- Blaxter ML, De Ley P, Garey JR, Liu LX, Scheldeman P, Vierstraet A, Vanfleteren JR, Mackey LY, Dorris M, Frisse LM, Vida JT, Thomas WK (1998) A molecular evolutionary framework for the phylum Nematoda. *Nature* 392: 71-75.
- Blaxter M, Floyd R (2003) Molecular taxonomics for biodiversity surveys: already a reality. *Trends Ecol Evol* 18: 268-269.
- Blaxter M, Mann J, Chapman T, Thomas F, Whitton C, Floyd R, Abebe E (2005) Defining operational taxonomic units using DNA barcode data. *Philos Trans R Soc Lond B* 360: 1935-1943.
- Blouin MS (2002) Molecular prospecting for cryptic species of nematodes: mitochondrial DNA versus internal transcribed spacer. *Int J Parasitol* 32: 527-531.
- Blouin MS, Yowell CA, Courtney CH, Dame JB (1995) Host-movement and the genetic structure of populations of parasitic nematodes. *Genetics* 141: 1007-1014.
- Blouin MS, Yowell CA, Courtney CH, Dame JB (1997) *Haemonchus placei* and *Haemonchus contortus* are distinct species based on mitochondrial DNA evidence. *International J Parasitol* 27: 1383-1387.
- Blouin MS, Yowell CA, Courtney CH, Dame JB (1998) Substitution bias, rapid saturation, and the use of mtDNA for nematode systematics. *Mol Biol Evol* 15: 1719-1727.
- Blust R, Kockelbergh E, Baillieul M (1992). Effect of salinity on the uptake of cadmium by the brine shrimp *Artemia franciscana*. *Mar Ecol Prog Ser* 84: 245-254.
- Bohonak AJ (2002) IBD (Isolation By Distance): a program for analyses of isolation by distance. *J Hered* 93: 153-154.
- Boileau M, Hebert P, Schwartz S (1992) Non-equilibrium gene frequency divergence: persistent founder effects in natural populations. *J Evol Biol* 5: 25-39.

## CITED LITERATURE

---

- Bond JE, Sierwald P (2002) Cryptic speciation in the *Adenobolus excisus* millipede species complex on the island of Jamaica. *Evolution* 56: 1123-1135.
- Bongers T, Bongers M (1998) Functional diversity of nematodes. *Appl Soil Ecol* 10: 239-251.
- Boucher G, Lamshead PJD (1995) Ecological biodiversity of marine nematodes in samples from temperate, tropical, and deep sea regions. *Conserv Biol* 9: 1594-1604.
- Bousset L, Henry PY, Sourrouille P, Jarne P (2004) Population biology of the invasive freshwater snail *Physa acuta* approached through genetic markers, ecological characterisation and demography. *Mol Ecol* 13: 2023-2036.
- Bouwman L, Romeyn K, Kremer D, van Es F (1984) Occurrence and feeding biology of some nematode species in estuarine aufwuchscommunities. *Cah Biol Mar*: 287-303.
- Brendonck L, De Meester L, Riddoch B (2000) Regional structuring of genetic variation in short-lived rock pool populations of *Brachipodopsis wolffi* (Crustacea: Anostraca). *Oecologia* 123: 506-515.
- Buckley JT, Roch M, McCarter JA, Rendell CA, Matheson AT (1982) Chronic exposure of Coho salmon to sublethal concentrations of copper. 1. Effect on growth, on accumulation and distribution of copper, and on copper tolerance. *Comp Biochem Physiol C*.
- Bruna EM, Fisher RN, Case TJ (1996) Morphological and genetic evolution appear decoupled in Pacific skinks (Squamata: Scincidae: Emoia). *Proc R Soc Lond B* 263: 681-688.
- Bull JJ, Huelsenbeck JP, Cunningham CW, Swofford DL, Waddell PJ (1993) Partitioning and combining data in phylogenetic analysis. *Syst Biol* 42: 384-397.
- Butler MH, Wall SM, Luehrsen KR, Fox GE, Hecht RM (1981) Molecular relationships between closely related strains and species of nematodes. *J Mol Evol* 18: 18-23.
- Caley MJ, Carr MH, Hixon MA, Hughes TP, Jones GP, Menge BA (1996) Recruitment and the local dynamics of open marine populations. *Annu Rev Ecol Syst* 27: 477-500.
- Camus PA, Lima M (2002) Populations, metapopulations, and the open-closed dilemma: the conflict between operational and natural population concepts. *Oikos* 97: 433-438.



- Carneiro RMDG, Castagnone – Sereno P, Dickson DW (1998) Variability among four populations of *Meloidogyne javanica* from Brazil. *Fund Appl Nematol* 21: 319-326.
- Caudill CC, Bucklin A (2004) Molecular phylogeography and evolutionary history of the estuarine copepod, *Acartia tonsa*, on the Northwest Atlantic coast. *Hydrobiologia* 511: 91-102.
- Cavalli-Sforza LL, Edwards AWF (1967) Phylogenetic analysis: models and estimation procedures. *Evolution* 21: 550-570.
- Charbonnel N, Quesnoit M, Razatavonjizay R, Brémond P, Jarne P (2002) A spatial and temporal approach to microevolutionary forces affecting population biology in the freshwater snail *Biomphalaria pfeifferi*. *Am Nat* 160: 741-755.
- Chitwood BG, Murphy DG (1964) Observations on two marine Monhysterids - their classification, cultivation, and behaviour. *Trans Am Microsc Soc* 83: 311-329.
- Clarke KR (1993) Non – parametric multivariate analyses of changes in community structure. *Austr J Ecol* 18: 117-143.
- Clarke KR, Warwick RM (1994) Change in marine communities: an approach to statistical analysis and interpretation. Plymouth Marine Laboratory, United Kingdom.
- Clarke KR, Gorley RN (2001) Primer v5: User manual/tutorial. Primer-E Ltd., Plymouth.
- Clement M, Posada D, Crandall KA (2000) TCE: a computer program to estimate gene genealogies. *Mol Ecol* 9: 1657-1659.
- Cognato AI (2006) Standard percent DNA sequence difference for insects does not predict species boundaries. *J Econ Entomol* 99: 1037-1045.
- Cognetti G, Maltagliati F (2004) Strategies of genetic biodiversity conservation in the marine environment. *Mar Pollut Bull* 48: 811-812.
- Colombini I, Chelazzi L (2003) Influence of marine allochthonous input on sandy beach communities. *Oceanogr Mar Biol Annu Rev* 41:115-159.
- Coomans A (1979) General principles of systematics with particular reference to speciation. In: Lamberti, F, Taylor CE, eds. *Root-knot nematodes Meloidogyne* species: systematics, biology, and control. New York: Academic Press, 1-19.
- Coomans A (2000) Nematode systematics: past, present and future. *Nematology* 2: 3-7.

## CITED LITERATURE

---

- Coomans A (2002) Present status and future of nematode systematics. *Nematology* 4: 573-582.
- Coull BC (1999) Role of meiofauna in estuarine soft-bottom habitats. *Austral J Ecol* 24: 327-343.
- Cowen RK, Paris CB, Srinivasan A (2006) Scaling of connectivity in marine populations. *Science* 311: 522-527.
- Cowen RK, Lwiza KMM, Sponaugle SU, Paris CB, Olson DB (2000) Connectivity of marine populations: open or closed? *Science* 287: 857-859.
- Coyer JA, Peters AF, Stam WT, Olsen JL (2003) Post-ice age colonisation and differentiation of *Fucus serratus* L. (Phaeophyceae; Fucaceae) populations in Northern Europe. *Mol Ecol* 12: 1817-1829.
- Crandall KA, Templeton AR (1993) Empirical tests of some predictions from coalescent theory with applications to intraspecific phylogeny reconstruction. *Genetics* 134: 959-969.
- Crandall KA, Bininda-Emonds ORP, Mace GM, Wayne RK (2000) Considering evolutionary processes in conservation biology. *Trends Ecol Evol* 15: 290-295.
- Cullen DJ (1973) Bioturbation of superficial marine sediments by interstitial meiobenthos. *Nature* 242: 323-324.
- Dahl U, Gorokhova E, Breitholz M (2006) Application of growth-related sublethal endpoints in ecotoxicological assessments using a harpacticoid copepod. *Aquat Toxicol* 77: 433-438.
- Darling KF, Kucera M, Pudsey CJ, Wade CM (2004) Molecular evidence links cryptic diversification in polar planktonic protists to Quaternary climate dynamics. *PNAS* 101: 7657-7662.
- Dawson AG (1992) *Ice age Earth: late Quaternary geology and climate*. Routledge Press, London.
- Dawson MN, Louie KD, Barlow M, Jacobs DK, Swift CC (2002) Comparative phylogeography of sympatric sister species, *Clevelandia ios* and *Eucyclogobius newberryi* (Teleostei, Gobiidae), across the California Transition Zone. *Mol Ecol* 11: 1065-1075.
- Dayrat B (2005) Towards integrative taxonomy. *Biol J Lin Soc* 85: 407-415.
- De Coninck LA, Schuurmans Stekhoven JH (1933) The free-living marine nematodes of the Belgian coast II. *Mém Mus R Hist Nat Belg* 58: 1- 163.

- De Gruijter JM, Polderman Am, Zhu XQ, Gasser RB (2002) Screening for haplotypic variability within *Oesophagostomum bifurcum* (Nematoda) employing a single-strand conformation polymorphism approach. *Mol Cell Prob* 16: 185-190.
- De Ley P (2000) Lost in worm space: phylogeny and morphology as road maps to nematode diversity. *Nematology* 2: 9-16.
- De Ley P, Félix M-A, Frisse LM, Nadler SA, Sternberg PW, Thomas WK (1999) Molecular and morphological characterization of two reproductively isolated species with mirror-image anatomy (Nematoda:Cephalobidae). *Nematology* 1: 591-612.
- De Ley P, Bert W (2002) Video capture and editing as a tool for the storage, distribution, and illustration of morphological characters of nematodes. *J Nematol* 34: 296-302.
- De Ley P, Blaxter M (2003) A new system for Nematoda: combining morphological characters with molecular trees, and translating clades into ranks and taxa. *Nematol Monogr Persp* 2: 1-21.
- De Ley P, Tandingan De Ley I, Morris K, Abebe E, Mundo-Ocampo M, Yoder M, Heras J, Waumann D, Rocha-Olivares A, Burr AH, Baldwin JG, Thomas WK (2005) An integrated approach to fast and informative morphological vouchering of nematodes for applications in molecular barcoding. *Phil Trans R Soc Lond B* 360: 1945-1958.
- De Meester L, Gomez A, Okamura B, Schwenk K (2002) The Monopolization Hypothesis and the dispersal-gene flow paradox in aquatic organisms. *Acta Oecol* 23: 121-135.
- De Mesel I, Derycke S, Swings J, Vincx M, Moens T (2003) Influence of bacterivorous nematodes on the decomposition of cordgrass. *J Exp Mar Biol Ecol* 296: 227-242.
- De Mesel I. (2004) Nematodes associated with phytodetritus in salt marshes. Colonisation patterns and species- and diversity related impacts on decomposition processes. PhD thesis. University of Ghent.
- De Mesel I, Derycke S, Moens T, Van der Gucht K, Vincx M, Swings J (2004) Top-down impact of bacterivorous nematodes on the bacterial community structure: a microcosm study. *Environ Microbiol* 6: 733-744.
- De Mesel I, Derycke S, Swings J, Vincx M, Moens T (2006) Role of nematodes in decomposition processes: does within-trophic group diversity matter? *Mar Ecol Prog Ser* 321: 157-166.

## CITED LITERATURE

---

- de Queiroz K (1998) The general lineage concept of species, species criteria, and the process of speciation. In: Howard DJ, S. H: Berlocher eds. *Endless forms: species and speciation*. New York/Oxford: Oxford Univ. Press, 57-75.
- de Queiroz K (2005) Ernst Mayr and the modern concept of species. *Proc Natl Acad Sci USA* 102: 6600-6607.
- De Wolf H, Jordaens K, Reusens E, Blust R, Backeljau T (2001) Esterase variation in the periwinkle *Littorina littorea*, along the western and eastern Scheldt estuary. *Mar Environ Res* 52: 373-382.
- De Wolf H, Backeljau T, Blust R (2002) Sensitivity to cadmium along a salinity gradient in populations of the periwinkle, *Littorina littorea*, using time-to-death analysis. *Aquat Toxicol* 66: 241-253.
- De Wolf H, Blust R, Backeljau T (2004) The use of RAPD in ecotoxicology. *Mutat Res* 566: 249-262.
- De Wolf H, Blust R, Backeljau T (2004) The population genetic structure of *Littorina littorea* (Mollusca: Gastropoda) along a pollution gradient in the Scheldt estuary (The Netherlands) using RAPD analysis. *Sci Total Environ* 325: 59-69.
- Denver DR, Morris K, Lynch M, Vassilieva LL, Thomas Wk (2000) High direct estimate of the mutation rate in the mitochondrial genome of *Caenorhabditis elegans*. *Science* 289: 2342-2344.
- Derycke S, Remerie T, Vierstraete A, Backeljau T, Vanfleteren J, Vincx M, Moens T (2005) Mitochondrial DNA variation and cryptic speciation within the free-living marine nematode *Pellioditis marina*. *Mar Ecol Progr Ser* 300: 91-103.
- Derycke S, Backeljau T, Vlaeminck C, Vierstraete A, Vanfleteren J, Vincx M, Moens T (2006) Seasonal dynamics of population genetic structure in cryptic taxa of the *Pellioditis marina* complex (Nematoda: Rhabditida). *Genetica* 128: 307-321.
- Derycke S, Backeljau T, Vlaeminck C, Vierstraete A, Vanfleteren J, Vincx M, Moens T (2007a) Spatiotemporal analysis of population genetic structure in *Geomonhystera disjuncta* (Nematoda, Monhysteridae) reveals high levels of molecular diversity. *Mar Biol*, in press.
- Derycke S, Van Vynckt R, Vanoverbeke J, Vincx M, Moens T (2007b) Colonisation patterns of Nematoda on decomposing algae in the estuarine environment: Community assembly and genetic structure of the dominant species *Pellioditis marina*. *Limnol Oceanogr*, in press.
- Dolphin K, Belshaw R, Orme CDL, Quicke DLJ (2000) Noise and incongruence: interpreting results of the incongruence length difference test. *Mol Phylog Evol* 17: 401-406.

- Donald KM, Kennedy M, Spencer HG (2005) Cladogenesis as the result of long-distance rafting events in south Pacific topshells (Gastropoda, Trochidae). *Evolution* 59: 1701-1711.
- Ducrottoy JP, Elliott M, de Jonge VN (2000) The North Sea. *Mar Pollut Bull* 41: 5-23.
- Dupanloup I, Schneider S, Excoffier L (2002) A simulated annealing approach to define the genetic structure of populations. *Mol Ecol* 11:2571-2581.
- Ekschmitt K, Griffiths B (1998) Soil biodiversity and its implications for ecosystem functioning in a heterogeneous and variable environment. *App Soil Ecol* 10: 201-215.
- Emmerson MC, Solan M, Emes C, Paterson DM, Raffaelli D (2001) Consistent patterns and the idiosyncratic effects of biodiversity in marine ecosystems. *Nature* 411: 73-77.
- Excoffier L, Smouse P, Quattro J (1992) Analysis of molecular variance inferred from metric distances among DNA haplotypes: Application to human mitochondrial DNA restriction data. *Genetics* 131: 479-491.
- Faust MA, Gullede RA (1996) Associations of microalgae and meiofauna in floating detritus at a mangrove island, Twin Cays, Belize. *J Exp Mar Biol Ecol* 22: 115-123.
- Fegley S (1987) Experimental variation of near-bottom current speeds and its effects on depth distribution of sand-living meiofauna. *Mar Biol* 95: 183-191.
- Felsenstein J (2004) PHYLIP: Phylogeny inference package v 3.6, University of Washington, USA.
- Ferguson JWH (2002) On the use of genetic divergence for identifying species. *Biol J Lin Soc* 75: 509-516.
- Ferris VR, Ferris JM, Faghihi J (1993) Variation in spacer ribosomal DNA in some cyst-forming species of plant-parasitic nematodes. *Fund Appl Nemat* 16: 177-184.
- Floyd R, Abebe E, Papert A, Blaxter M (2002) Molecular barcodes for soil nematode identification. *Mol Ecol* 11: 839-850.
- Fonseca G, Vanreusel A., Decraemer W (2006) Taxonomy and biogeography of *Molgolaimus* Ditlevsen, 1921 (Nematoda: Chromadoria) with reference to the origins of deep sea nematodes. *Antarct Sci* 18: 23-50.
- Forbes VE, Calow P (2002) Population growth rate as a basis for ecological risk assessment of toxic chemicals. *Philos Trans R Soc Lond B* 357: 1299-1306.

## CITED LITERATURE

---

- Forster SJ (1998) Osmotic stress tolerance and osmoregulation of intertidal and subtidal nematodes. *J Exp Mar Biol Ecol* 224: 109-125.
- Fu YX (1997) Statistical tests of neutrality of mutations against population growth, hitchhiking and background selection. *Genetics* 147: 915-925.
- Gagarin VG (2001) A new species of nematodes found in rotting seaweed on the shore of the Black Sea. *Russ J Mar Biol* 27: 259-261.
- Garcia-Marin JL, Utter FM, Pla C (1999) Postglacial colonisation of brown trout in Europe based on distribution of allozyme variants. *Heredity* 82: 46-56.
- Gardeström J, Gorokhova E, Gilek M, Grahn M, Bengtsson BE, Breitholz M (2006) A multilevel approach to predict toxicity in copepod populations: assessment of growth, genetics, and population structure. *Aquat Toxicol* 79: 41-48.
- Gerlach SA (1965) Freilebende Meeresnematoden aus der Gezeitenzone von Spitzbergen. *Veröff Inst Meeresforsch Bremerh* 9: 109-172.
- Gerlach SA (1977) Means of meiofaunal dispersal. *Mikr Meeresb* 61: 89-103.
- Giere O (1993) Meiobenthology. The microscopic fauna in aquatic sediments. Springer, Berlin.
- Gillespie RB, Guttman SI (1999) Chemical-induced changes in the genetic structure of populations: effects on allozymes. In: Forbes VE (Ed.), *Genetics and Ecotoxicology*, Taylor & Francis, Philadelphia, pp. 55-77.
- Gittenberger E (1991) What about non-adaptive radiation? *Biol J Lin Soc* 43:263-272.
- Godfray HCJ (2002) Challenges for taxonomy - the discipline will have to reinvent itself if it is to survive and flourish. *Nature* 417: 17-19.
- Gómez A, Wright PJ, Lunt DH, Cancino JM, Carvalho GR, Hughes RN (2007) Mating trials validate the use of DNA barcoding to reveal cryptic speciation of a marine bryozoan taxon. *Proc R Soc B* 274: 199-207.
- Goudet J (2001) FSTAT, a program to estimate and test gene diversities and fixation indices (version 2.9.3). Lausanne, Switzerland.
- Govindarajan AL, Piraino S, Gravili C, Kubota S (2005) Species identification of bivalve-inhabiting marine hydrozoans of the genus *Eugymnanthea*. *Invert Biol* 124: 1-10.

- Gysels ES, Hellemans B, Pampoulie C, Volckaert FAM (2004) Phylogeography of the common goby, *Pomatoschistus microps*, with particular emphasis on the colonisation of the Mediterranean and the North Sea. *Mol Ecol* 13: 403-417.
- Haag C, Riek M, Hottinger J, Pajunen V, Ebert D (2006) Founder events as determinants of within-island and among-island genetic structure of *Daphnia* metapopulations. *Heredity* 96: 150-158.
- Halupa PJ, Howes BL (1995) Effects of tidally mediated litter moisture content on decomposition of *Spartina alterniflora* and *Spartina patens*. *Mar Biol* 123: 379-391.
- Han HR, Jeyaprakash A, Weingartner DP, Dickson DW (2006) Morphological and molecular biological characterization of *Belonolaimus longicaudatus*. *Nematropica* 36: 37-52.
- Hanski I (1991) Single-species metapopulation dynamics. Brief history and conceptual domain. *Biol J Linn Soc* 42: 17-38.
- Hanski I, Gilpin M (1997) Metapopulation biology. Ecology, genetics, and evolution. Academic Press.
- Harrison S, Hastings A (1996) Genetic and evolutionary consequences of metapopulation structure. *Trends Ecol Evol* 11: 180-183.
- Hart MW, Keever CC, Datnall AJ, Byrne M (2006) Morphological and genetic variation indicate cryptic species within Lamarck's little sea star, *Parvulastra* (= *Patiriella*) *exigua*. *Biol Bull* 210: 158-167.
- Hartl DL, Clark AG (1989) Principles of population genetics, 2<sup>nd</sup> edn., Sinauer Associates, Sunderland.
- Hartl DL (2000) A primer of population genetics. Sinauer Associates, Sunderland.
- Hasegawa M, Kishino K, Yano T (1985) Dating the human-ape splitting by a molecular clock of mitochondrial DNA. *J Mol Evol* 22: 160-174.
- Heath DD, Busch C, Kelly J, Atagi DY (2002) Temporal change in genetic structure and effective population size in steelhead trout (*Oncorhynchus mykiss*). *Mol Ecol* 11: 197-214.
- Hebert PDN, Cywinska A, Ball SL, deWaard JR (2003a) Biological identifications through DNA barcodes. *Proc R Soc Lond B* 270: 313-321.

## CITED LITERATURE

---

- Hebert PDN, Ratnasingham S, deWaard JR (2003b) Barcoding animal life: cytochrome c oxidase subunit 1 divergences among closely related species. *Proc R Soc Lond B (suppl)* 270: 96-99.
- Hebert PDN, Stoeckle MY, Zemlak TS, Francis CM (2004) Identification of birds through DNA barcodes. *PLOS Biol* 2: 1657-1633.
- Hebert PDN, Gregory TR (2005) The promise of DNA barcoding for taxonomy. *Syst Biol* 54: 852-859.
- Heip C, Herman R, Vincx M (1984) Variability and productivity of meiobenthos in the southern bight of the North Sea. *Rapp P.-v. Réun Cons int Explor Mer* 183: 51-56.
- Heip C, Vincx M, Vranken G (1985) The ecology of marine nematodes. *Oceanogr Mar Biol Annu Rev* 23: 399-489.
- Heip C (1989) The ecology of the estuaries Rhine, Meuse and Scheldt in The Netherlands. *Top Mar Biol* 53: 457-463.
- Hellberg ME (1996) Dependence of gene flow on geographic distance in two solitary corals with different larval dispersal capabilities. *Evolution* 50: 1167-1175.
- Herman PMJ, Vranken G (1988) Studies of the life-history and energetics of marine and brackish-water nematodes. II: Production, respiration and food uptake by *Monhystera disjuncta*. *Oecologia* 77: 457-463.
- Hey J (1991) The structure of genealogies and the distribution of fixed differences between DNA sequence samples from natural populations. *Genetics* 128: 831-840.
- Hewitt GM (1996) Some genetic consequences of ice ages, and their role in divergence and speciation. *Biol J Linn Soc* 58: 247-276.
- Hewitt GM (2000) The genetic legacy of the Quaternary ice ages. *Nature* 405: 907-913.
- Hicks GRF, Coull BC (1983) The ecology of marine meiobenthic harpacticoid copepods. *Oceanogr Mar Biol Annu Rev* 21: 67-175.
- Higgins DG, Bleasby AJ, Fuchs R (1991) Clustal V: improved software for multiple sequence alignment. *Cabios* 8: 189-191.
- Hillis DM, Dixon MT (1991) Ribosomal DNA: molecular evolution and phylogenetic inference. *Q Rev Biol* 66: 411-437.



- Hillis DM, Moritz C, Porter CA, Baker RJ (1991) Evidence for biased gene conversion in concerted evolution of ribosomal DNA. *Science* 251: 308-310.
- Hoberg EP, Monsen KJ, Kutz S, Blouin MS (1999) Structure, biodiversity and historical biogeography of nematode faunas in holarctic ruminants: morphological and molecular diagnoses for *Teladorsagia boreoarcticus* sp. n. (Nematoda: Ostertagiinae), a dimorphic cryptic species in muskoxen (*Ovibos moschatus*). *J Parasitol* 85: 910-934.
- Hodgkin J, Kuwabara PE, Corneliussen B (2000) A novel bacterial pathogen, *Microbacterium nematophilum*, induces morphological change in the nematode *C. elegans*. *Curr Biol* 10: 1615-1618.
- Hoffman EA, Schueler FW, Blouin MS (2004) Effective population sizes and temporal stability of genetic structure in *Rana pipiens*, the northern leopard frog. *Evolution* 58: 2536-2545.
- Hoglund J, Engstrom A, Morrison DA, Mattson JG (2004) Genetic diversity assessed by amplified fragment length polymorphism analysis of the parasitic nematode *Dictyocaulus viviparus*, the lungworm of cattle. *Int J Parasitol* 34: 475-484.
- Hohenlohe PA (2004) Limits to gene flow in marine animals with planktonic larvae: models of *Littorina* species around Point Conception, California. *Biol J Linn Soc* 82: 169-187.
- Holzmann M (2000) Species concept in foraminifera: *Ammonia* as a case study. *Micropaleontology* 46: 21-37.
- Hopper BE (1969) Marine nematodes of Canada II. Marine nematodes from the Minas Basin-Scots Bay area of the bay of Fundy, Nova Scotia. *Can J Zool* 46:655-661.
- Howell KL, Rogers AD, Tyler PA, Billett DSM (2004) Reproductive isolation among morphotypes of the Atlantic seastar species *Zoroaster fulgens* (Asteroidea: Echinodermata). *Mar Biol* 144: 977-984.
- Hu M, Chilton NB, Zhu XQ, Gasser RB (2002) Single-strand conformation polymorphism-based analysis of mitochondrial cytochrome c oxidase subunit 1 reveals significant substructuring in hookworm populations. *Electrophoresis* 23: 27-34.
- Huelsensbeck JP, Ronquist F (2005) Mr Bayes v 3.1.2, Bayesian Analysis of Phylogeny. University of California, San Diego and Florida State University.
- Hugot JP, Baujard P, Morand S (2001) Biodiversity in helminthes and nematodes as a field of study: an overview. *Nematology* 3: 199-208.

- Huisman J, Weissing FJ (1999) Biodiversity of plankton by species oscillations and chaos. *Nature* 402: 407-410.
- Inglis WG, Coles JW (1961) The species of *Rhabditis* (Nematoda) found in rotting seaweed on British beaches. *Bull Br Mus (Nat Hist). Zool* 7: 320-333.
- Jacobs L (1987) A checklist of the Monhysteridae (Nematoda, Monhysterida), Rand Afrikaans University, Johannesburg.
- Jenkins D, Buikema A (1998) Do similar communities develop in similar sites? A test with zooplankton structure and function. *Ecol Monogr* 68: 421-443.
- Jensen P (1987) Feeding ecology of free-living aquatic nematodes. *Mar Ecol Prog Ser* 35: 187-196.
- Johannes RE (1965) The influence of marine protozoa on nutrient regeneration. *Limnol Oceanogr* 12: 189-195.
- Johnson KH, Vogt KA, Clark HJ, Schmitz OJ, Vogt DJ (1996) Biodiversity and the productivity and stability of ecosystems. *Trends Ecol Evol* 11: 372-377.
- Jolly MT, Jollivet D, Gentil F, Thiébout E, Viard F (2005) Sharp genetic break between Atlantic and English Channel populations of the polychaete *Pectinaria koreni*, along the North coast of France. *Heredity* 94: 23-32.
- Jorde PE, Ryman N (1996) Demographic genetics of Brown trout (*Salmo trutta*) and estimation of effective population size from temporal change of allele frequencies. *Genetics* 143: 1369-1381.
- Kanda N, Allendorf FW (2001) Genetic population structure of bull trout from the flathead river basin as shown by microsatellites and mitochondrial DNA markers. *Trans Am Fish Soc* 130: 92-106.
- Kaplan DT (1994) Molecular characterization of the burrowing nematode sibling species, *Radopholus citrophilus* and *R. similis*. In: Lamberti F, De Giorgi C, Bird DM, eds. *Advances in molecular plant nematology*. New York: Plenum Press, 77-83.
- Kelly DW, MacIsaac HJ, Heath DD (2006) Vicariance and dispersal effects on phylogeographic structure and speciation in a widespread estuarine invertebrate. *Evolution* 60: 257-267.
- Khazaeli MB, Mitra RS (1981) Cadmium-binding component in *Escherichia coli* during accommodation to low levels of this ion. *Appl Environ Microbiol* 41: 46-50.

- Kim SJ, Rodriguez-Lanetty M, Suh JH, Song JI (2003). Emergent effects of heavy metal pollution at a population level: *Littorina brevicula*, a study case. *Mar Pollut Bull* 46: 74-80.
- Kimura M (1981) Estimation of evolutionary distances between homologous nucleotide sequences. *Proc Natl Acad Sci USA* 78: 454-458.
- Kirkendale LA, Meyer CP (2004) Phylogeography of the *Patelloida profunda* group (Gastropoda: Lottidae): diversification in a dispersal-driven marine system. *Mol Ecol* 13: 2749-2762.
- Kliman RM, Hey J (1993) DNA sequence variation at the *period* locus within and among species of the *Drosophila melanogaster* complex. *Genetics* 133: 375-387.
- Knowlton N (1993) Sibling species in the sea. *Annu Rev Ecol Syst* 24: 189-199.
- Knowlton N (2000) Molecular genetic analysis of species boundaries in the sea. *Hydrobiologia* 420: 73-90.
- Kovatch CE, Schizas NV, Chandler T, Coull BC, Quattro JM (2000) Tolerance and genetic relatedness of three meiobenthic copepod populations exposed to sediment-associated contaminant mixtures: Role of environmental history. *Environ Toxicol Chem* 19: 912-919.
- Kuipers BR, de Wilde PAWJ, Creutzberg F (1981) Energy flow in a tidal ecosystem. *Mar Ecol Progr Ser* 5: 215-221.
- Kumar S, Tamura K, Nei M (2004) MEGA3: Integrated software for molecular evolutionary genetics analysis and sequence alignment. *Briefings in Bioinformatics* 5: 150-163.
- Lamshead PJD (1993) Recent developments in marine benthic biodiversity research. *Oceanis* 19: 5-24.
- Lamshead PJD, Boucher G. (2003) Marine nematode deep-sea biodiversity - hyperdiverse or hype? *J Biogeogr* 30: 475-485.
- Lamshead PJD (2004) Marine nematode biodiversity. In: *Nematode morphology, physiology and ecology* (ed. ZX Chen, SY Chen, DW Dickson), vol 1, pp 438-492. Tsinghua University Press.
- Latta RG, Linhart YB, Mitton JB (2001) Cytonuclear disequilibrium and genetic drift in a natural population of Ponderosa Pine. *Genetics* 158: 843-850.

## CITED LITERATURE

---

- Lee CE (2000) Global phylogeography of a cryptic copepod species complex and reproductive isolation between genetically proximate 'populations'. *Evolution* 54: 2014-2027.
- Lee T, O' Foighil D (2004) Hidden Floridian biodiversity: mitochondrial and nuclear gene trees reveal four cryptic species within the scorched mussel, *Brachidontes exustus*, species complex. *Mol Ecol* 13: 3527-3542.
- Le Gac M, Féral JP, Poulin E, Veyret M, Chenuil A (2004) Identification of allopatric clades in the cosmopolitan ophiuroid species complex *Amphipholis squamata* (Echinodermata). The end of a paradox? *Mar Ecol Prog Ser* 278: 171-178.
- Lessios HA, Kessing BD, Robertson DR (1998) Massive gene flow across the world's most potent marine biogeographic barrier. *Proc R Soc Lond B* 265: 583-588.
- Lessios HA, Kessing BD, Pearse JS (2001) Population structure and speciation in tropical seas: global phylogeography of the sea urchin *Diadema*. *Evolution* 55: 955-975.
- Lipscomb D, Platnick N, Wheeler Q (2003) The intellectual content of taxonomy: a comment on DNA taxonomy. *Trends Ecol Evol* 18: 65-66.
- Loreau M, Naeem S, Inchausti P, Bengtsson J, Grime JP, Hector A, Hooper DU, Huston MA, Raffaelli D, Schmid B, Tilman D, Wardle DA (2001) Ecology-Biodiversity and ecosystem functioning: current knowledge and future challenges. *Science* 294: 804-808.
- Löytynoja A, Milinkovitch MC (2001) SOAP, cleaning multiple alignments from unstable blocks. *Bioinformatics* 17: 573-574.
- Lundholm N, Moestrup O (2006) Inter- and intraspecific variation of the *Pseudonitzschia delicatissima* complex (Bacillariophyceae) illustrated by rRNA probes, morphological data and phylogenetic analyses. *J Phycol* 42: 464-481.
- Luttikhuisen PC, Drent J, Baker AJ (2003) Disjunct distribution of highly diverged mitochondrial lineage clade and population subdivision in a marine bivalve with pelagic larval dispersal. *Mol Ecol* 12: 2215-2229.
- Maier E, Tollrian R, Rinkevich B, Nurnberger B (2005) Isolation by distance in the scleractinian coral *Seriatopora hystrix* from the Red Sea. *Mar Biol* 147: 1109-1120.
- Malhotra A, Thorpe RS (2004) Maximising information in systematic revisions: a combined molecular and morphological analysis of a cryptic green pitviper complex (*Trimeresurus stejnegeri*). *Biol J Linn Soc* 82: 219-235.

- Mallet J (1995) A species definition for the modern synthesis. *Trends Ecol Evol* 10: 294-99.
- Mallet J, Willmott K (2003) Taxonomy: renaissance or Tower of Babel? *Trends Ecol Evol* 18: 57-59.
- Markmann M, Tautz D (2005) Reverse taxonomy: an approach towards determining the diversity of meiobenthic organisms based on ribosomal RNA signature sequences. *Philos Trans R Soc Lond B* 360:1917-1924.
- Martin AP, Palumbi SR (1993) Body size, metabolic rate, generation time, and the molecular clock. *Proc Natl Acad Sci* 90: 4087-4091.
- Martínez P, Belcari P, Sanjuan A, Guerra A (2005) Allozyme analysis of geographical and seasonal variation of *Ilex coindetii* (Cephalopoda: Ommastrephidae) from central Mediterranean and Iberian Atlantic. *J Mar Biol Ass UK* 85: 177-184
- Mathews LM, Schubart CD, Neigel JE, Felder DL (2002) Genetic, ecological, and behavioural divergence between two sibling snapping shrimp species (Crustacea: Decapoda: *Alpheus*). *Mol Ecol* 11: 1427-1437.
- Mathews LM (2006) Cryptic biodiversity and phylogeographical patterns in a snapping shrimp species complex. *Mol Ecol* 15: 4049-4063.
- Mc Elroy TC, Kandl KL, Garcia L, Trexler JC (2003) Extinction-colonisation dynamics structure genetic variation of spotted sunfish (*Lepomis punctatus*) in the Florida Everglades. *Mol Ecol* 12:355-368.
- McGovern TM, Hellberg ME (2003) Cryptic species, cryptic endosymbionts, and geographical variation in chemical defences in the bryozoan *Bugula neritina*. *Mol Ecol* 12: 1207-1215.
- Mickevich ME, Farris JS (1981) The implications of congruence in Menidia. *Syst Zool* 27: 143-158.
- Middelburg JJ, Barranguet C, Boschker HTS, Herman PMJ, Moens T, Heip CHR (2000) The fate of intertidal microphytobenthos carbon: an in situ C-13-labeling study. *Limnol Oceanogr* 45: 1224-1234.
- Miller MP (1997) Tools for population genetic analysis (TFPGA) 1.3 A Windows program for the analysis of allozyme and molecular population genetic data. Department of Biological Sciences, Northern Arizona University.
- Millward RN, Grant A (1995) Assessing the impact of copper on nematode communities from a chronically metal-enriched estuary using pollution-induced community tolerance. *Mar Pollut Bull* 30: 701-706.

## CITED LITERATURE

---

- Moens T, Vierstraete A, Vincx M (1996) Life strategies in two bacterivorous marine nematodes: preliminary results. *Mar Ecol* 17: 509-518.
- Moens T, Vincx M (1997) Observations on the feeding ecology of estuarine nematodes. *J Mar Biol Ass UK* 77: 211-227.
- Moens T, Vincx M (1998) On the cultivation of free-living marine and estuarine nematodes. *Helgol Meeresunters* 52: 115-139.
- Moens T (1999) Feeding ecology of free-living estuarine nematodes. Phd, University of Ghent, Belgium, pp. 302.
- Moens T, Vincx M (2000a) Temperature and salinity constraints on the life cycle of two brackish-water nematode species. *J Exp Mar Biol Ecol* 243: 115-135.
- Moens T, Vincx M (2000b) Temperature, salinity and food thresholds in two brackish-water bacterivorous nematode species: assessing niches from food absorption and respiration experiments. *J Exp Mar Biol Ecol* 243: 137-154.
- Moens T, Yeates GW, De Ley P (2004) Use of carbon and energy sources by nematodes, p.529-545. *In*: R. Cook and D.J. Hunt [eds.], *Nematology Monographs and Perspectives - Proceedings of the fourth International Congress of Nematology*, 8-13 June 2002, Tenerife, Spain Volume 2. Brill, Leiden.
- Moens T, dos Santos GAP, Thompson F, Swings J, Fonseca-Genevois V, Vincx M, De Mesel I (2005) Do nematode mucus secretions affect bacterial growth? *Aquat Microb Ecol* 40: 77-83.
- Mokievsky VO, Filippova KA, Chesunov AV (2005) Nematode fauna associated with detached kelp accumulations in the subtidal zone of the White Sea. *Oceanology* 45: 689-697.
- Monteiro LR, Bordin B, dos Reis SF (2000) Shape distances, shape spaces and the comparison of morphometric methods. *Trends Ecol Evol* 15: 217- 220.
- Murdoch MH, Hebert PDN (1994) Mitochondrial DNA diversity of brown bullhead from contaminated and relatively pristine sites in the great lakes. *Environ Toxicol Chem* 13: 1281-1289.
- Nadler SA (2002) Species delimitation and nematode biodiversity: phylogenies rule. *Nematology* 4: 615-625.
- Naeem S, Wright JP (2003) Disentangling biodiversity effects on ecosystem functioning: deriving solutions to a seemingly insurmountable problem. *Ecol Lett* 6: 567-579.

- Nei M (1987) Molecular evolutionary genetics. Columbia University Press, New York, NY, USA.
- Newell SY, Fallon RD, Cal Rodrigua RM, Groene LC (1985) Influence of rain, tidal wetting and relative humidity on release of carbon dioxide by standing-dead salt marsh plants. *Oecologia* 68: 73-79.
- Nguyen KB, Gozel U, Koppenhofer HS, Adams BJ (2006) *Heterorhabditis floridensis* n. sp. (Rhabditida, Heterorhabditidae) from Florida. *Zootaxa* 1177: 1-19.
- Nguyen KB, Maruniak J, Adams BJ (2001) Diagnostic and phylogenetic utility of the rDNA internal transcribed spacer sequences of *Steinernema*. *J Nematol* 33: 73-82.
- Nielsen C (1998) Sequences lead to tree of worms. *Nature* 392: 25-26.
- Nielsen EE, Hansen MM, Ruzzante DE, Meldrup D, Grønkjær P (2003) Evidence of a hybrid-zone in Atlantic cod (*Gadus morhua*) in the Baltic and the Danish Belt Sea revealed by individual. *Mol Ecol* 12: 1497-1508.
- Nielsen EE, Nielsen PH, Meldrup D, Hansen MM (2004) Genetic population structure of turbot (*Scophthalmus maximus* L.) supports the presence of multiple hybrid zones for marine fishes in the transition zone between the Baltic Sea and the North Sea. *Mol Ecol* 13: 585-595.
- Nicholas KB, Nicholas HB (1997) Genedoc: a tool for editing and annotating multiple sequence alignments.
- Nichols RA, Hewitt GM (1994) The genetic consequences of long distance dispersal during colonisation. *Heredity* 72: 312-317.
- Nieberding C, Libois R, Douady CJ, Morand S, Michaux J.R. (2005) Phylogeography of a nematode (*Heligmosomoides polygyrus*) in the western Palearctic region: persistence of northern cryptic populations during ice ages? *Mol Ecol* 14: 765-779.
- Nylander JA (2001) Taxon sampling in phylogenetic analysis: problems and strategies reviewed. Introductory Research essay 1, Uppsala University, Sweden.
- Nylander JA (2004) MrModeltest v2. Program distributed by the author. Evolutionary Biology Centre, Uppsala University.
- Ó Foighil D, Marshall BA, Hilbish TJ, Pino MA (1999) Trans-Pacific range extension by rafting inferred for the flat oyster *Ostrea chilensis*. *Biol Bull* 196: 122-126.

- Olsen JL, Stam WT, Coyer JA, Reusch TBH, Billingham M, Boström C, Calvert E, Christie H, Granger S, La Lumière R, Milchakova N, Oudot-Le Secq MP, Procaccini G, Sanjabi B, Serrão E, Veldsink J, Iddicombe S, Wyllie-Echeverria S (2004) North Atlantic phylogeography and large-scale population differentiation of the seagrass *Zostera marina* L. *Mol Ecol* 13: 1923-1941.
- Omilian Ar, Taylor DJ (2001) Rate acceleration and long-branch attraction in a conserved gene of cryptic Daphniid (Crustacea) species. *Mol Biol Evol* 18: 2201-2212.
- Orita M, Iwahana H, Kanazawa H, Hayashi K, Sekiya T (1989) Detection of polymorphisms of human DNA by gel electrophoresis as single-strand conformation polymorphisms. *Proc Natl Acad Sci USA* 86: 2766-2770.
- Ostergaard S, Hansen MM, Loeschcke V, Nielsen EE (2003) Long – term temporal changes of genetic composition in brown trout (*Salmo trutta* L.) population inhabiting an unstable environment. *Mol Ecol* 12: 3123-3135.
- Otranto D, Testini G, De Luca F, Hu M, Shamsi S, Gasser RB (2005) Analysis of genetic variability within *Thelazia callipaeda* (Nematoda: Thelazioidea) from Europe and Asia by sequencing and mutation scanning of the mitochondrial cytochrome c oxidase subunit 1 gene. *Mol Cell Probes* 19: 306-313.
- Ovenden JR, Salini J, O'Connor S, Street R (2004) Pronounced genetic population structure in a potentially vagile fish species (*Pristipomoides multidens*, Teleostei; Perciformes; Lutjanidae) from the East Indies triangle. *Mol Ecol* 13: 1991-1999.
- Page TJ, Baker AM, Cook BD, Hughes JM (2005) Historical transoceanic dispersal of a freshwater shrimp: the colonisation of the South Pacific by the genus *Paratyta* (Atyidae). *J Biogeogr* 32: 581-593.
- Palumbi SR (1992) Marine speciation on a small planet. *Trends Ecol Evol* 7: 114-118.
- Palumbi SR (1994) Genetic divergence, reproductive isolation, and marine speciation. *Annu Rev Ecol Syst* 25: 547-572.
- Palumbi SR (1995) Using genetics as an indirect estimator of larval dispersal. In: *Ecology of Marine Invertebrate Larvae* (ed. McEwards LR), pp 396-487.
- Parmakelis A, Spanos E, Papagiannakis G, Louis C, Mylonas M (2003) Mitochondrial DNA phylogeny and morphological diversity in the genus *Mastus* (Beck, 1837): a study in a recent (Holocene) island group (Koufonisi, south-east Crete). *Biol J Linn Soc* 78: 383-399.
- Papetti C, Zane L, Bortolotto E, Bucklin A, Patarnello T (2005) Genetic differentiation and local temporal stability of population structure in the euphausiid *Meganyctiphanes norvegica*. *Mar Ecol Prog Ser* 289: 225-235.



- Peijnenburg KTC, Breeuwer JAJ, Pierrot-Bults AC, Menken SBJ (2004) Phylogeography of the planktonic chaetognath *Sagitta setosa* reveals isolation in European seas. *Evolution* 58: 1472-1487.
- Perrin C, Wing SR, Roy MS (2004) Effects of hydrographic barriers on population genetic structure of the sea star *Coscinasterias muricata* (Echinodermata, Asteroidea) in the New Zealand fiords. *Mol Ecol* 13: 2183-2195.
- Picard D, Plantard O, Scurrah M, Mugniéry D (2004) Inbreeding and population structure of the potato cyst nematode (*Globodera pallida*) in its native area (Peru). *Mol Ecol* 13: 2899-2908.
- Pinceel J, Jordaens K, Van Houtte N, De Winter AJ, Backeljau T (2004) Molecular and morphological data reveal cryptic taxonomic diversity in the terrestrial slug complex *Arion subfuscus/fuscus* (Mollusca, Pulmonata, Arionidae) in continental north-west Europe. *Biol J Linn Soc* 83: 23-38.
- Pinceel J, Jordaens K, Backeljau T (2005) Extreme mtDNA divergences in a terrestrial slug (Gastropoda, Pulmonata, arionidae): accelerated evolution, allopatric divergence and secondary contact. *J Evol Biol* 18: 1264-1280.
- Plantard O, Porte C (2004) Population genetic structure of the sugar beet cyst nematode *Heterodera schachtii*: a gonochoristic and amphimictic species with highly inbred but weakly differentiated populations. *Mol Ecol* 13: 33-41.
- Platt HM (1994) Foreword. In: *The phylogenetic systematics of free-living nematodes* (ed. S. Lorenzen). London, The Ray Society.
- Popham JD, Webster JH (1979). Cadmium toxicity in the free-living nematode *Caenorhabditis elegans*. *Environ Res* 20: 183-191.
- Posada D, Crandall KA (1998) Modeltest: testing the model of DNA substitution. *Bioinformatics* 14: 817-818.
- Posada D, Crandall KA, Templeton AR (2000) GeoDis: A program for the Cladistic Nested Analysis of the geographical distribution of genetic haplotypes. *Mol Ecol* 9:487-488.
- Posada D, Buckley TR (2004) Model selection and model averaging in phylogenetics: advantages of Akaike information criterion and Bayesian approaches over likelihood ratio tests. *Syst Biol* 53: 793-808.
- Powers TO, Todd TC, Burnell AM, Murray PCB, Fleming CC, Szalanski AL, Adams BA, Harris TS (1997) The internal transcribed spacer region as a taxonomic marker for nematodes. *J Nematol* 29: 441-450.

- Powers T (2004) Nematode molecular diagnostics: from bands to barcodes. *Annu Rev Phytopathol* 42: 367-383.
- Provan J, Wattier RA, Maggs CA (2005) Phylogeographic analysis of the red seaweed *Palmaria palmate* reveals a Pleistocene marine glacial refugium in the English Channel. *Mol Ecol* 14:793-803.
- Puerto G, Salomao MG, Theakston RDG, Thorpe RS, Warrell DA, Wüster W (2001) Combining mitochondrial DNA sequences and morphological data to infer species boundaries: phylogeography of lancehead pitvipers in the Brazilian Atlantic forest, and the status of *Bothrops pradoi* (Squamata: Serpentes: Viperidae). *J Evol Biol* 14: 527-38.
- Quesada H, Wenne R, Skibinski DO (1999) Interspecies transfer of female mitochondrial DNA is coupled with role-reversals and departures from neutrality in the mussel *Mytilus trossulus*. *Mol Biol Evol* 16: 655-665.
- Radice AD, Powers TO, Sandall LJ, Riggs RD (1988) Comparisons of mitochondrial DNA from the sibling species *Heterodera glycines* and *H. schachtii*. *J Nematol* 20: 443-450.
- Remerie T (2005) Molecular diversity and population structure of two mysid taxa along European coasts. Phd, University of Gent, Belgium.
- Remerie T, Bourgois T, Peelaers D, Vierstraete A, Vanfleteren J, Vanreusel A (2006a) Phylogeographic patterns of the mysid *Mesopodopsis slabberi* (Crustacea, Mysida) in Western Europe: evidence for high molecular diversity and cryptic speciation. *Mar Biol* 149: 465-481.
- Remerie T, Gysels E, Vierstraete A, Vanfleteren J, Vanreusel A (2006b) Evidence of genetic differentiation of the brackish water mysid *Neomysis integer* (Crustacea, Mysida) concordant with Pleistocene glaciations. *Vie Milieu* 56: 15-22.
- Rice WR (1989) Analyzing Tables of statistical tests. *Evolution* 43: 223-225.
- Riemann F, Helmke E (2002) Symbiotic relations of sediment-agglutinating nematodes and bacteria in detrital habitats: the enzyme-sharing concept. *Mar Ecol* 23: 93-113.
- Rocha LA, Robertson DR, Roman J, Bowen BW (2005) Ecological speciation in tropical reef fish. *Proc R Soc Lond Ser B* 272: 573-579.
- Rocha-Olivares A, Fleegeer JW, Foltz DW (2001). Decoupling of molecular and morphological evolution in deep lineages of a meiobenthic harpacticoid copepod. *Mol Biol Evol* 18: 1088-1102.

- Rocha-Olivares A, Fleeger JW, Foltz DW (2004) Differential tolerance among cryptic species: a potential cause of pollutant- related reductions in genetic diversity. *Environ Toxicol Chem* 23: 2132-2137.
- Rogers AR, Harpending H (1992) Population growth makes waves in the distribution of pairwise genetic differences. *Mol Biol Evol* 9: 552-569.
- Rohlf FJ (2000) NTSYSpc version 2.1. Numerical taxonomy and multivariate analysis system. Exeter Software. Setauket.
- Rowe CL (2003) Growth responses of an estuarine fish exposed to mixed trace elements in sediments over a full life cycle. *Ecotoxicol Environ Saf* 54: 229-239.
- Rundle HD, Nagel L, Boughman JW, Schluter S (2000) Natural selection and parallel speciation in sympatric sticklebacks. *Science* 287: 306-308.
- Saccheri I, Kuussaari M, Kankare M, Vikman P, Fortelius W, Hanski I (1998) Inbreeding and extinction in a butterfly metapopulation. *Nature* 392: 491- 494.
- Sanderson MJ, Shaffer HB. 2002. Troubleshooting molecular phylogenetic analyses. *Annu Rev Ecol Syst* 33: 49-72.
- Sá-Pinto A, Branco M, Harris JD, Alexandrino P (2005) Phylogeny and phylogeography of the genus *Patella* based on mitochondrial DNA sequence data. *J Exp Mar Biol Ecol* 325: 95-110.
- SAS Institute Inc (2004) SAS OnlineDoc®9.1.3. Cary, NC: SAS Institute Inc, Cary, NC, USA.
- Scheffer M, Rinaldi S, Huisman J, Weissing (2003) Why plankton communities have no equilibrium: solutions to the paradox. *Hydrobiologia* 49: 9-18.
- Schiemer F (1982) Food dependence and energetics of free-living nematodes. I. Respiration, growth and reproduction of *Caenorhabditis briggsae* (Nematoda) at different levels of food supply. *Oecologia* 54: 108-121.
- Schizas NV, Street GT, Coull BC, Chandler GT, Quattro JM (1999) Molecular population structure of the marine benthic copepod *Microarthridion littorale* along the south eastern and Gulf coasts of the USA. *Mar Biol* 135: 399-405.
- Schizas NV, Chandler GT, Coull BC, Klosterhaus SL, Quattro JM (2001) Differential survival of three mitochondrial lineages of a marine benthic copepod exposed to a pesticide mixture. *Environ Sci Technol* 35: 535-538.

- Schizas NV, Coull BC, Chandler GT, Quattro JM (2002) Sympatry of distinct mitochondrial DNA lineages in a copepod inhabiting estuarine creeks in the south eastern USA. *Mar Biol* 140: 585-594.
- Schmidt H, Westheide W (1999) Genetic relationships (RAPD-PCR) between geographically separated populations of the 'cosmopolitan' interstitial polychaete *Hesionides gohari* (Hesionidae) and the evolutionary origin of the freshwater species *Hesionides riegerorum*. *Biol Bull* 196: 216-226.
- Schneider S, Roessli D, Excoffier L (2000) Arlequin ver. 2.000: A software for population genetics data analysis. Genetics and Biometry Laboratory, University of Geneva, Switzerland.
- Schroth W, Jarms G, Streit B, Schierwater B (2002) Speciation and phylogeography in the cosmopolitan marine moon jelly, *Aurelia* sp.. *BMC Evol Biol* 2: 1-10.
- Seberg O, Humphries CJ, Knapp S, Stevenson DW, Petersen G, Scharff N, Andersen NM (2003) Shortcuts in systematics? A commentary on DNA-based taxonomy. *Trends Ecol Evol* 18: 63-65.
- Sites JW JR, Marshall JC (2003) Delimiting species: a Renaissance issue in systematic biology. *Trends Ecol Evol* 18: 462-470.
- Sites JW JR, Marshall JC (2004) Operational criteria for delineating species. *Annu Rev Ecol Syst* 35: 199-227.
- Sivasundar A, Hey J (2005) Sampling from natural populations with RNAi reveals high outcrossing and population structure in *Caenorhabditis. elegans*. *Curr Biol* 15 (17): 1598-1602.
- Slatkin M (1977) Gene flow and genetic drift in a species subject to frequent local extinctions. *Theoret Popul Biol* 12: 253-262.
- Slatkin M (1987) Gene flow and the geographic structure of natural populations. *Science* 236: 787-792.
- Slatkin M (1993) Isolation by distance in equilibrium and non-equilibrium populations. *Evolution* 47: 264-279.
- Smith VS (2005) DNA barcoding: perspectives from a "Partnerships for Enhancing Expertise in Taxonomy" (PEET) debate. *Syst Biol* 54: 841-844.
- Sokal RR, Rohlf FJ (1997) *Biometry: the principles and practice of statistics in biological research*. Freeman, 3th edition, New York.

- Spiridonov SE, Reid AP, Podrucka K, Subbotin SA, Moens M (2004) Phylogenetic relationships within the genus *Steinernema* (Nematoda: Rhabditida) as inferred from analyses of sequences of the ITS1-5.8S-ITS2 region of rDNA and morphological features. *Nematology* 6: 547-566.
- Standing D, Knox OGG, Mullins CE, Killham KK, Wilson MJ (2006) Influence of nematodes on resource utilization by bacteria- an *in vitro* study. *Microb Ecol* 52: 444-450.
- Statsoft Inc (2000) Statistica for Windows, Tulsa, USA
- StatSoft, Inc. (2001). STATISTICA (data analysis software system), version 6. [www.statsoft.com](http://www.statsoft.com).
- Steel DJ, Trewick SA, Wallis GP (2000) Heteroplasmy of mitochondrial DNA in the Ophiuroid *Astrobrachion constrictum*. *J Hered* 91: 146-149.
- Street GT, Montagna PA (1996) Loss of genetic diversity in Harpacticoida near offshore platforms. *Mar Biol* 126: 271-282.
- Street GT, Lotufo GR, Montagna PA, Fleeger JW (1998) Reduced genetic diversity in a meiobenthic copepod exposed to a xenobiotic. *J Exp Mar Biol Ecol* 222: 93-111.
- Sturmbauer C, Opadiya GB, Niederstätter H, Riedmann A, Dallinger R (1999) Mitochondrial DNA reveals cryptic oligochaete species differing in cadmium resistance. *Mol Biol Evol* 16: 967-974.
- Suatoni E, Vicario S, Rice S, Snell T, Caccone A (2006) An analysis of species boundaries and biogeographic patterns in a cryptic species complex: The rotifer *Brachionus plicatilis*. *Mol Phylog Evol* 41: 86-98.
- Sudhaus W (1974) Nematoden (insbesondere Rhabditiden) des Strandanwurfs und ihre Beziehungen zu Krebsen. *Faun.-ökol. Mitt.* 4: 365-400.
- Sudhaus W, Nimrich M (1989) Rhabditid nematodes from seaweed deposits in Canada with a description of *Rhabditis (Pellioiditis) littorea* n. sp. *Can J Zool* 67: 1347-1352.
- Sudhaus W, Fitch D (2001) Comparative studies on the phylogeny and systematics of the Rhabditidae (Nematoda). *J Nematol* 33: 1-70.
- Sunnucks P, Wilson ACC, Beheregaray LB, Zenger K, French J, Taylor AC (2000) SSCP is not so difficult: the application and utility of single-stranded conformation polymorphism in evolutionary biology and molecular ecology. *Mol Ecol* 9: 1699-1710.

## CITED LITERATURE

---

- Sursurluk A, Dix I, Stackebrandt E, Strauch O, Wyss U, Ehlers RU (2000) Identification and ecological characterization of three entomopathogenic nematode-bacterium complexes from Turkey. *Nematology* 3: 833-841.
- Swofford DL (1998) PAUP\*. Phylogenetic Analysis Using Parsimony (\*and other methods). Version 4. Sunderland, Massachusetts: Sinauer Associates.
- Taberlet P, Fumagalli L, Wust-Saucy AG, Cosson JF (1998) Comparative phylogeography and postglacial colonisation routes in Europe. *Mol Ecol* 7: 453-464.
- Tajima F (1983) Evolutionary relationship of DNA sequences in finite populations. *Genetics* 123: 585-595.
- Tajima F (1989) Statistical method for testing the neutral mutation hypothesis by DNA polymorphism. *Genetics* 123: 585-589.
- Tamura K, Nei M (1993) Estimation of the number of nucleotide substitutions in the control region of mitochondrial DNA in humans and chimpanzees. *Mol Biol Evol* 10: 512-526.
- Tautz D, Arctander P, Minelli A, Thomas RH, Vogler AP (2003) A plea for DNA taxonomy. *Trends Ecol Evol* 18: 70-74.
- Taylor MS, Hellberg ME (2003) Genetic evidence for local retention of pelagic larvae in a Caribbean reef fish. *Science* 299: 107-109.
- Taylor MS, Hellberg ME (2005) Marine radiations at small geographic scales: speciation in neotropical reef gobies (*Elacatinus*). *Evolution* 59: 374-385.
- Templeton AR, Boerwinkle E, Sing CF (1987) A cladistic analysis of phenotypic associations with haplotypes inferred from restriction endonuclease mapping.I. Basic theory and an analysis of alcohol dehydrogenase activity in *Drosophila*. *Genetics* 117:343-351.
- Templeton AR, Sing CF (1993) A cladistic analysis of phenotypic associations with haplotypes inferred from restriction endonuclease mapping.IV. Nested analyses with cladogram uncertainty and recombination. *Genetics* 134:659-669.
- Templeton AR, Routman E, Phillips CA (1995) Separating population structure from population history: a cladistic analysis of the geographical distribution of mitochondrial DNA haplotypes in the tiger salamander, *Ambystoma tigrinum*. *Genetics* 140: 767-782.
- Templeton AR (1998) Nested clade analyses of phylogeographic data: testing hypotheses about gene flow and population history. *Mol Ecol* 7: 195-200.

- Thiel M, Gutow L (2005) The ecology of rafting in the marine environment.II. The rafting organisms and community. *Oceanogr Mar Biol Annu Rev* 43:279-418.
- Thomas RH, Hunt JA (1993) Phylogenetic relationships in *Drosophila*: a conflict between molecular and morphological data. *Mol Biol Evol* 10: 362-374.
- Thompson JD, Gibson TJ, Plewniak F, Jeanmougin F, Higgins DG (1997) The Clustal\_X windows interface: flexible strategies for multiple sequence alignment aided by quality analysis tools. *Nucleic Acids Res* 24: 4876-4882.
- Tietjen JH, Lee JJ, Rullman J, Greengart A, Trompeter J (1970) Gnotobiotic culture and physiological ecology of the marine nematode *Rhabditis marina* Bastian. *Limnol Oceanogr* 15: 535-543.
- Tietjen JH, Lee JJ (1977) Feeding behaviour of marine nematodes. In: Ecology of marine benthos. Coull BC (Ed.), University of South Carolina Press, Columbia: 22-36.
- Tigano MS, Carneiro RMDG, Jeyaprakash A, Dickson DW, Adams B (2005) Phylogeny of *Meloidogyne* spp. Based on 18S rDNA and the intergenic region of mitochondrial DNA sequences. *Nematology* 7: 851-862.
- Tilman D (1996) Biodiversity: population versus ecosystem stability. *Ecology* 77: 350-363.
- Timm RW (1956) Marine nematodes from the Bay of Bengal - I Phasmidae. *J Bombay Nat Hist Soc* 54: 87-91.
- Todaro MA, Fleeger JW, Hu YP, Hrinkevich AW, Foltz DW (1996) Are meiofaunal species cosmopolitan? Morphological and molecular analysis of *Xenotrichula intermedia* (Gastrotricha: Chaetonotida). *Mar Biol* 125: 735-742.
- Turrell WR (1992) New hypotheses concerning the circulation of the northern North Sea and its relation to North Sea fish stock recruitment. *ICES J Mar Sci* 49: 107-123.
- Ullberg J, Olafsson E (2003) Free-living marine nematodes actively choose habitat when descending from the water column. *Mar Ecol Prog Ser* 260: 141-149.
- Ullberg J (2004) Dispersal in free-living, marine, benthic nematodes: passive or active processes? PhD Dissertation, Stockholm University, Sweden. p. 27.
- Urban-Malinga B, Moens T (2006) Fate of organic matter in Arctic intertidal sediments: is utilisation by meiofauna important? *J Sea Res* 56: 239-248.

## CITED LITERATURE

---

- Vandendriessche S, Vincx M, Degraer S (2006) Floating seaweed in the neustonic environment: A case study from Belgian coastal waters. *J Sea Res* 55: 103-112.
- van Oevelen D, Soetaert K, Middelburg JJ, Herman PMJ, Moodley L, Hamels I, Moens T, Heip CHR (2006) Carbon flows through a benthic food web: integrating biomass, isotope and tracer data. *J Mar Res* 64: 453-482.
- Van Straalen NM, Timmermans MJTN (2002) Genetic variation in toxicant-stressed populations: an evaluation of the 'Genetic erosion' hypothesis. *Hum Ecol Risk Assess* 8: 983-1002.
- Vincx M (1990) Diversity of nematode communities in the Southern bight of the North Sea. *Neth J Sea Res* 25: 181-188.
- Vincx M (1996) Meiofauna in marine and freshwater sediments. In: Hall GS (Ed.), *Methods for the examination of organismal diversity in soils and sediments*, p. 187-195. New York: CAB International IUBS UNESCO.
- Vincx M, Meire P, Heip C (1990) The distribution of nematode communities in the Southern Bight of the North-Sea. *Cah Biol Mar* 31: 107-129.
- Virgilio M, Abbiati M (2004) Allozyme genotypes and tolerance to copper stress in *Hediste diversicolor* (Polychaeta: Nereididae). *Mar Pollut Bull* 49: 978-985.
- Vrain TC, Wakarchuk DA, Lévesque AC, Hamilton RI (1992) Intraspecific rDNA restriction fragment length polymorphism in the *Xiphinema americanum* group. *Fund Appl Nematol* 15: 563-573.
- Vranken G, Heip C (1983) Calculation of the intrinsic rate of natural increase,  $r_m$ , with *Rhabditis marina* Bastian 1865 (Nematoda). *Nematologica* 29: 468-477.
- Vranken G, Vanderhaeghen R, Heip C (1985) Toxicity of cadmium to free-living marine and brackish water nematodes (*Monhystera microphthalma*, *Monhystera disjuncta*, *Pellioiditis marina*). *Dis Aquat Org* 1: 49-58.
- Vranken G (1987) An autecological study of free-living marine nematodes. *Acad Anal- Meded K Acad Belg, Kl Wet* 49: 73-97.
- Vranken G, Herman PJM, Heip C (1988) Studies of life-history and energetics of marine and brackish-water nematodes. I. Demography of *Monhystera disjuncta* at different temperature and feeding conditions. *Oecologia* 77: 296-301.
- Wade M, and D McCauley (1988) Extinction and recolonisation: their effects on the genetic differentiation of local populations. *Evolution* 42: 995-1005.



- Wahlberg N, Braby MF, Brower AVZ, de Jong R, Lee M-M, Nylin S, Pierce NE, Sperling FAH, Vila R, Warren AD, Zakharov E (2005) Synergistic effects of combining morphological and molecular data in resolving the phylogeny of butterflies and skippers. *Proc R Soc B* 272: 1577-1586.
- Wall DH, Moore JC (1999) Interactions underground. Soil biodiversity, mutualism, and ecosystem processes. *Bioscience* 49: 109-117.
- Waples RS (1989) A Generalized approach for estimating effective population size from temporal changes in allele frequency. *Genetics* 121: 379-391.
- Wares JP, Cunningham CW (2001) Phylogeography and historical ecology of the North Atlantic intertidal. *Evolution* 55: 2455-2469.
- Warwick R (1987) Meiofauna: their role in marine detrital systems, p. 282-295. In: DJW Moriarty, RSV Pullin (eds.), *Detritus and microbial ecology in aquaculture*. ICLARM Conference Proceedings 14. International Center for Living Aquatic Resources Management, Manila.
- Warwick RM, Platt HM, Somerfield PJ (1998) Free-living marine nematodes Part III. Monhysterids. *Synopsis of the British fauna* 53, Dorset Press, Great Britain.
- Wetzel MA, Weber A, Giere O (2002) Re-colonisation of anoxic/sulfidic sediments by marine nematodes after experimental removal of macroalgal cover. *Mar Biol* 141: 679-689.
- Whitlock M, McCauley D (1990) Some population genetic consequences of colony formation and extinction: genetic correlations within founding groups. *Evolution* 44: 1717-1724.
- Whitlock M (1992) Nonequilibrium population structure in forked fungus beetles – Extinction, colonisation, and the genetic variance among populations. *Am Nat* 139: 952-970.
- Wiens JJ, Servedio MR (2000) Species delimitation in systematics: inferring diagnostic differences between species. *Proc R Soc Lond Ser B* 267: 631-636.
- Wiens JJ, Penkrot TA (2002) Delimiting species using DNA and morphological variation and discordant species limits in Spiny lizards (*Sceloporus*). *Syst Biol* 51: 69-91.
- Wieser W (1953) Die Beziehung zwischen Mundhöhlengestalt, Ernährungsweise und vorkommen bei freilebenden marinen Nematoden. Eine ökologische-morphologische Studie. *Ark Zool* 4: 439-484.

## CITED LITERATURE

---

- Wilke T, Pfenninger M (2002) Separating historic events from recurrent processes in cryptic species: phylogeography of mud snails (*Hydrobia* spp.). *Mol Ecol* 11: 1439-1451.
- Will KW, Mishler BD, Wheeler QD (2005) The perils of DNA barcoding and the need for integrative taxonomy. *Syst Biol* 54: 844-851.
- Williams ST, Knowlton N, Weigt LA, Jara JA (2001). Evidence for three major clades within the snapping shrimp genus *Alpheus* inferred from nuclear and mitochondrial gene sequence data. *Mol Phylogen Evol* 9: 131-140.
- Wu C-I (2001) The genic view of the process of speciation. *J Evol Biol* 14: 851-865.
- Zhu XQ, Gasser RB (1998) Single-strand conformation polymorphism (SSCP)-based mutation scanning approaches to fingerprint sequence variation in ribosomal DNA of ascaridoid nematodes. *Electrophoresis* 19: 1366-1373.
- Zhu XQ, D'Amelio S, Hu M, Paggi L, Gasser RB (2001) Electrophoretic detection of population variation within *Contraecum ogmorhini* (Nematoda: Ascaridoidea: Anisakidae). *Electrophoresis* 22: 1930-1934.
- Zhu XQ, Jacobs DE, Chilton NB, Sani RA, Cheng NABY, Gasser RB (1998) Molecular characterization of a *Toxocara* variant from cats in Kuala Lumpur, Malaysia. *Parasitology* 117: 155-164.

ISBN: 978-90-9021-740-6



9 789090 217406