

**BERICHTE AUS DEM
ZENTRUM FÜR MEERES- UND KLIMAFORSCHUNG**

Reihe E: Hydrobiologie und Fischereiwissenschaft



Nr. 2

GERD SCHRIEVER & HJALMAR THIEL

Cruise Report DISCOL 3

Sonne Cruise 77

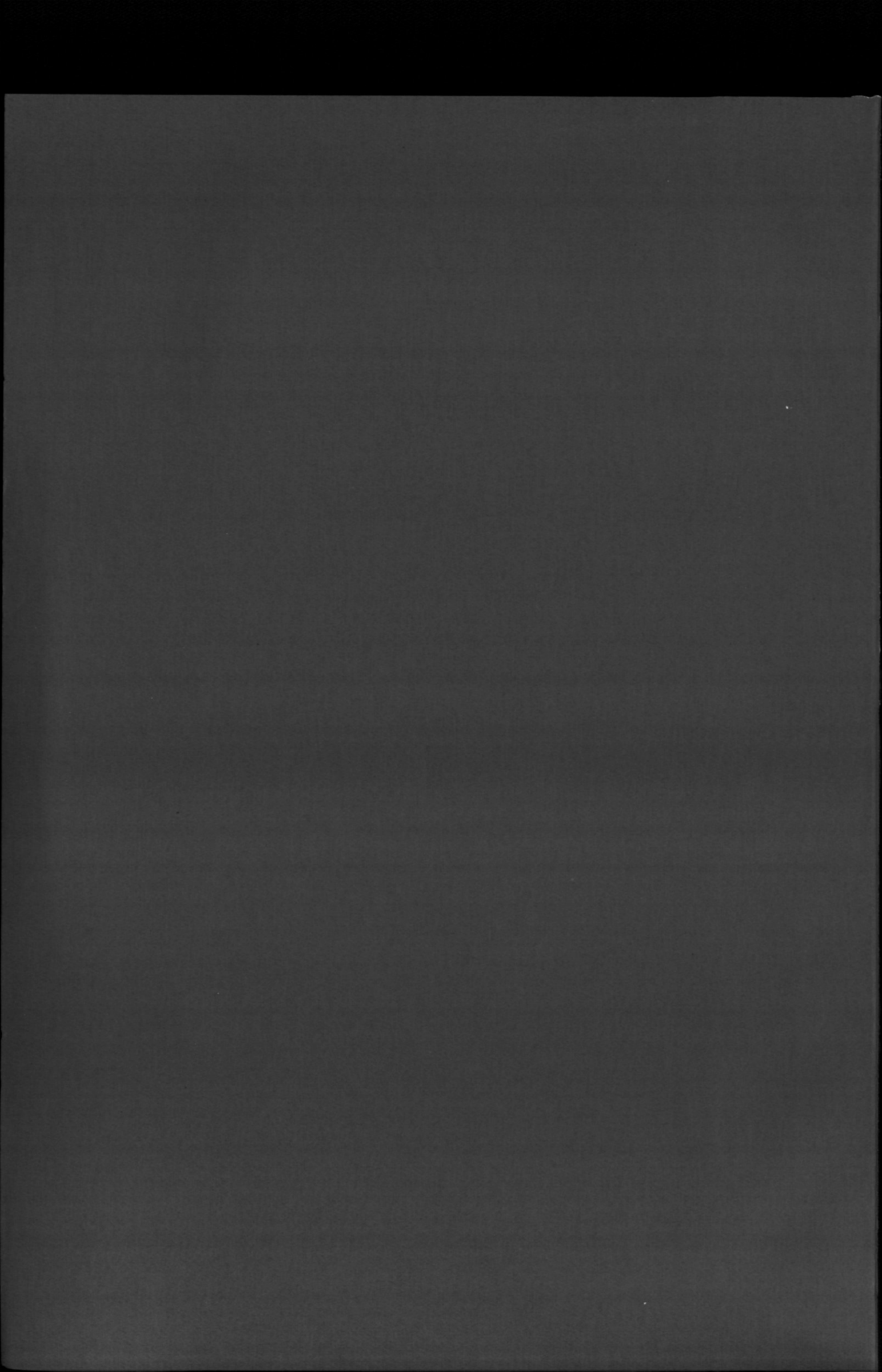

**Berichte aus dem Zentrum für Meeres- und Klimaforschung
Reihe E: Hydrobiologie und Fischereiwissenschaft**

Nr. 2

GERD SCHRIEVER & HJALMAR THIEL

Cruise Report DISCOL 3

Sonne Cruise 77

**January 26 - February 27, 1992
Balboa / Panama - Balboa / Panama**

with contributions by

**Werner Beckmann, Hartmut Bluhm, Antje Boetius
Christian Borowski, Christian Bussau
Eric Foell, Gerd Hoffmann, Caroline Maybury
Burkhard Sablotny, Peter Wagner**

**Institut für Hydrobiologie und Fischereiwissenschaft
Hamburg 1992**

Die "Berichte aus dem Zentrum für Meeres- und Klimaforschung" erscheinen in 6 Reihen mit folgendem Inhalt:

Reihe A:	Meteorologie
Reihe B:	Ozeanographie
Reihe C:	Geophysik
Reihe D:	Biogeochemie und Meereschemie
Reihe E:	Hydrobiologie und Fischereiwissenschaft
Reihe Z:	Interdisziplinäre Zentrumsberichte

Alle Beiträge sind unredigiert und geben allein die Meinung des Verfassers wieder. Sie sollen in erster Linie dem sich mit dem jeweiligen Thema befassenden Personenkreis als Arbeitsunterlagen dienen und sind oft gleichzeitig Berichte für die Institutionen, die die betreffenden Arbeiten gefördert haben.

Exemplare dieser Arbeit können bezogen werden über:

**Institut für Hydrobiologie und Fischereiwissenschaft
Zeiseweg 9
2000 Hamburg 50**

Das diesem Bericht zugrundeliegende Vorhaben wurde mit Mitteln des Bundesministers für Forschung und Technologie unter den Förderkennzeichen 03R417 und 01F0010 F gefördert. Die Verantwortung für den Inhalt dieser Veröffentlichung liegt bei den Autoren.

DISCOL-publication No. 20

ISSN 0936-949X

Zentrum für Meeres- und Klimaforschung der Universität Hamburg
Bundesstr. 55 - 2000 Hamburg 13

Contents

1. The objections of the DISCOL program and the third DISCOL cruise	1
1.1 DISCOL environmental impact studies	1
1.2 DISCOL environmental studies of commercial interest	2
1.3 DISCOL baseline studies	3
1.4 The objectives of DISCOL 3, Cruise SO 77	3
2. Short narrative of cruise SO 77	4
3. Participants and institutions	10
4. Acknowledgements	11
5. The DISCOL Experimental Area (DEA)	12
6. Equipment and methods	16
6.1 Benthos and sediment sampling	16
6.2 Benthos and chemical component subsampling	17
6.2.1 Macrofauna (C. Borowski)	17
6.2.2 Meiofauna (C. Bussau)	18
6.2.3 Nodule epi- and crevice fauna	18
6.2.4 Benthic Rhizopoda (C. Maybury)	19
6.2.5 Bacterial numbers and microbial enzymes (A. Boetius)	20
6.2.6 Chemical constituents of sediment	21
6.3 Photography and Videorecording	22
6.3.1. OFOS - Ocean Floor Observation System	22
6.3.2. FBOS - Freefall Benthos Observation System	23
6.4 Deep towed side-scan-sonar system and photography (G. Hoffmann)	23
6.5 Macroplankton and micronekton (W. Beckmann)	26
6.6 Hydrographic measurements	27
6.7 Analysis of resedimentation using x-rays (G. Schriever, B. Sablotny, P. Wagner)	28

7. Investigations conducted and preliminary results	28
7.1 Hydrographic measurements	28
7.2 The benthos	30
7.2.1 Megafauna (E. Foell & H. Bluhm)	
7.2.1.1 OFOS deployments	30
7.2.1.2 FBOS deployments	35
7.2.1.3 Trawl deployments	36
7.2.1.4 Baited trap deployments	37
7.2.2 Macrofauna (C. Borowski)	38
7.2.3 Meiofauna (C. Bussau)	39
7.2.4 Nodule epi- and crevice fauna	40
7.2.5 Rhizopoda	
7.2.5.1 Foraminiferida	40
7.2.5.2 Xenophyophorea	42
7.2.6 Bacterial numbers and microbial enzymes (A. Boetius)	42
7.2.7 Biochemical activities and chemical sediment constituents	43
7.3 Macroplankton and micronekton (W. Beckmann)	44
7.4 Side-scan-sonar (G. Hoffmann)	46
7.5 Analysis of resedimentation using x-rays	49
Included are 21 Figures and 5 Tables	
8. Literature	52
9. Appendices	54
9.1 The use of shiptime during DISCOL 1	54
9.1.1 Summary of shiptime used for various purposes	55
9.2 Complete station list	55

1. The objectives of the DISCOL program and the third DISCOL cruise

1.1 DISCOL environmental impact studies

The acronym DISCOL is derived from the full project title "DISturbance and re-COLONization experiment in a manganese nodule area of the Southeastern Pacific". In the last 20 years, international industrial and governmental consortia have been occupied with prospecting and exploration related to mining polymetallic nodules from the deep sea. There have been warnings that the environmental impacts of this industrial ocean penetration might have harmful influences on the abyssal ecosystem and biota, but research in this field remained rather limited. Pre-Pilot Mining Tests conducted in 1978-79 were monitored to some extent (AMOS et al. 1977; BURNS et al. 1980; OZTURGUT et al. 1981) and the tracks of the mining collectors on the sea bottom were investigated in 1983 (SPIESS et al. 1987). Quite a number of additional papers appeared which are based on these mining tests (e. g. BISCHOFF & PIPER (eds) 1979; the papers in Marine Mining, volume 3, number 1/2, 1981; SCHNEIDER & THIEL 1988).

Most of these papers describe oceanographic situations and processes, or try to deduce environmental impact of full scale mining from monitoring of the small scale tests and thus are rather theoretical. It is our opinion that the evaluation of full scale mining requires experiments conducted at scales that allow extrapolation to the impact of commercial mining.

Very little is known about processes in the deep sea. Although the potential for the recolonization of defaunated areas exists in the deep see (THIEL in press b), one question that arises from large scale sediment surface disturbances is that of rate in the re-establishment of the benthic community. Therefore, we proposed to conduct a large scale experiment involving the disturbance of an extended bottom area to observe its recolonization over several years, possibly for a decade or even longer.

Further impacts in the near-bottom water layer and on the seabed are those related to plume creation and sediment blanketing, respectively. This cruise did not intend to study these problems in detail, but initial sampling of plankton was commenced.

The Bundesministerium für Forschung und Technologie (BMFT) der Bundesrepublik Deutschland (Ministry of Research and Technology of the Federal Republic of Germany) has approved our DISCOL proposal for the years 1988 to 1993. The first phase of the DISCOL project included two research cruises with R. V. SONNE, the cruises SO-61 and SO-64, both of which took place within the year 1989.

1.2 DISCOL environmental studies of commercial interest

Mining consortia or companies will have to apply for mining licenses before mining can be conducted. Irrespective of whether these will be granted through national agencies or through the UN Seabed Authority, licenses will only be given under several conditions, terms and restrictions which include providing information about the environment. Therefore, a good knowledge and understanding of the baseline environmental conditions must be available. Although DISCOL does not specifically aim at the collection of relevant data, many of the results will be useful within the framework of industrial mining permits and governmental applications. For this reason, the DISCOL Experimental Area (DEA) was located in the Peru Basin of the South Pacific, near the area of a West German mining claim (Fig. 1).

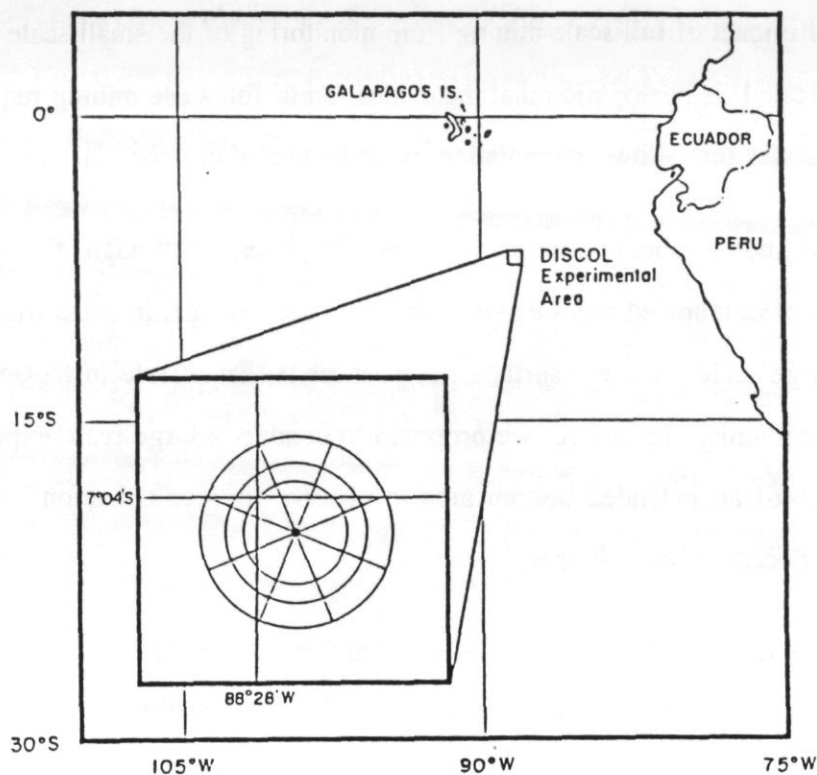

Figure 1: Location of the DISCOL Experimental Area (DEA).

1.3 DISCOL baseline studies

The primary objectives of DISCOL certainly are environmental impact studies and the entire experimental design was dictated by the requirements of environmental evaluation. However, so little is known about the deep sea that the data collected during the DISCOL cruises will also be of general interest.

Intensive and repeated studies in tropical oceanic deep-sea areas are rare. Data evaluation in the DISCOL program will give information on abyssal community structure, since at least all the ecologically important animal groups will be studied taxonomically. The collected samples will provide knowledge on the abundance of mega-, macro- and meiofauna, organic sediment components, bacterial biomass and biotic activities. This will be the first time that successional phases in the redevelopment of communities may be recognized on a large scale. Additional geological and geochemical studies as well as planktonic, physical and chemical investigations were approved by the BMFT in 1991 and 1992 and will be conducted during this and the following years. This co-ordinated program of the so-called TUSCH (Tiefsee-Umwelt-Schutz, i.e. deep-sea environmental protection) initiative would allow for the collection of long term data in a remote area, and additionally, these could be related to the international Joint Global Ocean Flux Study (JGOFS).

1.4 The objectives of DISCOL 3, Cruise SO-77

This third cruise in the DISCOL series aimed at

- conducting the third post-impact study (three years after the initial disturbance and the first post-impact, and two and half years after the second post-impact investigations),
- conducting initial zooplankton and nekton sampling within the program called ZOONEK.

2. Short narrative of cruise SO-77

R.V. SONNE left Balboa/Panama on January 26 and arrived in the DISCOL working area after 3 1/2 days, on January 31, 1992 some 400 nautical miles south of the Galapagos Islands and 480 nautical miles from the nearest coastal region in Peru.

The first and most urgent duty has been the recovery of a current meter chain with 6 current meters. This system was deployed at the end of DISCOL cruise 2 in September 1989, planned to stand at its position until the return of SONNE in the fall of 1991. Due to other cruise plans and the intensive reconstruction and modernization of the SONNE, DISCOL 3 had to be postponed for half a year. This resulted in some uncertainty whether or not the transponders in the current meter deployment would still answer on command and release itself with the current meter chain from the bottom weight. A first test was conducted on January 31 in the morning and the transponders answered but did not release the chain. In the afternoon they responded to the release command and the orange bouyancy spheres surfaced close to SONNE and were all six current meters, the two transponders and four bouyancy packages of a total of 20 spheres were safely recovered at 16.15 h. A first check up of the recordings gave evidence for proper functioning of the six current meters. Important results on currents in depths of 15, 30, 50, 100, 200 and 500 m above bottom and valuable data for the verification of current modelling are expected from these recordings.

On January 31, 1992 a multisonde cast supplied information on the density structure of the area and of sound velocity, a requirement for correct navigation with the aid of a transponder system. On February 1, four transponders were placed outside the DISCOL Experimental Area (DEA) and one in its center. After calibration, the further research program was well prepared.

Research work during this cruise was generally the same as during the cruises DISCOL 1: the baseline study before the plow-harrow impact, and the first post impact sampling, and during DISCOL 2, covering the second post impact sampling. Box corer and multiple corer samples were collected at the same five of eight, randomly selected sectors of the circular DISCOL

area in the central and the peripheral regions. Video and on command photographic recording were employed with a deep tow system, and a still camera system, in some lowerings baited in the camera's view, were employed. For sampling larger active fauna a 3m wide frame trawl and baited traps were lowered.

New equipment in the series of DISCOL cruises were the deep towed side scan sonar for imaging the 3 year old plow-harrow disturbance tracks, and the 10 m² MOCNESS (Multiple Opening/Closing Net Environmental Sensing System) net for the collection of macroplankton and nekton. Both those systems worked with good results.

The scientific program was completed on February 22 at 19.12 h. Although some electronic failure occurred, we were able to achieve the planned sampling schedule. However, the freefall benthic observation system failed to surface on February 21 and 22. The transponder navigation array was not recovered during this cruise but left in place. SONNE cruise 78 leaving Balboa on February 28, was scheduled to take samples for geochemical analyses in the DEA and this was followed by the transponder recovery on March. On February 26, 1992 at 13.35 h. R.V. SONNE was at the pier 7 in Balboa harbour.

During all the cruise the weather conditions were perfect, with steady winds between 1 and 3 Beaufort and 26-29°C day temperatures. A few rain showers were appreciated for refreshment, and they did not hinder our work on deck. Surface water temperature was 28°C.

Equator baptism

Already on February 21 with box corer 1492 arriving on deck at 20.15 h, Neptune had sent a first message to the ocean surface indicating his arrival on R.V. SONNE on one of the following days. Captain H. Bruns read the letter to the 19 cruise participants who penetrated the southern hemisphere for the first time, disturbing Neptun's realm with heavy equipment, sound sources and flash lights, extracting delicate animals and stealing secrets from the abyssal ocean. The letter's text (Fig. 2):

Ich, Neptun,
Beherrscher der Welt-
Meere bis in deren
größten Tiefen, beab-
sichtige, die Stören-
friede am Bord des
F.S. Sonne in den
nächsten Tagen persön-
lich zu besuchen!

Neptun

07° 11. 103 S

88° 27. 970 W

4.204 m.

21. Februar 1992

Südost-Pazifik

Figure 2: Neptune's letter

Me, Neptune, Emperor of the World's Oceans, down to their greatest depths, plan to personally visit the invaders from the north on board R.V. SONNE during one of the following days.

signed: Neptune

07°11.103 S
88°27.370 W
4204 m

21. February 1992
Southeast Pacific

It occurred on February 22, when all the scientific disturbance of the ocean already come to an end and RV SONNE was just about ready to secretly escape from the DEA that Triton, a delegate of Neptune and Neptune's police unexpectedly appeared on SONNE. The 19 unbaptized southern ocean penetrators were searched for in all corners of the ship and driven together on deck, the former center of ocean disturbance activities. Triton (Fig. 3) announced that a visite of Neptune, his wife Thetis as well as the baptism of the victims would occur on the following day. He took over command of the ship from Captain Bruns. Before Triton left the ship again, the unbaptized, bunched together (Fig. 4) under a wide-meshed cargo net, received a first splash of ocean water from all available hoses on deck.

Neptune and Thetis, together with their associates and followers, arrived soon after breakfast. Again, those to be baptized were assembled under the command of the Neptune Police, and they were imprisoned after Neptune and the priest had warned them to be patient and to have their last will with them. All the new initiates were individually guided out on deck during the following hours and were baptized by the priest. They had to kiss Thetys's feet (Fig. 5), received a thorough body examination and check up by the doctor and his nurse and passed a barber shop to receive a hair styling appropriate for Neptune's realm. After two more treatments an ocean dip in a net cage ended the wholely procedure although some particularly obstinate new initiates had to pass through several stations of the baptizing ceremony again (Fig. 6). The event came to an end with the unexpected renewed baptism of the first steward and the senior scientist. After some six hours, Neptune and Thetys together with their entonage disappeared.

The day concluded with dinner and a party on deck during which baptism certificates were distributed to the newly initiated among the crew and the scientific party.



Figure 3: Triton announces the visite of Neptune and took over command of the ship from Captain Bruns.



Figure 4: The 19 unbaptized bunched together under a wide-meshed cargo net.



Figure 5: A new initiate kissing They's feet.



Figure 6: Some qualified for a special treatment

3. Participants and institutions

Beckmann, Werner, IHF - Plankton
Bloemeke, Brunhilde, IHF
Bluhm, Hartmut, IHF
Borowski, Christian, IHF
Boetius, Antje, IHF
Bussau, Christian, IHF and ZMK
Foell, Eric, NOAA
Groß, Onno, IHF
Gottwald, Ingeborg, IHF
Hoffmann, Gerd, IHF
Knickmeier, Katrin, IHF
Lu, Lin, SOA
May, Holger, BSH
Maybury, Caroline, UCW/IOS DL
Philipps, Kathrin, IHF
Sablorny, Burkhard, IHF
Schott, Thorsten, GECON, Kiel
Schriever, Gerd, IHF, chief scientist
Thiel, Hjalmar, IHF
Velten, Roswitha, IHF
Vopel, Kay, BUR
Wilhelmsen, Ute, IHF

IHF = Institut für Hydrobiologie und Fischereiwissenschaft der
Universität Hamburg, Hamburg, FRG

BSH = Bundesamt für Seeschifffahrt und Hydrographie, Hamburg, FRG

NOAA = National Oceanic and Atmospheric Administration, Washington, DC,
USA

UCW = Institute of Earth Studies, University College of Wales, Aberystwyth, GB

GECON = Geophysik Consulting, Kiel-Kronshagen, FRG

SOA = State Oceanic Administration, P.R. China

BUR = Fachbereich Biologie der Universität Rostock, Rostock, FRG

ZMK = Zoologisches Institut und Museum der Universität Kiel, FRG

4. Acknowledgements

Cruise DISCOL 3 very well achieved its goals and this is due to Captain H. Bruns and to all members of the ships crew and the scientific participants. In splendid spirit all cooperated from the first to the last minute.

We thankfully appreciate the enthusiastic help of our foreign friends during this cruise and their funding through national organizations. The British Natural Environment Research Council (NERC) for funding Dr. C. Maybury and her DISCOL-project "The impact of simulated manganese nodule mining on deep sea foraminiferal communities: a contribution to the German DISCOL project", the Chinese State Ocean Administration (SOA) for sending Mr. L. Lu for participation, and the United States National Oceanic and Atmospheric Administration (NOAA) for supporting E. J. Foell.

We are most grateful for the support the DISCOL project has received from all on board SONNE during these four, short-living weeks.

We would like to extend our appreciation to Dr. F. Werner, Geologisch-Paläontologisches Institut University of Kiel, who made available the side-scan-sonar for mapping the DISCOL Experiment Area. Dr. E. Mittelstaedt and Mr. H. May of the Bundesamt für Seeschifffahrt und Hydrographie kindly supported the project by deploying a current meter chain for 30 months between DISCOL 2 and 3 and by analyzing the recorded information.

Many thanks are also due to Dr. J. Christy, Dr. H. and I. Guzman of the Smithsonian Tropical Laboratory at Balboa/Panama who provided the possibility of x-raying sediment cores upon our return to Panama. With great patience, the Guzmans explored optimal exposure times and spent much effort on x-ray film development. They helped with considerable success in making the thickness of the blanketing sediment layer visible.

DISCOL is funded by the FRG Bundesministerium für Forschung und Technologie under contract Numbers 03-R-417 and 01-F-00010 F.

5. The DISCOL Experimental Area (DEA)

The DEA is circular with a diameter of 2nmi or 3700m, corresponding to an area of 3.14nmi² or 10,8km². The central position is 07°04.4 'S and 88°27.6'W. Water depth according to the bathymetric Hydrosweep chart (20m contour intervals) ranges from <4140m to >4170m with most of the area between 4140m and 4160m (Fig. 7).

A circular experimental area was chosen because disturbance of the area could best be achieved. Even with precise navigational aids, it would not have been possible to place the tracks of a disturber closely aside each other. However, a circular experimental area, disturbed on diametrical courses should provide a central, highly disturbed and a peripheral, less disturbed area. For sampling purposes, the experimental area was subdivided into eight pie shaped sectors, facing the main geographical directions (Fig. 7). Additionally, the area was subdivided by concentric circles, with the inner line having a radius of 1000m and a second line at a radius of 1350m, leaving a width of 500m for the outer ring area. Sampling was planned to be conducted in the central circular area and in the outer ring, representing the areas likely to be most and least disturbed by the diametric traverses, respectively. The inner ring area was not to be sampled in order to concentrate all collections centrally or peripherally. For navigational reasons, sampling positions were located on a midline in each sector, 500m and 1600m away from the center. Due to time constraints, all the sectors could not be examined equally well. Therefore, sample distribution and sequence of sampling were randomly selected with equal numbers of samples in five central and five peripheral sectors (see Fig. 7).

This rather formal sampling scheme was first applied during DISCOL 1 for the pre-impact and the first post-impact studies, and it was repeated during DISCOL 2 and during DISCOL 3. Sampling positions were rather exact due to transponder navigation. Figure 8 and 9 present the positions of all box corer and multiple corer stations within the DEA.

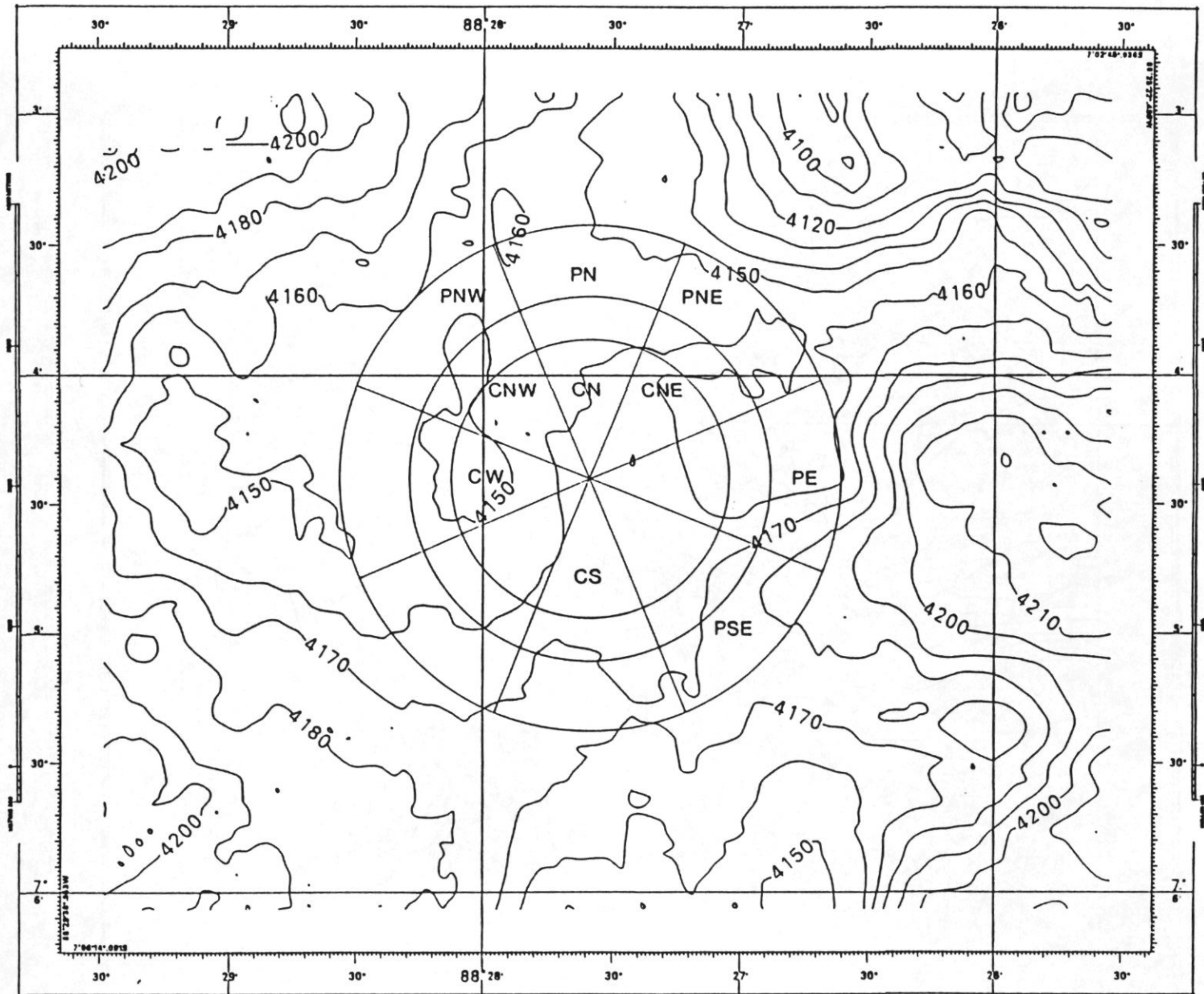

Figure 7: Bathymetric Hydrosweep chart with the five central and five peripheral sampling positions.

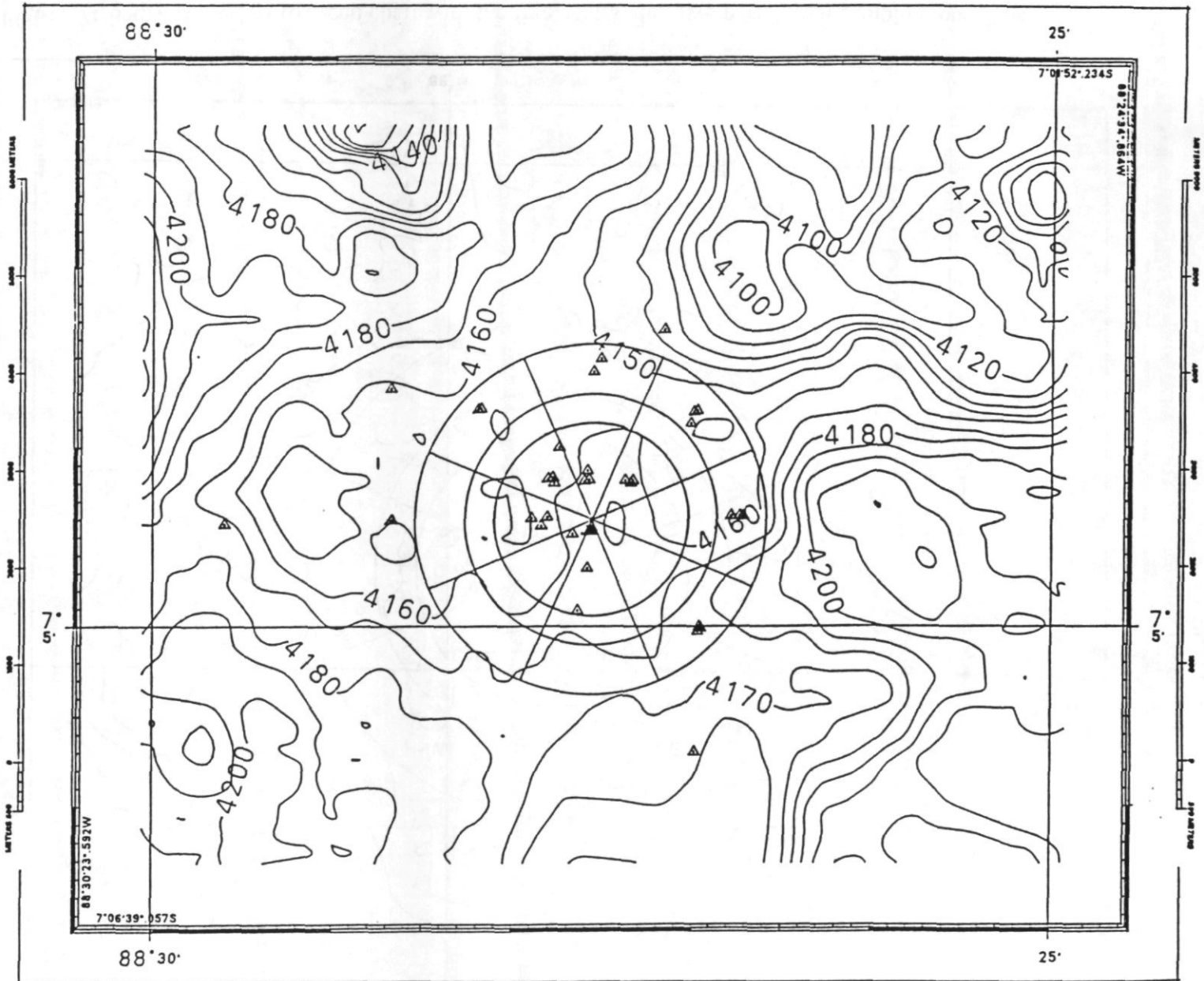

Figure 8: All box-corer stations of DISCOL 3

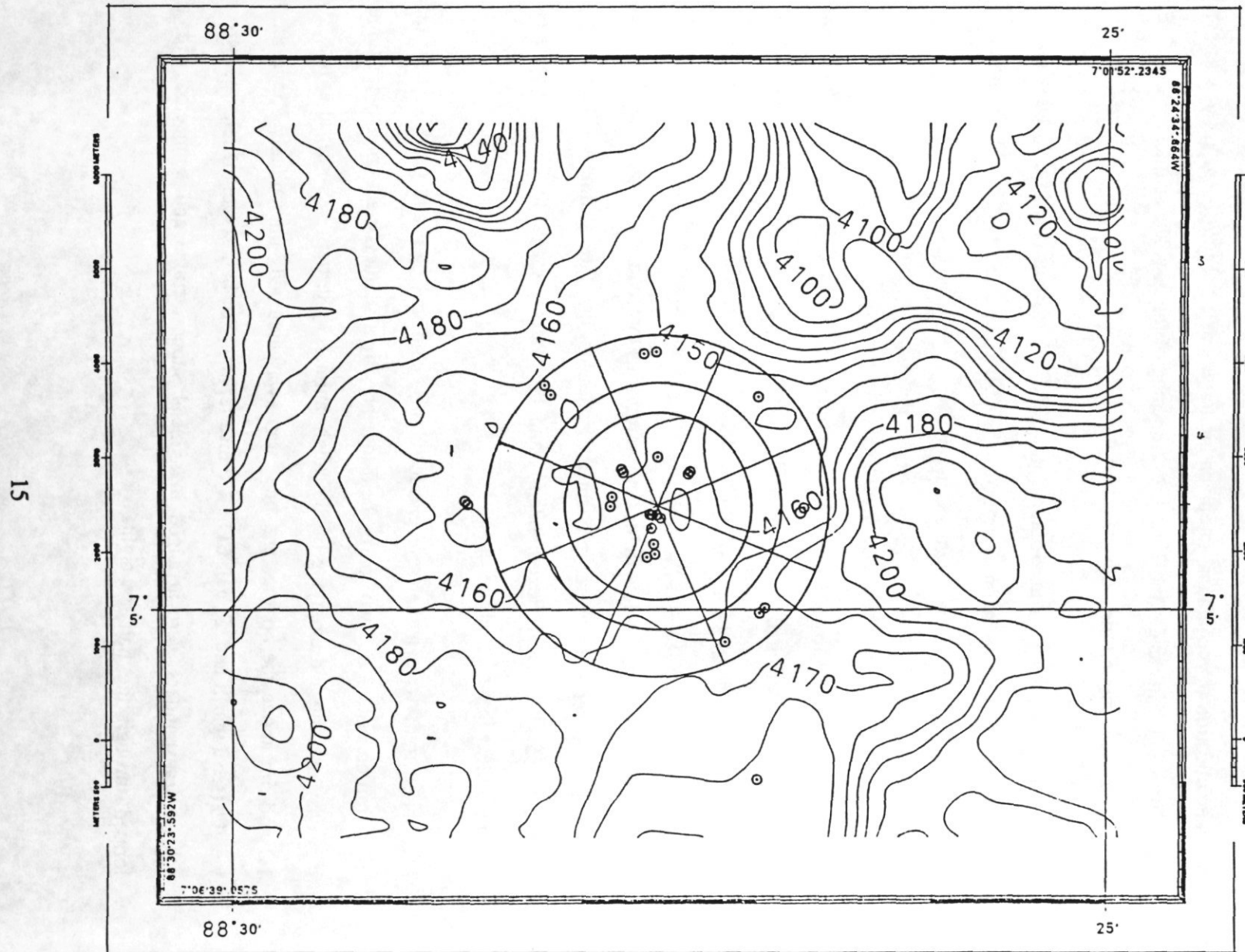

Figure 9: All multiple corer stations of DISCOL 3

6. Equipment and methods

6.1 Benthos and sediment sampling

The benthos was sampled with the standard equipment previously used in DISCOL 1 (see Thiel and Schriever, 1989).

For the collection of megafauna an epibenthic trawl was employed. The trawl was equipped with 0.3m wide skids aside the 2.3m broad opening of the net. The sediment in the DEA has a high water content and the skids sank into it.

For quantitative sampling of macrofauna, the USNEL box corer (see Fig. 6, DISCOL 1 cruise report) was used in the version described in FLEEGER et al. (1988). The sampling area is 50 x 50cm. For sample treatment see 6.2.1.

Samples for meiofauna, bacteria, microbial enzymes and the determination of chemical components were collected with the multiple corer (BARNETT et al. 1984), deviating, however, from the original type with its 12 narrower tubes. We modified the collection head to carry only 8 tubes (see Fig. 7, DISCOL 1 cruise report) with an inner diameter of 9.5cm, i. e. 70.8cm². This was thought to be necessary to increase the chance of coring undisturbed samples in a manganese nodule field. Only rarely was the coverage of polymetallic nodules so high that the corer tubes were prevented from entering the sediment. Penetration of the tubes was 35 - 40cm (length 62cm), and the water trapped above the sediment core remained clear in almost all instances.

The baited traps were made from plastic tubing 0.8m in length and 0.3m inner diameter. Each trap consisted of two parts held together by a stainless steel collar with three hooks for easy opening and emptying of the caught animals. The traps were set at 100, 50, 30, 10 and 5m above the bottom, and one trap was mounted immediately above the bottom weight (see Figs. 8 and 9, DISCOL 1 cruise report). For ballast weight release, two tandem release transponders were arranged in a metal support frame and connected with a chain looped through the ballast weight.

One of the trap chains (RK 107) represented a near total loss. The chain was found floating at the surface nearly 10 nmi from its original deployment site and had obviously been prematurely released in response to an as yet unknown stimulus or stray sound command. Although the buoyancy floatation spheres and release transponder were recovered, all six traps were lost due to having abraded and cut their way through the wire rope attaching them to the chain. Future sets should always be made with a shackle at both ends of the wire rope connecting cable to prevent repeat occurrences.

In another deployment (RK 108), the 50m trap was recovered open and empty when two latches apparently failed and allowed the trap to separate into two halves hinged by the single remaining latch.

6.2 Benthos and chemical component subsampling

6.2.1 Macrofauna (Christian Borowski)

Macrofauna samples were taken with a modified USNEL box corer with a sampling area of 50 by 50 cm (0.25 m²). As in the previous DISCOL cruises, ten subareas of the DEA, chosen randomly during DISCOL 1, were sampled three times each. Ten samples were taken 3.2 nautical miles south of the center of the DEA. This locality is considered to be uninfluenced by the disturbance of the DISCOL-experiment and was chosen as a reference area which had already been sampled during DISCOL 2. Five more box corer deployments were carried out in an area within the DEA where sidescan sonar charts revealed a high density of plow harrow tracks. Two deployments outside of the DEA were used for meiofauna sampling, two more were unsuccessful and three had to be repeated because of positioning. In total 52, box corer deployments were made.

The samples were treated as follows: The surface water was siphoned off through a 250 μ m sieve to retain upwhirled animals. Manganese nodules were taken out of the cores and adhering sediments were rinsed off and caught up on a sieve. The sediments of the cores were subdivided into depth layers of 0-2 cm, 2-5 cm and 5-10 cm, starting from the sediment

surface. The sieve residues were preserved in a borax buffered 4% formalin seawater solution. Because of the extremely low density of animals in sediments deeper than 10 cm, as the samples from the former DISCOL cruises had shown, these depths were not taken into consideration.

The 250 μm meshsize was used for all processed sediment layers instead of the 1000 μm and 500 μm screens used during DISCOL 1 and DISCOL 2. The samples of the former cruises have shown that most of the animals belonging to the "target taxa" within the macrofauna e.g. the Polychaeta, Isopoda and Tanaidacea are very small. Most of them pass through the 1000 μm screen and the quantitative yield of the 500 μm screen for these animals is not yet proven. Using a finer meshsize will verify the effectiveness of the previous sampling and will gain additional information on the size structure of these taxa. Later splitting of the samples in the laboratory into different size fractions according to the previously used meshsizes will guarantee the comparability of the sample sets from the different cruises.

6.2.2 Meiofauna (Christian Bussau)

Subsamples for meiofauna were taken from the multicorer. They were isolated as layers from each core tube: 0-1, 1-2 cm layer (subsample volume 70,8 cm^3), 2-4, 4-6 cm layer (subsample volume 142 cm^3). Immediately after subsampling from the core tubes, the material was preserved in 4% formaldehyde-seawater solution.

6.2.3 Nodule epi- and crevice fauna

Together with the Rhizopoda, metazoa occur on the nodule surface. They were collected by careful inspection with low power magnification, scraping them from their substrate or breaking off subnodules or pieces of them. The material was preserved in 4% formaldehyde-seawater solution.

While breaking up some of the nodules during inspection for epifauna on DISCOL 1, a crevice-fauna was discovered, living in sediment-filled crevices and paths between the subnodules (Fig. 8 in Cruise Report DISCOL 2, SCHRIEVER 1990). This faunal component

was searched for with low power magnification. Some nodules were carefully washed from adhering sediments, broken into small pieces and gently washed in filtered seawater. This was decanted several times to separate meiofauna and light sediment particles from nodule debris. The material was preserved in 4% formaldehyde-seawater solution for later inspection. Tanaidacea were transferred to 70% ethyl alcohol after a few days for final preservation. Some nodules were preserved in total.

6.2.4 Benthic Rhizopoda

Foraminiferida

Instead of taking syringe subsamples, as in the previous two DISCOL cruises, complete core layers were cut from 21 multiple core sets (MC 339-349, 351, 353, 355, 357-359, 361-362, 364-365). The reasons for this were threefold: first, syringe subsamples (3.46cm² cross-sectional area) did not yield representative live foraminiferal populations. Second, ice crystals break the tests of fragile agglutinated foraminifera and third, the particle size distribution of the sediments (to be measured subsequently) is altered by freezing. This departure from the sampling routine established in the former DISCOL cruises was facilitated by a new core cutting device comprising a graduated plexi-glass tube - for measuring and retaining sediments - of the same dimensions as the multiple corer's tubes and a thin metal plate - for cutting and sealing off successive layers of sediment. The fluid sediments in the top 6cm of the multiple core could be cut successfully by this device as it allowed for them to be extruded 1cm at a time and remain encapsulated by the tube and metal plate until transferred into a storage bottle. All sediment samples were fixed with 4% formaldehyde/filtered seawater buffered with borax (pH 8.2).

From each of the 10 sampling sectors within the DEA and one reference sampling station outside the DEA, one core was sectioned horizontally down to 20cm. All replicate cores were sectioned down to 6cm. The vertical, spatial and temporal distribution of the Foraminiferida within the DEA will be evaluated from this material, with special reference to core sets: MC 357, 361-362 and 364, which showed evidence of disturbance.

Xenophyophoria

The sampling techniques described by Watson in the DISCOL 1 Cruise Report (Thiel & Schriever 1989, pp. 20-21), remained the same, except that a photographic record was made of every specimen, in addition to notes and photographs of its assumed life position. This was to facilitate reconstruction of specimens should any become damaged during transit.

6.2.5 Bacterial numbers and microbial enzymes (Antje Boetius)

Subsamples for the enumeration of bacteria were collected from multiple corer samples, following the protocols of the two previous DISCOL cruises. Three parallels with one ml of sediment from each 2-cm layer down to 20 cm were fixed in a sterile filtered 2% formaldehyde/seawater solution in a total volume of 10 ml. The samples will be analysed in the home laboratory by epifluorescence microscopy with acridine orange, following the method of VELJI & ALBRIGHT 1985.

Four parallels for the determination of sediment water content were taken from the same samples with 20 ml cut-off syringes and deep frozen for further analysis.

Intact sediment cores from 2 multiple corers sampled at a station south of the DEA were incubated at 5°C during a shipboard experiment. 14 Corer samples were disturbed by mixing the top 10 cm with 10 cm of overlying bottom contact water. Samples for extracellular enzym activity, protein content, phospholipid determination (FINDLAY et al. 1990), bacterial numbers and sediment water content were taken every 1-2 days during 3 weeks. Each cm layer from a corer tube was mixed before subsampling to avoid high variation due to small scale patchiness. The cores were analysed to a depth of 10 cm. The activity of extracellular esterases was determined by measuring the hydrolysis rate of flouresceindiacetate after a method of MEYER-REIL (1991).

Four different methylumbelliferyl substrates for different hydrolytic enzymes were tested with 3 different samples from the DISCOL area to gain further information on the microbial activity of this region.

6.2.6 Chemical constituents of the sediment

Preservation of subcores through deep freezing has been unavoidable because the very soft and watery sediment could be sliced only in a frozen condition. For freezing the syringes with the subsamples were placed into a -80°C freezing box for at least 1 hour. The shortcoming of this method is the distortion of the subcore from the outer mantle layers to the inner core through freezing, shifting the central parts between layers (FLEEGER et al. 1988).

Most of the chemical determinations were conducted on board the ship because, even during deep frozen storage, organic components and activities may degrade. Additionally, deep frozen transport of all samples from Panama back to Hamburg would have been expensive and rather risky, although some of the samples, e. g. for water content and sediment dry weight analyses requiring careful weighing, had to be send back under deep frozen conditions.

The information on further procedures is summarized in Table 1.

Table 1. Methods used in the determination of chemical component concentrations.

	Syringe diameter in cm	Sample volume in cm^3	Preservation in	Method of determination	laboratory ship/home
Energy charge	1	3.14	deep freezer	Luminescence-spectrophotometry	ship
Electron transport system activity	1	0.78	deep freezer	Spectrophotometry	ship
Protein	1	0.78	deep freezer	Spectrophotometry	ship/home
Desribonucleicacid	1	3.14	deep freezer	Fluoreszenz photometry	home
Chloroplastic pigment equivalents	1	0.78	deep freezer	Fluorescens-photometry	ship
Sediment water content	1	0.78	deep freezer	weighing	home
Sediment dry weight	1	0.78	deep freezer	calculation	home

The methods are described in THIEL et al. (1987), except for the DNA method.

6.3 Photography and Videorecording

6.3.1 The Ocean Floor Observation System (OFOS)

The large OFOS instrument package utilized during prior DISCOL cruises had been lost during a recent geologically oriented expedition and was therefore unavailable for our use. While a replacement is in the process of being constructed, a smaller OFOS package termed EXPLOS (Exploration System) was made available for use during DISCOL 3 (Figure 10).

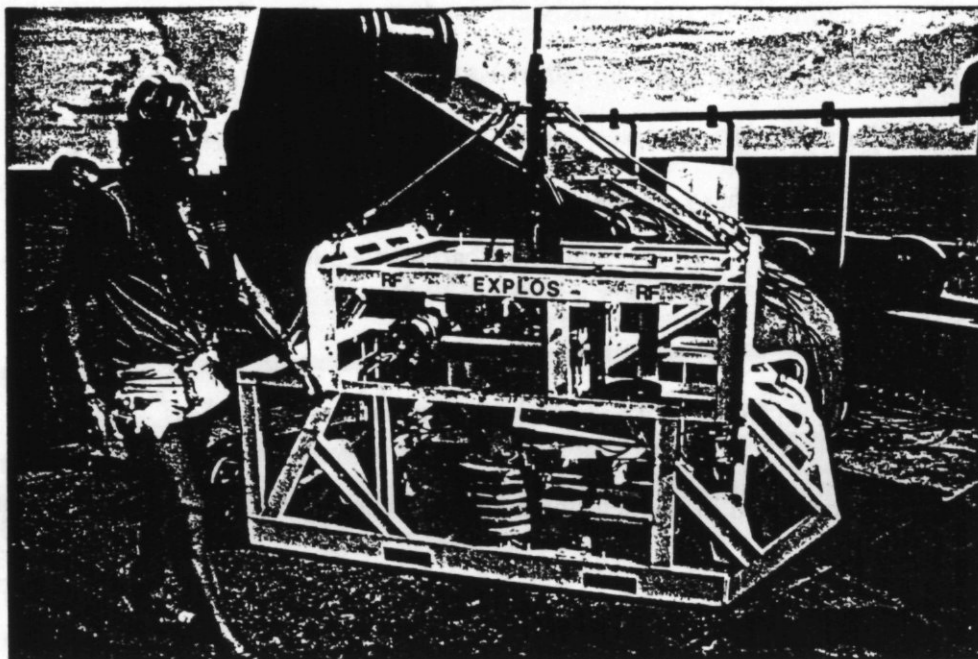

Fig. 10: The EXPLOS/OFOS package

The EXPLOS/OFOS package carries two PHOTOSEA 5000 35mm still cameras for stereo photography, although only one camera was loaded into its housing during several OFOS deployments (OFOS 26-28 and 33). Two PHOTOSEA 3000 SX strobe lights mounted on either side of the television camera provided the necessary light for the photo exposures made in a photo-on-command mode of operation. Both still cameras were mounted in parallel and were aimed vertically downward. As in prior DISCOL cruises, 30 m of KODAK Ektachrome film (ASA 200) were utilized providing up to 800 images per deployment and camera.

The video signal was generated by an OSPREY SIT video camera (type OE 0111-6006). Up to three halogen lamps were available for use and could be remotely controlled so that one inside lamp, two outside lamps, or all three lamps were on and in use at any given time. A compass mounted within a finned housing was suspended 3.4 m beneath the EXPLOS and attempts were made to obtain most photographs within the ideal focus range (3 - 4 m above the seabed).

6.3.2 The Freefall Benthos Observation System (FBOS)

The FBOS is a stainless steel 2 m high tetrapod with 35 mm Benthos survey camera, strobe, battery pack, data chamber encoder, tandem-release transponders and glass vacuum spheres for buoyancy. The ballast weight (a railroad wheel) was placed below the tetrapod frame. The camera was equipped with 30 m film length for 800 pictures and was deployed at different locations outside the DEA.

6.4. Deep towed side scan sonar and photography (Gerd Hoffmann)

Scientific objectives

Mapping of the plow-harrow tracks in the Discol Experimental Area (DEA), produced during cruise SO 61 (Discol 1) in February 1989, was the main interest of the side-scan sonar survey on this cruise. With the information regarding the level of disturbance it should be possible to discern intensely from scarcely disturbed surface layers. Hence it should facilitate obtaining disturbed or undisturbed samples within or beside of the plow-harrow tracks.

A second objective of this cruise was to test an integrated method of sonar and optical recording of the sea bottom. For this purpose a photo camera and a flash were installed on the depressor.

Techniques

Side-scan sonar survey techniques complimented by simultaneous photography were applied during the survey in the DEA. The EG&G model 990 S side-scan sonar apparatus of Kiel University was employed, equipped with two 59 kHz transducers. Additionally, the side-scan sonar module was equipped with several sensors, allowing the recording of bearing, depths, and water temperature data.

In the deep-tow array, the side-scan sonar apparatus (sonar equipment) is attached to a positive buoyancy body which is maintained at proper water depth by a separate 900 kg depressor (Fig. 11). This is equipped with a 35mm photo camera (BENTHOS Deep Sea Standard Camera System, Model 372) and a flash (BENTHOS flash, Model 382). The deep-tow array allows towing of the "fish" close to the bottom, while the effects of surface waves are considerable dampened. The winch is operated by a remote control panel next to the side-scan sonar recorder unit on RV "SONNE", allowing quick response to sea floor morphology changes detected by the shipboard HYDROSWEEP SYSTEM.

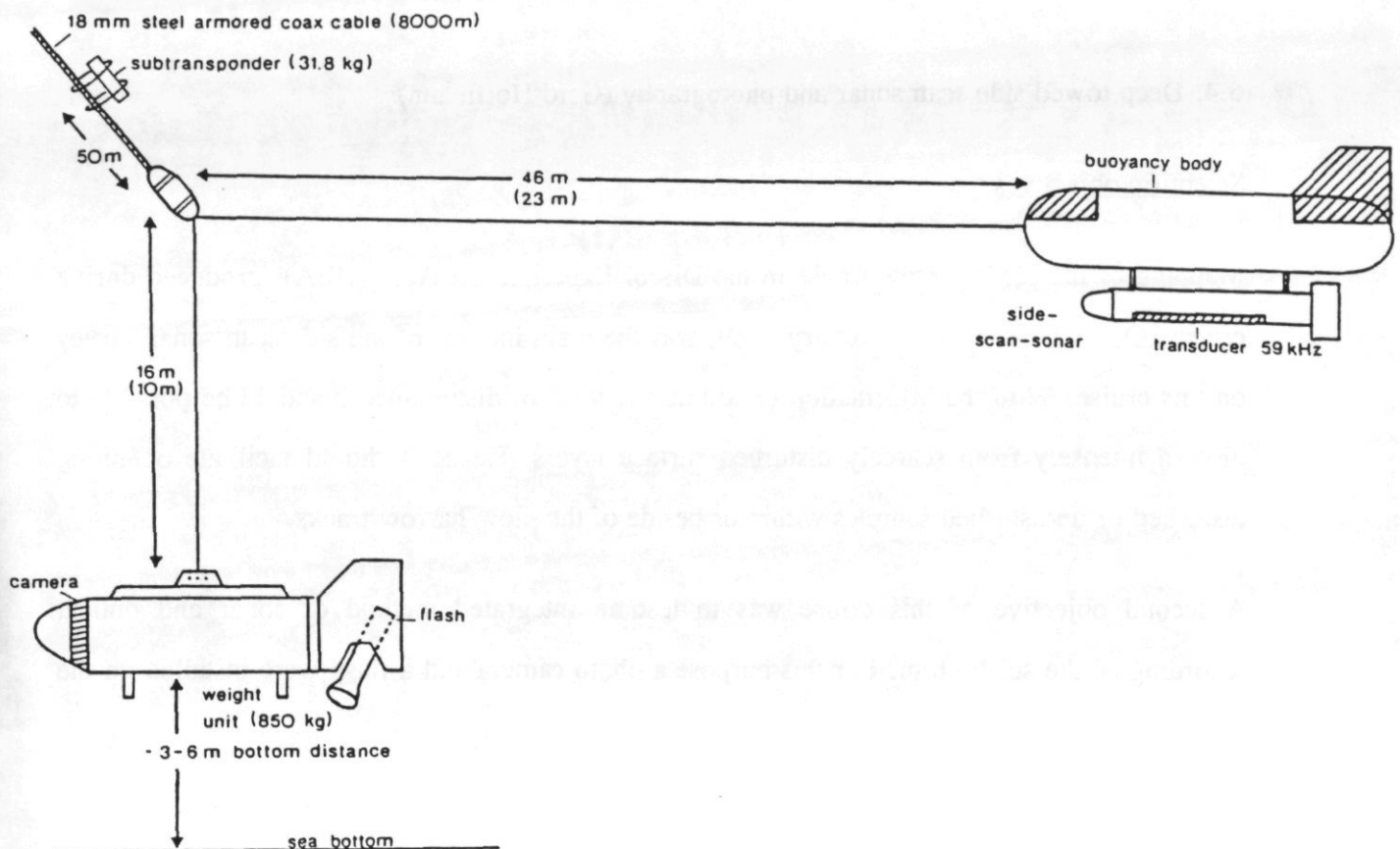

Figure 11: The side-scan sonar equipment

The sonar equipment was towed with a shipboard HATLAPA winch system. The winch system on RV "SONNE" is equipped with a 8,000 m of steel-armored coax cable. In the DEA survey tracks, with water depths of about 4150 m, a maximum of 7,350 m cable lengths was needed to maintain for a bottom distance of the side-scan-unit of between 20 and 25 m, while recording a total horizontal range of 300 m. The tracks were run with a speed over ground of approximately 2 kn. Before the beginning of the side-scan sonar tracks, a 1:50,000 bathymetrical map was created by the HYDROSWEEP SYSTEM.

The side-scan sonar simultaneous photography technique was used the first time on a German research vessel. Photo camera and flash in the weight unit were arranged for photography of the sea bottom at a distance of about 3 to 5 m. The photography without side-scan sonar was successfully tested (in shallow water) before this cruise in the Baltic Sea.

The only information regarding the bottom distance of the depressor is indirect information from the bottom distance of the side-scan sonar equipment, following the depressor unit at 46 m (transects SO 77. DT 1 - 4), or 23 m (transects SO 77. DT 5 - 8) respectively. As a result of the experience with another weight unit in this towing configuration, it was estimated that the sonar equipment have approximately the same depth as the connection point of the depressor and side-scan sonar units (Fig. 11). Hence a cable length of 16 m was chosen between connection point and depressor unit, allowing a bottom distance for the equipment of 19 to 21 m. During depressor track SO 77. DT 8 the cable length between connection point and the depressor was reduced to 10 m.

Photo camera and flash were triggered with a delay of 150 to 200 minutes and a photo interval of 10 to 15 sec.. The film had 800 exposures, hence the photo camera was active for 2-3 hours.

The photo-tracks were planned this way since it was anticipated that after a delay of about 3 hours the side-scan sonar and the depressor should be in a stable equilibrium close to the sea bottom. At this moment, the recording units were about 0.5 mile away from entering the DEA. Hence photos should be taken before, in and after the DEA.

During tracks of SO 77. DT 2 - 8, the shipboard SONARTECH - II - ACOUSTIC NAVIGATION SYSTEM was successfully used (Fig. 18). In this SONARTECH transponder system, an EG&G SEA LINK SYSTEM 723A (31.8 kg) as subtransponder was attached 50 m above the connection point of depressor and side-scan unit. Using this transponder array we reached a positioning accuracy of about 5 m, as demonstrated by the repetition of a transect (SO 77. DT 2 and 5).

6.5 Macroplankton and Micronekton (W. Beckmann)

The Deep Scattering Layer was recorded over several periods of time with an ELAC-Echosounder at a frequency of 20 kHz.

Sampling of zooplankton and micronekton was carried out with a 10 m² -MOCNESS (Multiple Opening/Closing Net Environmental Sensing System). The system carried five nets (mesh size 1800 μ m), which were sequentially opened and closed via conducting cable. To stabilize the MOCNESS, it was launched to the maximum depth with the first net open. The other four nets served for stratified oblique sampling of different water column layers during hauling. In each of these four nets, a smaller plankton net with an opening of 30 cm diameter and a mesh size of 335 μ m was installed to obtain some qualitative information on the smaller organisms that larger zooplankton and micronekton may feed on.

Samples were preserved in a 4-6 % formaldehyde-seawater solution buffered with borax. Six successful hauls were conducted yielding 24 stratified samples, and in addition 24 samples from the small nets. Some relevant station data and sampling depths are listed in Table 2 (page 28). Integrated samples collected during hauling are not listed. Some of them contained large numbers of gelatinous animals and were only preserved qualitatively after sorting out larger fish and crustaceans.

Table 2: Station list. Times of sampling and latitude/longitude data refer to the time from opening net 2 until closing net 5.

Haul No.	Ship's Station	Date	Station Time total	Sampling Time	Position		Depths of Sampling/dbar
					Lat. S	Long. W	
1	43	06. 02.	10.30-12.53	11.38-12.24	07°05.6/88°27.0 - 07°08.2/88°25.1		750 - 600 600 - 450 450 - 400 400 - 350
2	70	11/12. 02.	22.05-00.48	23.20-00.01	07°03.6/88°27.6 - 07°03.2/88°27.7		1450 - 1250 1250 - 1050 1050 - 900 900 - 750
3	90	14. 02.	10.33-11.00	Malfunction of cable, station ceased			
4	101	15. 02.	13.44-15.05	14.21-14.43	07°04.6/88°29.8 - 07°04.5/88°29.2		500 - 450 450 - 400 400 - 350 350 - 300
5	106	16. 02.	10.30-13.30	12.04-12.45	07°05.4/88°25.8 - 07°06.0/88°24.5		1450 - 1250 1250 - 1050 1050 - 900 900 - 750
6	118	17. 02.	20.47-22.30	21.29-22.13	07°05.2/88°30.5 - 07°06.1/88°29.6		750 - 600 600 - 450 450 - 400 400 - 350
7	143	21. 02.	12.43-17.07	14.44-16.00	07°07.2/88°29.5 - 07°09.4/88°28.8		2050 - 1850 1850 - 1650 1650 - 1450 1450 - 1250

6.6 Hydrographic measurements

Two hydrographic casts were conducted with the rosette water sampler and CTD. The first one was necessary for the calculation of sound velocity to aid the transponder navigation, the second one was lowered for a technical test of the new multisonde. In both instances the collected water was used for the determination of oxygen concentrations at several depths in the water column.

A current meter chain with the instruments (Anderaa) at 5, 15, 50, 100, 200 and 500 m above bottom was successfully recovered from the DEA. It had been deployed in September 1989 at the end of DISCOL 2.

6.7 Analysis of resedimentation using x-rays (G. Schriever, B. Sablotny, P. Wagner)

The method used to image a resettled sediment layer was described in detail by Kukert (1990). Since no x-ray apparatus was available on board of RV SONNE, we contacted the Smithsonian Tropical Laboratory at Balbao/Panama and received an offer for help in getting these analyses done.

Based on our experiences with this system during DISCOL 2 we constructed rectangular coring tubes to obtain samples for x-raying (fig 12, page 29). These were supported by the upper portions of normal cylindrical corer tubes for purposes of mounting them in the multicorer. The sealed rectangular cores were stabilized in a special box, kept cool on board RV SONNE, and were carefully transported by car from the harbor to the laboratory in Balboa. Eight of the nine tubes were successfully transferred with the sediment layers remaining undisturbed.

7. Investigations conducted and preliminary results

7.1 Hydrographic measurements

The results of the CTD casts including those on oxygen concentration show only minor differences to those met during DISCOL 1.

The current recordings were processed preliminarily. The current meters registered data for different periods of time:

at 5 m
15 m
50 m
100 m
200 m
500 m

Together with the data collected between DISCOL 1 and 2 information on the currents is now available from the different depths for periods between 6 and 28 months. A first rough analysis verifies earlier results of predominantly northerly transport with velocities up to 17 cm/sec. So far no specific events were discovered in the recordings.

Figure 12: Blue print for the new constructed rectangular core to obtain samples for x-raying.

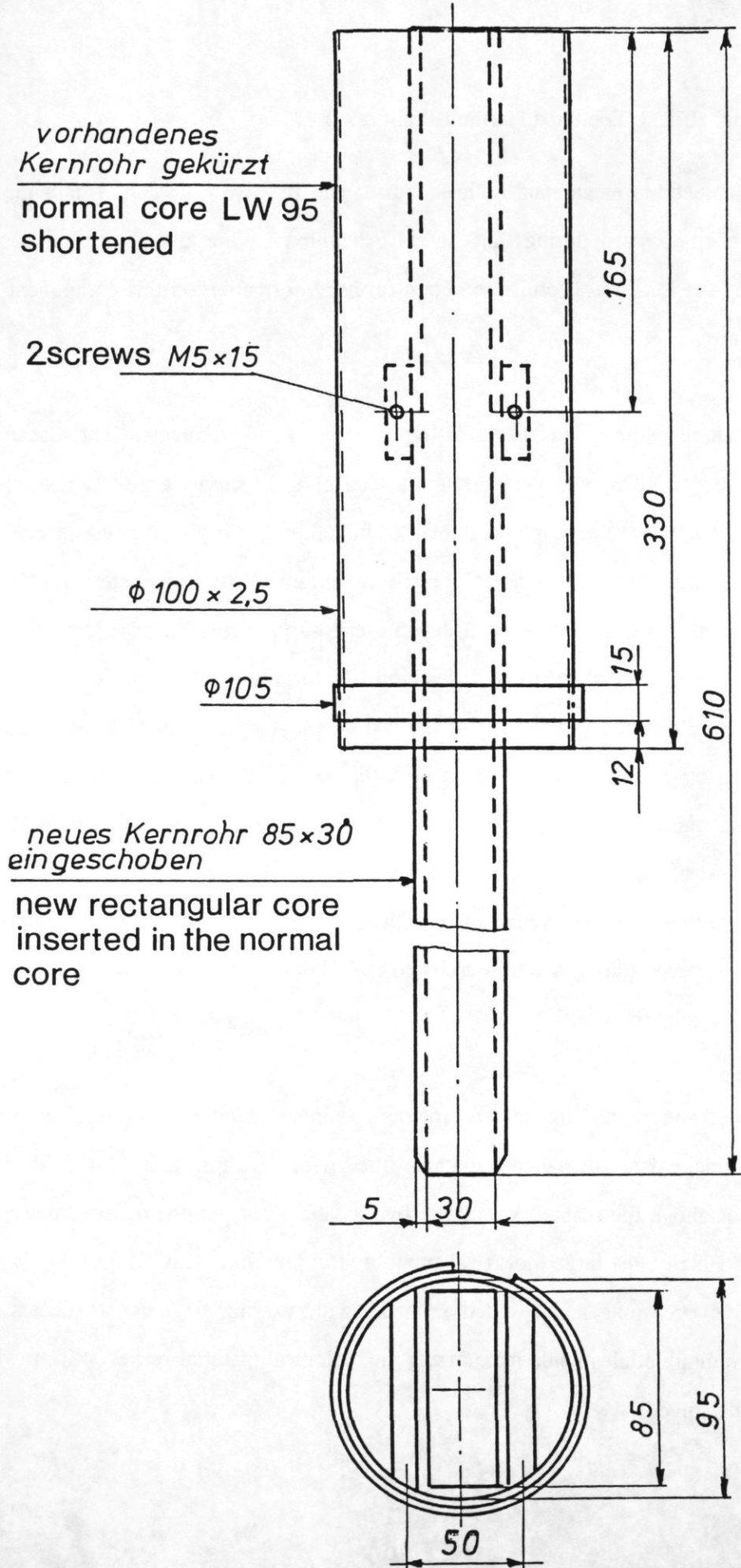

7.2 The benthos

7.2.1 Megafauna (Eric J. Foell and Hartmut Bluhm)

Studies on the epibenthic megafauna initiated during the first two DISCOL campaigns were successfully carried forward during the current expedition. Four distinct techniques were employed during the DISCOL 3 cruise to obtain further information on this component of the benthic community.

Two of these techniques provided images of the seabed and its inhabitants. The Ocean Floor Observation System (OFOS) was deployed for a total of eight survey transects ranging from 0.5 to 7 nautical miles (nmi) in length and obtained both 35mm still photographs and videotape recordings of the sea floor. The new Free-fall Benthos Observation System (FBOS) was lowered for six deployments, each several days in length, and provided excellent 35mm time series still photographs at a static sea floor location. Unfortunately, the unit failed to properly respond to a release command at the end of the sixth deployment and is presumed to be lost. Hope for recovering are still not given up with the help of the two cruises SO 78 and 79 working in the same area. However, since its position is well documented and only a few nautical miles west of the location of the FBOS unit previously lost near the DEA center (see DISCOL 2 Cruise Report), hope remains that both instrument packages and their valuable data content will be retrieved during a future cruise to the DISCOL area, perhaps through use of a research submersible at the site.

Two further methods were utilized to provide specimen material and other samples to supplement the image data. A baited trap chain fitted with six traps (at 0, 5, 10, 30, 50, and 100 m elevations above the seabed) was set at five locations for periods of from one to three days in length. Finally, the large biological trawl used in previous DISCOL cruises was again deployed on five occasions and resulted in hauls with varying degrees of success. The problem of excluding nodules while maximizing the biological material retrieved in trawl hauls remains yet to be solved.

7.2.1.1 OFOS deployments

Following the system previously instituted, the eight OFOS deployments made during DISCOL 3 (Figure 13 and Table 3) were sequentially numbered from 26 through 33 (since the last OFOS deployment of the DISCOL 2 cruise had been OFOS 25). A similar sequential numbering system was used for deployments of other equipment.

Table 3: Data on OFOS employments with times of bottom views recorded on tape and numbers of photographs achieved.

Ship/DISCOL station	OFOS number	Date	Station time (min)	Bottom in view (min)	Number of photographs
27/393	26	Feb. 3	200	18	36
64/429	27	Feb. 9	756	395	750
71/436	28	Feb. 12	511	281	780
102/464	29	Feb. 15	580	357	800
112/473	30	Feb. 17	535	307	1600
127/487	31	Feb. 18	581	354	1600
140/501	32	Feb. 20	599	353	1600
141/502	33	Feb. 21	568	349	800
Total			4330	2414	7966

OFOS 26 was intended to be a NW to SE traverse of the DEA, but was prematurely terminated due to a short in the e-m cable caused by a faulty power connector plug on the sub-sea telemetry housing. About 35 photographs were obtained during approximately 12 minutes of functional transect time outside the DEA at the northwestern end of the intended transect.

After approximately 200 m were cut from the end of the e-m cable, its capacity to conduct multi-plexed signals (data and video streams) returned. OFOS 27 then repeated the NW to SE transect planned for the previous run and successfully completed it. Over 700 photos were obtained from within the DEA as well as from outside the experimental area at the NW and SE ends of the traverse.

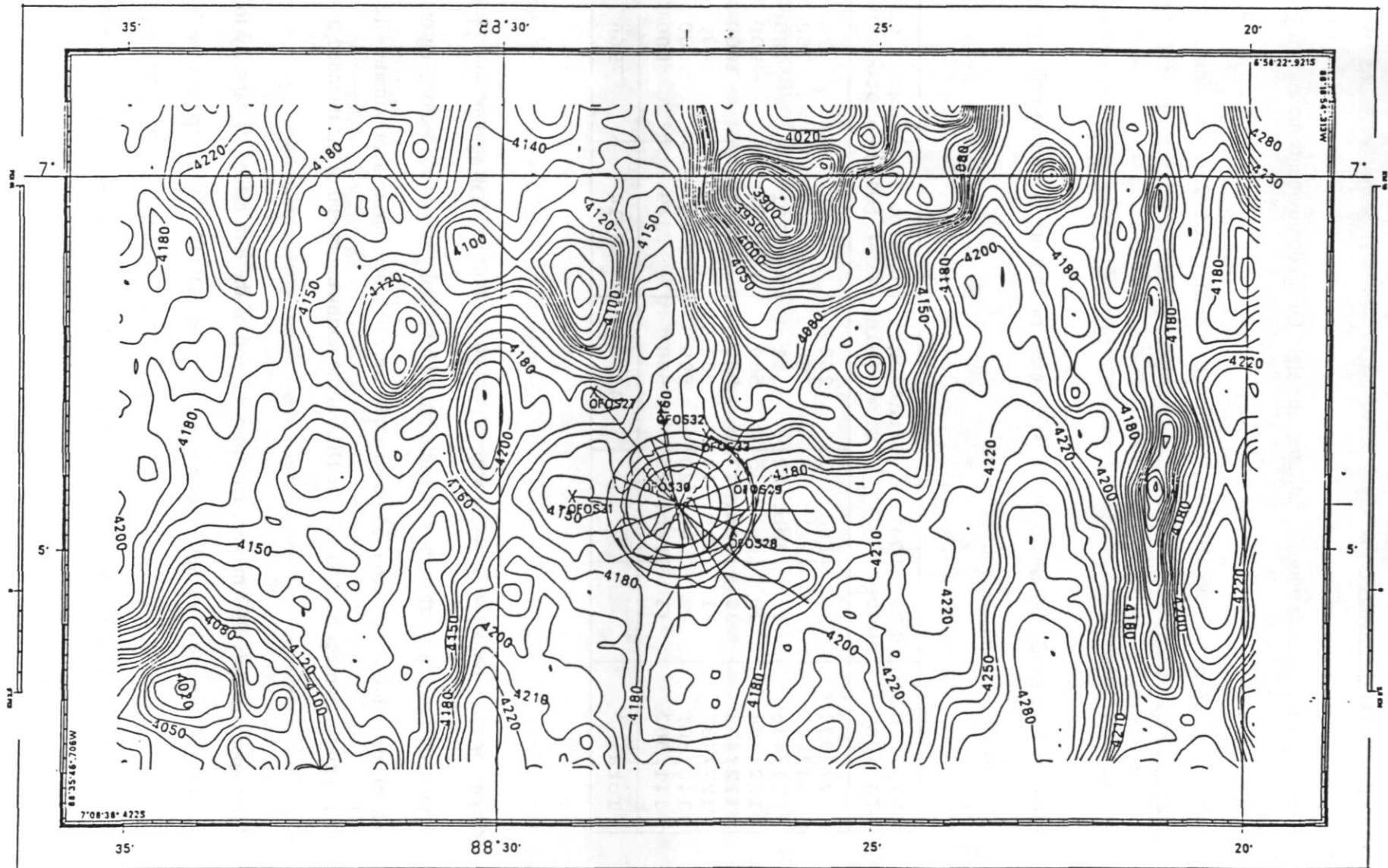

Figure 13: All OFOS runs within the DEA

OFOS 28 attempted a circular traverse within the DEA periphery starting in the PNE sector (Fig. 13) and proceeding in a clockwise direction. Navigation of such a precise course was facilitated by the functional transponder net consisting of five units placed prior to initiation of the sampling program. This net had been expected ever since DISCOL became a reality and considerably improved our ability to acquire precisely placed samples and to maintain exacting courses during towed instrumentation deployments. During this OFOS run, the video signal was poor throughout the deployment indicating a gradual deterioration of e-m cable integrity. Nevertheless, nearly 750 excellent seafloor photos were obtained.

After a further 200 m of cable were removed and a new termination was created, OFOS 29 completed the clockwise circular traverse initiated during the previous OFOS run. This deployment started in the PN sector and progressed to the PSW from where a northeasterly course took the instrument package past the location of the FBOS unit lost during DISCOL 2 and relocated with side-scan sonar during the current cruise. Although another nearly 800 excellent photos resulted, we failed to observe any trace of the missing FBOS unit.

A renewed NW to SE traverse of the DEA was the subject of OFOS 30 which passed through the DEA center and continued southeasterly well beyond the impacted area. During this run, both still cameras were loaded with film in order to acquire stereo images of the seafloor that would permit making depth of penetration measurements on the plow-harrow tracks. However, the film in camera B was improperly installed and slipped diagonally across the lens creating somewhat slanted and irregularly spaced images which should, nevertheless, still be of some use.

OFOS 31 was made after renewed water entry caused an additional 500 m of e-m cable to be severed and a new termination to be potted in epoxy resin. This traverse passed from W to E through the DEA center and was a good run with nearly 800 stereo photos being exposed and acceptable video quality throughout the on bottom period of the deployment. Due to continuing problems with flooding in the darkroom and with the new developing machine, it was decided to delay further film processing until after the cruise was concluded.

OFOS 32 and 33 were back-to-back deployments. The former run passed from NNW to SSE through the DEA center, while the later attempted a circular clockwise traverse around the perimeter of the DEA area. Both runs were successful and resulted in a total of nearly 1600 additional photo exposures of the seabed.

In general, our observations during OFOS deployments showed that the plow-harrow disturber tracks created nearly 3 years ago were now heavily influenced by sedimentation (either through deposition of new material or through lateral current driven movement of existing material or both processes simultaneously) and that the relatively crisp and distinct track edges evident during DISCOL 1, and to a somewhat lesser extent during DISCOL 2, were now more rounded and muted. Only the deepest tracks were still well-defined and easily visible, although the lighter colored, deeper sediment layers exposed and turned onto the surface by the plow-harrow remained widely in evidence.

On a purely subjective basis, larger numbers of megafauna seemed to be present in the disturber tracks than previously seen, particularly the hermit crab Probeebei mirabilis, as well as several holothurian and ophiuroid species. Most sessile life forms such as stalked crinoids, sea pens, sponges and xenophyophores were still missing in the tracks, although at least one large white anemone was noted in a disturber track during OFOS 30. The ability to move, for example by drifting or rolling across the sea floor, may explain this observation.

Between disturber tracks, more animals could be recognized than during previous DISCOL cruises. Numerous swimming medusae were observed and photographed within a short distance of the seabed. A few species not previously seen were also photographed, including several new sponge categories based on morphological types, a few holothurians and at least one type of fish.

More detailed results and conclusions can not presently be given and will have to wait until all photographic material has been processed and, along with the videotaped recordings, carefully analyzed.

7.2.1.2 FBOS deployments

The new FBOS was deployed at three general localities and under various conditions. A time interval of about 3.5 minutes was consistently used between automatic exposures.

Three deployments (FBOS 9-11) were made about 3.2 nmi south of the DEA. The first of these (FBOS 9) carried a newly constructed baited trap mounted to a pole within the camera's field of view. A second deployment at this site (FBOS 10) was made without bait, while a hird (FBOS 11) carried a pole to which a current strength and direction indicator flag had been attached. The pole was designed to pivot into the camera's field of view once the sea floor was reached (it normally took about 60-65 minutes for the FBOS to fall through the water column and attain the seabed), but the pole failed to fall down and the third FBOS deployment ended up being similar to the second. This turned out to be fortunate since a problem with the film slipping out of a sensing switch in the BENTHOS camera was responsible for only 70 or so exposures being acquired during FBOS 10. The other two FBOS deployments at this location produced a full complement of nearly 800 photographs.

Two further deployments were made near the DEA center (FBOS 12 and 13). The first of these carried no bait while the second was again fitted with the baited trap. Both carried a current indicator flag and provided nearly 800 seabed photographs.

The last FBOS deployment (FBOS 14) was made without bait and the unit was placed several nautical miles west of the DEA. This deployment failed to be completed due to possible problems with a release transponder, to buoyancy float failure, or to jamming of the attachment chain. As previously stated, it is expected that recovery attempts will be made during future cruises to the region since both this unit as well as the one previously lost contain valuable time series photographic data in addition to the value of the instrumentation attached to the FBOS tetrapod itself.

Results of the FBOS deployments await completion of the analysis process which was already initiated aboard ship during the cruise. In general, deployments without bait provided ample evidence of the normal and very slow pace of life, pattern of movement, and megafauna

appearances at any given location, while baited deployments apparently proved to be attractive to a large and varied assemblage of highly mobile species that were drawn into the camera's field of view.

7.2.1.3 Trawl deployments and preliminary results.

Five large biological trawl hauls were made during DISCOL 3 with various degrees of success. All hauls were successful in so far that bottom contact was achieved and sea floor material was recovered, but the quality and quantity of the biological material collected varied considerably between the five tows.

Trawl 7 was started at 07°08.5'S, 88°26'W and proceeded with the ship moving toward 140-150° against the wind. A medium bag (about 15 buckets) of material was collected with a relatively small and typical portion of biological material in poor condition.

Trawl 8 commenced at 07°09'S, 88°27'W and obtained a full bag (about 25 buckets) of material consisting predominantly of very large (10-15cm) nodules with smaller quantities of sediment and little of biological significance.

Trawl 9 was initiated at 07°02'S, 88°23'W and represented the best trawl collection so far obtained in the DISCOL area. Although the cod end was filled (a full bag of at least 25 buckets) and contained numerous nodules, the catch also included a large amount of material of biological origin. Even some rather delicate animals such as sea cucumbers (holothurians), gorgonarians, and polychaetes arrived on deck in a recognizable condition which is atypical for most trawl hauls in nodule fields. We believe the large quantity of sediment taken in this haul helped to "insulate" the biological material and reduced the usual grinding effect and consequent deterioration of biological specimens resulting from the nodules in the net.

The next trawl (Trawl 10) was less successful and returned a medium sized bag of mostly nodules with little sediment and biological material. It began at 7°1'S, 88°35'W and proceeded toward the location of a baited trap chain previously implaced (RK 108).

A final trawl haul (Trawl 11) was made from 07°04'S, 88°27.6'W in a southerly direction and reached the seafloor just south of the DEA where a previous OFOS deployment had indicated scant nodule occurrences. It was hoped that we would have a better chance at obtaining more biological specimen material and fewer nodules, but the cod end, although filled with about 25 buckets of a sediment -nodule mixture, still contained little material of biological interest.

The five trawl hauls did succeed in providing representatives of all major megafauna phyla. Numerous sponge morphotypes, including several good specimens of *Hyalonema* sp., and cnidarians including anemones, gorgonarians, and *Bathypathes lyra*, were present among others. Crustaceans included several species of shrimp, amphipods, isopods, a pycnogonid, and numerous decapod crabs including the parapagurid *Probeebei mirabilis* as well as several galatheids. Mollusca were represented by several gastropods, bivalves, scaphopods and a good specimen of cirrate octopod. Echinoderms were abundant and included asteroids (especially a good specimen of *Hymenaster* sp.), numerous ophiuroids, several entire holothurians, and pieces of echinoids and crinoids. Several bryozoa and brachiopoda were also in the trawl collections as well as a few vertebrates represented by fishes such as the chlorophthalmid *Ipnops* sp. and at least one additional unidentified, but well preserved form.

At this point it is worth mentioning that an excellently preserved specimen of a dark stalked crinoid was accidentally taken in a box corer and arrived on deck attached to a nodule with only the stalk broken at one point. Several amphipods and presumably parasitic gastropods were discovered attached to the crinoid. All of this material will be curated by the Senckenberg Museum (Frankfurt am Main) and will be distributed to interested taxonomic specialists for further study.

7.2.1.4 Baited trap deployments and preliminary results.

A total of five baited trap chains were set during DISCOL 3. Traps were baited with fish chunks and were allowed to sit for one to three days before being retrieved and examined.

Four trap chains were successful and provided samples reflecting the typical distributions of

large amphipods (*Eurythenes* sp.) in the upper traps and smaller amphipods in the lower, particularly in the 0m traps. Several specimens of fishes (zoarcids and synphobranchid eels) and a single ophiuroid were also obtained from the traps at 0m elevation. All baited trap collections await a more detailed analysis in which the size ranges, sex and vertical distributions of the collected amphipods will be more carefully investigated.

7.2.2 Macrofauna (Christian Borowski)

Due to a recently installed new winch that was used for box coring, the deployments of the box corer in were in general successful and disturbance of the samples during sampling did not occur. Samples from areas that were disturbed by the plow harrow and undisturbed samples were definitely distinguishable, whereas on former cruises this caused problems in at least some cases. The use of photcameras, that took pictures of the sea floor immediately before the box corer touched the ground, helped to interpret the appearance of the samples.

Those samples which had their origin in undisturbed areas had a very soft upper layer of 6-9 cm thickness, which was nearly fluid in the upper 2-3 centimeters. This layer was followed by a more solid mud layer which changed into a clay consistency at a depth of 10-12 centimeters. The sediment surface of these samples was plain and smooth.

Ten disturbed samples could be gained from plow harrow affected areas within the DEA (Fig. 14). According to the OFOS observations of the plow harrow tracks, we found out that the nature of the tracks has changed since the last cruise. The track samples of DISCOL 1 and DISCOL 2 were characterized by having wavy sediment surfaces with clear cut edges where the plow harrow had dug in the ground and the surface sediments consisted mainly of the sticky lightgray clay that was laid exposed. The samples of this cruise showed that the tracks were covered more or less with dark, soft and fluid surface sediment. The troughs were semifilled in part and the clear cut track structures were smoothed by the overlying sediment. Light clay from the deeper sediment layers only appeared in some track samples and dominated the track surfaces.

Manganese nodules of the cauliflower type of various sizes (up to diameters of 20 cm) were found lying on the sediment surface as well as in deeper layers. Most of the undisturbed



Figure 14: Disturbed box-corer sample on deck of RV SONNE

samples had two to seven nodules at the surface and nodule-free undisturbed cores were rare. The track samples had higher numbers of buried nodules and most of them were tilted from their natural position.

A microscopic investigation of the macrofauna could not be carried out aboard ship so that statements on the recolonization since the last cruise cannot be made here. Those animals that are big enough to be seen without magnification are still very scarce and were rarely detected while sieving the samples. A suspicion that the number of conspicuous bivalves and gastropods as well as bigger polychaetes was slightly higher than in the samples of the last cruise remains a subjective impression that has yet to be proven.

7.2.3 Meiofauna (Christian Bussau)

In total, more than 170 samples were preserved to study meiofauna. These samples will be

used predominantly for work on harpacticoids and nematodes. As mentioned earlier, all other taxa as well will be considered during sorting. There was no opportunity to study the meiofauna on board the SONNE because of the sea swell and the ship's vibrations.

7.2.4 Nodule epi- and crevice fauna

A total of 69 nodules with diameters of 6-12 cm were inspected for their epifauna under low power magnification. Invertebrates were isolated from the nodules and preserved in 4% formaldehyd. Nearly all the specimens were of small size.

Abundant taxa:	Porifera	mostly very small specimens	
	Bryozoa	mostly small specimens	
	Polychaeta	mainly tubes, probably most of the empty	
Rare taxa:	Scyphozoa	tubes of polyps	
	Actinia	Octocoralli	Hydroida
	Brachiopoda	Bivalvia	
	Gastropoda	parasitic on crinoid	
	Crinoida	Ascidia	

For the collection of in- or crevice fauna 29 nodules were opened and inspected with low power magnification. In some instances Polychaeta and Tanaidacea were found, carefully washed out of the sticky sediment and preserved. Subsequently, the nodules were broken into small pieces and washed three times in filtered seawater. Sediment plus meiofauna were concentrated in a 50 μ m sieve and preserved for later inspection.

Further 30 nodules were preserved in total.

7.2.5 Rhizopoda (Caroline Maybury)

7.2.5.1 Foraminiferida

Preliminary results from rose-bengal-stained DISCOL III material show that the upward trend

in the occurrence of 'live' foraminifera from one post impact sampling phase to the next is maintained (THIEL et al., in press); but the number of 'live' individuals is still lower than that observed for the pre-impact sampling phase.

A characteristic, interstitial, foraminiferal nodule fauna was discovered by breaking nodules with a screw-diver. The agglutinated genera: *Crithionina*, *Haplophragmoides* and *Thurammina* were frequent nodule crevice inhabitants: always characterized by bright orange (ferric-oxide rich) tests. Their relative abundance (over 30 entire, or nearly entire specimens), orange colour and 'fresh' (not manganized) appearance belies their fortuitous occurrence within the nodules; although it is difficult, as with all agglutinated species, to determine whether they are 'live'. A problem which is compounded by the somewhat violent extraction procedure employed. Less frequently long, fibrous, dichotomously branched and unbranched rhizamminids were observed permeating the radial nodule crevices. These specimens were always 'live'.

Recovery of the current meter after a two-and-a-half year period, surprisingly revealed a dense, encrusting, agglutinated fauna colonizing the bouyancy devices deployed at 15m above the ocean's floor. These encrusters showed a preference for substrate type; settling only on the orange plastic surfaces of the bouyancy devices and not on their metal components. All were fibrous, heavily agglutinated forms of rhizamminid affinity. Three distinct growth habits could be recognized. The first is an open, dichotomously branched network with long, thin, straight rami. The second is a more compact, dichotomously branched structure with meandrine rami and the third a closed, tight meshwork resembling matted hair. The agglutinated material was similar in all forms comprising sediment grains, radiolaria, diatoms, sponge spicules and ferromanganese micronodules. This composition is identical to the bottom dwelling rhizamminids in the DISCOL area; but it is somewhat curious to see the utilization of ferromanganese material in the tests of these foraminifera 15m above the ocean's floor. Either, this material was suspended in the water column as a consequence of a benthic storm or, it was actively produced by the organisms. This latter possibility seems unlikely given the slow growth rate of nodules in the area (estimated at 16mm per million years).

7.2.5.2 Xenophyophoria

One-hundred and seventy-three complete or nearly complete xenophyophores were recovered from 46 box cores. Only 5 (KG 1458, 1466, 1576, 1488, 1491) of the 51 box cores did not contain xenophyophores. A further 7 complete specimens from the multiple core deployments (MC 339, 344, 346, 351-352, 364) and numerous fragments of *Stannophyllum* from trawls 7-9 were recovered. This number of xenophyophores far exceeds that of the first DISCOL cruise, where 29 intact specimens and 20 large fragments were collected from 77 box cores and of the second cruise, where 72 specimens were collected from 35 box cores and 13 multiple cores. The DISCOL xenophyophores, therefore, must now constitute one of the world's largest and most comprehensive xenophyophore collections.

A total of 18 species (of which 16 are new) can be recognized in the DISCOL III material. Seventeen of these have been recorded in the previous 2 DISCOL cruises. In all of the DISCOL sampling phases *Ammoclathrina saganella* (Haeckel, 1889) is the dominant species in the DEA and *Stannophyllum* is always abundant in the trawls; but extremely rare in cores. In order to avoid citing manuscript names, the DISCOL xenophyophore species can be categorized into the following broad taxonomic units: 7 psamminids, 6 syringamminids, 3 psammettids, 1 stannomid and 1 species of questionable affinity.

7.2.6 Bacterial numbers and microbial enzymes (Antje Boetius)

A total of 210 sediment subsamples from 7 multiple corers were collected for the enumeration of bacteria at 5 stations from inside and 2 from outside the DEA at the previous sampling sites. A total of 84 syringe samples (20cm³) were collected from the same cores and deep frozen for analysis of the sediment water content.

16 small corer tubes from 2 multiple corers were used for a shipboard experiment. The top 10 cm from each core were sliced in 1 cm steps, 160 subsamples were deep frozen for biomass and water content analysis. Enzyme activity and protein content were analysed on board ship, 160 subsamples were fixed for enumeration of bacteria.

The shipboard disturbance experiment presented already preliminary results. Enumeration of bacteria in the DEA sediments showed a change of the distribution of bacteria with sediment depth two weeks after disturbance set in this area. A normal gradient of microbial parameters in deep sea sediment shows highest numbers of bacteria as well as highest activity (ATP, H-3 Leucin incorporation, enzymatic hydrolysis rates) in the top cm, decreasing to about 10% and less within the first 10 cm. Two weeks after the original disturbance in the DEA showed the lack of such a gradient.

The first data from the shipboard experiment indicate similar results, looking at the change in microbial activity: during the first two weeks the natural gradient of hydrolytic activity was changed by the artificial disturbance to a rather even distribution of values of hydrolysis rates within the top 10 cm. After two weeks a gradient evolved which showed higher activity in the 5-10 cm layers, even compared to the undisturbed cores from the same station. The sediments did not consolidate to its original structure in the top 6 cm.

The analysis of biomass parameters and sediment water content is needed for the final evaluation of the data, so that specific activity per biomass and per sediment dry weight can be compared.

7.2.7 Biochemical activities and chemical sediment constituents

Subsamples for the determination of biochemical activities and chemical sediment constituents were collected from 49 tubes out of 13 multiple corers and analyzed or preserved in numbers as given in Table 4. All subsamples cover the upper 4 or 5 cm of the sediment.

All final subsamples consist of 1 cm thick layers. Many determinations had to be done during the cruise because the storage and transport of the frozen samples is difficult, but some of the material had to be transported home for further analyses. Determination of the electron transport activity was terminated when we realized that all values fell beyond the limit of detection.

The results seem to verify an increase in biological activity compared to DISCOL 2 measurement. The pigment values seem higher than those on the pre-impact samples during DISCOL 1, and we wonder whether this is due to natural variability.

Table 4: Number of subsamples available for analyses

Determination purpose	No. of sub-samples
Energy charge	256
Electron transport activity	75
Desoxiribonulceic acid	275
Protein (one hydrolysis)	308
Chloroplastic pigment equivalents	256

7.3 Macroplankton and Micronekton, preliminary Results (W. Beckmann)

During the time of the investigations, the Deep Scattering Layer could be recorded without any further distinct stratification between 300 and 500 meter depths (Figure 15), i.e. the range of minimum oxygen concentrations of about 0.6-0.7 mgO₂/l. Figure 16 shows a smoothed oxygen profile from hydrocasts of two CTD-stations. At dusk, when the DSL ascended, it split up into an upper and a lower part, the latter reaching the surface layers somewhat later.

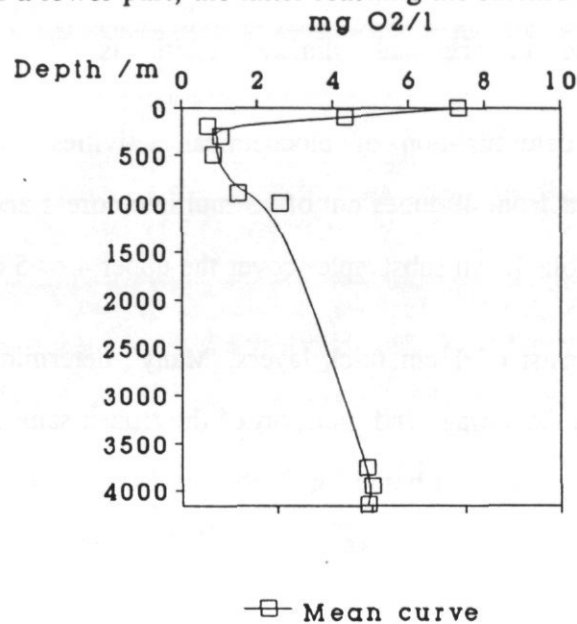

Figure 16: Oxygen concentration profile, Tropical SE- Pacific Ocean, DISCOL 3.

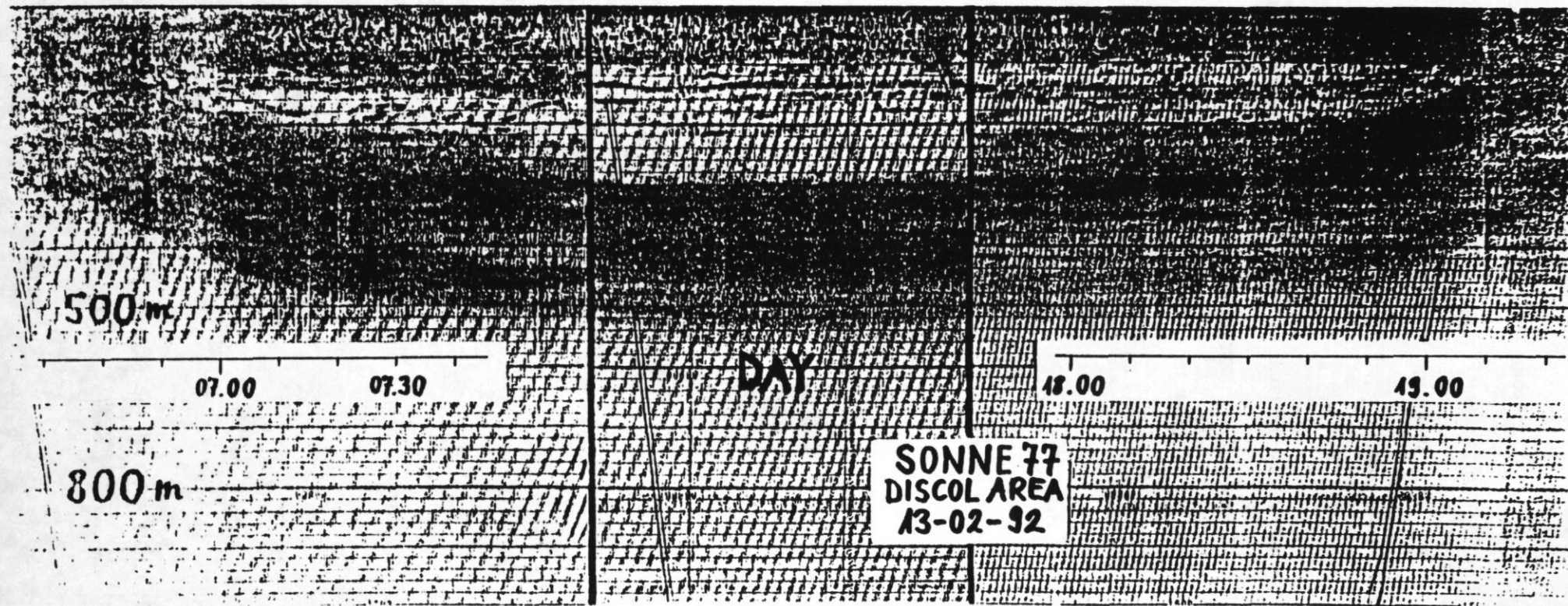

Figure 15: The Deep Scattering Layer (DSL) in the DISCOL area during SONNE 77, February 1992.

The MOCNESS samples from the DSL and underlying strata revealed a distinct vertical faunal stratification of the water column. During daytime, Euphausiacea dominated in the upper part of the DSL, while in its lower part (450-500 m) high concentrations of Thaliacea were found. During nighttime, both groups had nearly disappeared from these layers where calanoid copepods then became most important. Samples from below the DSL down to 1050 m depth were characterized by small fish and Decapoda during both day and night. Below 1050 m the amount of micronekton decreased markedly. The day and night samples from the 1050-1250 m layer caught many larger calanoid copepods of the genera *Euchaeta* and *Lucicutia*. Below 1450m, zooplankton and micronekton densities distinctly decreased again.

7.4 Side-Scan Sonar, initial results

Tracks of the plow-harrow deployments from February 1989 (DISCOL 1) were detected in all side-scan sonar profiles. The area with plow-harrow tracks is marked in Fig. 17. Highest concentration of these marks was found near and up to 700 m to the SE from the DEA-center

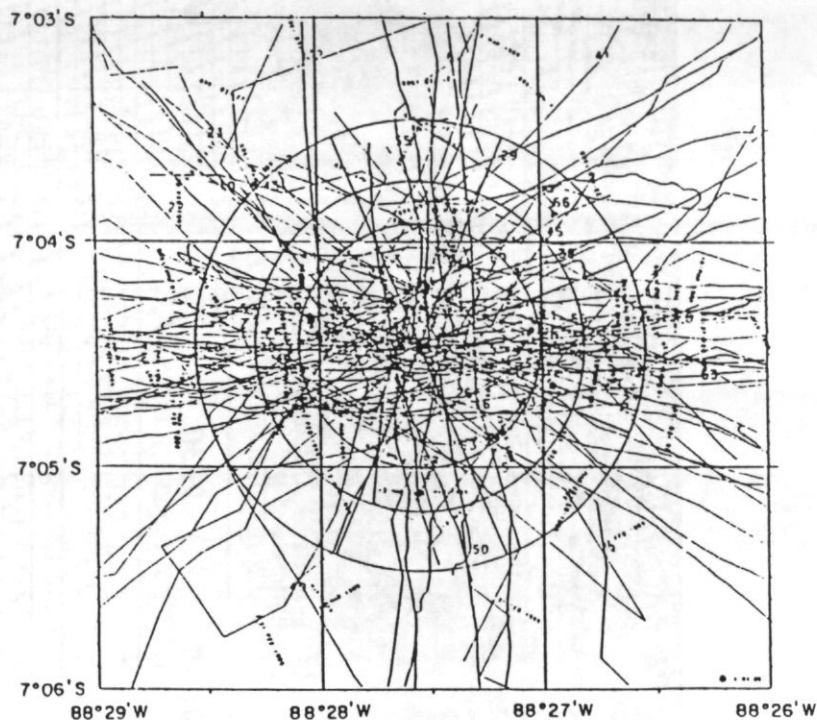

Figure 17: Chart showing the location of the disturber tracks in the DEA (from THIEL & SCHRIEVER, 1989).

(Fig. 18, 19). The average widths of most of the recorded plow marks ranged between 6 and 8 m. Twice, a 16 m wide track was recorded (Fig. 20). This 16 m wide configuration of the plow-harrow was used during DISCOL 1 only two times because of handling problems on deck. The following 76 tracks were run with the 8 m wide configuration (THIEL & SCHRIEVER, 1989). Some tracks are only 1-2 m wide, eventually deriving from a "running on the heel" towing mode. The tracks show depths of about 30 cm.

Preliminary analyses of the orientation of principal plow-mark axes show preferred alignments in the E-W direction, as could be expected according to the track distribution of DISCOL 1 (THIEL & SCHRIEVER, 1989). In some parts of the side-scan records, tracks of the rollers can clearly be detected. These were mounted on the edges and in the center of the plow-harrow. Using the SONARTECH transponder navigation we reached an accuracy of about 5m inside the DEA, proved by the reception of the same track during SO77. dt 2 and dt 5.

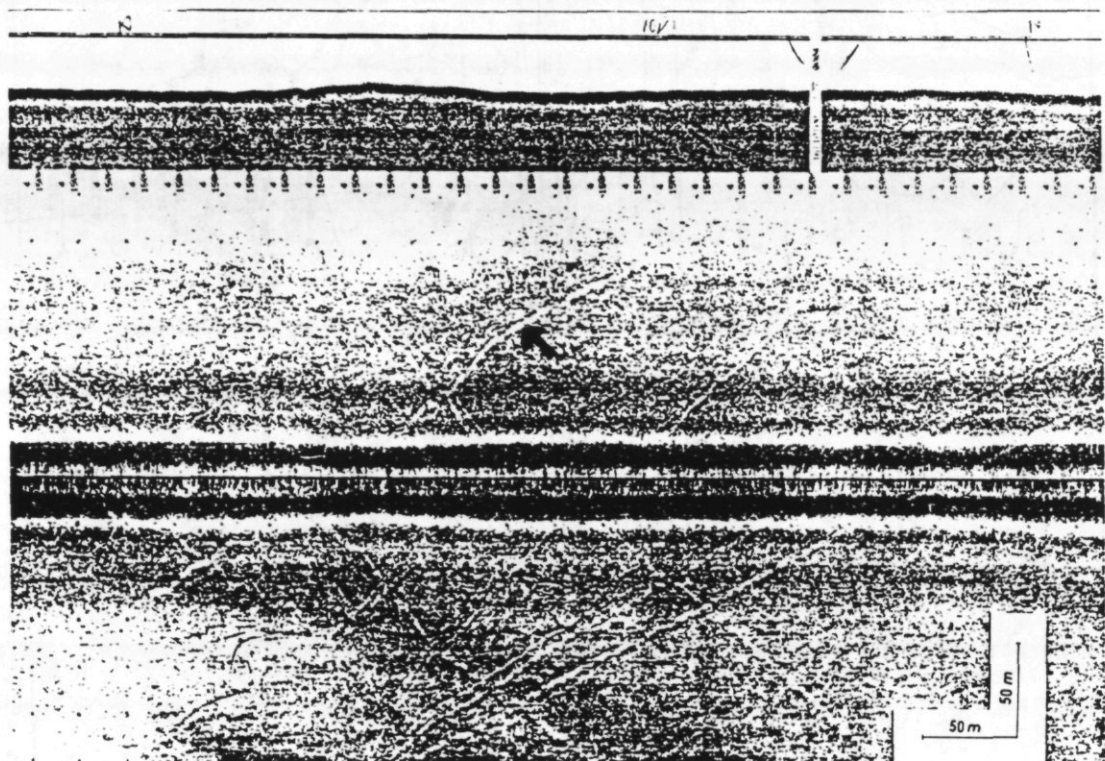

Figure 19: Side-sonar record of plow-harrow tracks

The results of the photography showed that the depressor was not, as expected, at the same depth as the side-scan sonar unit, but about 10 m above the connection point of the "fish" and

depressor. Hence in the first two operations there were only a few pictures of good quality. About 50 photos, mainly from undisturbed regions of sea bottom, were obtained from SO 77. DT 2 and 5. As a result of this experience, we reduced the cable length between connection point and depressor up to 10 m for the last profile SO 77. DT 8. This film will not, however, be developed during the cruise.

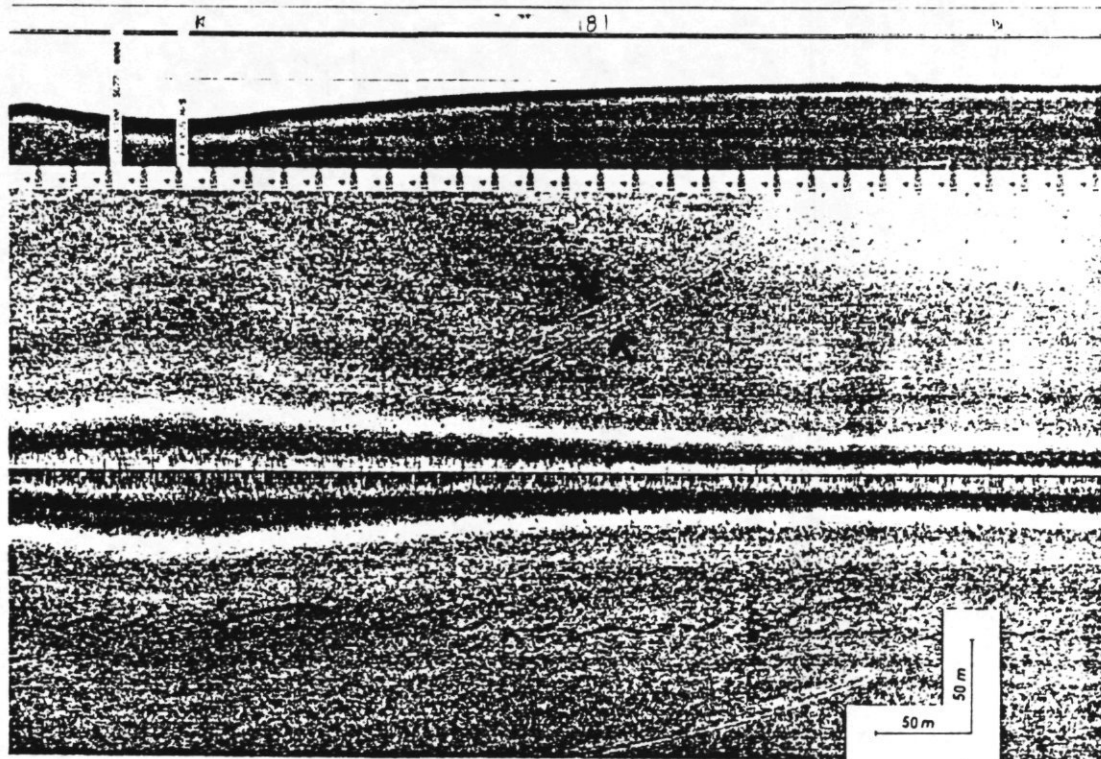

Figure 20: Side-scan sonar record of 16m wide plow-harrow track

7.5 Analysis of resedimentation using x-rays

A total of nine multiple corer samples (5 from the central stations and 3 from the peripheral stations within the DEA and as well as 1 from a site about 3 nm north of the DEA center) were acquired. The results of the x-ray analyses are presented in table 5 and figure 21.

All samples from within the DEA show resedimentation ranging from 1 to 30mm. As already described by Kukert (1990) the impression emerged that resedimentation was somewhat patchy

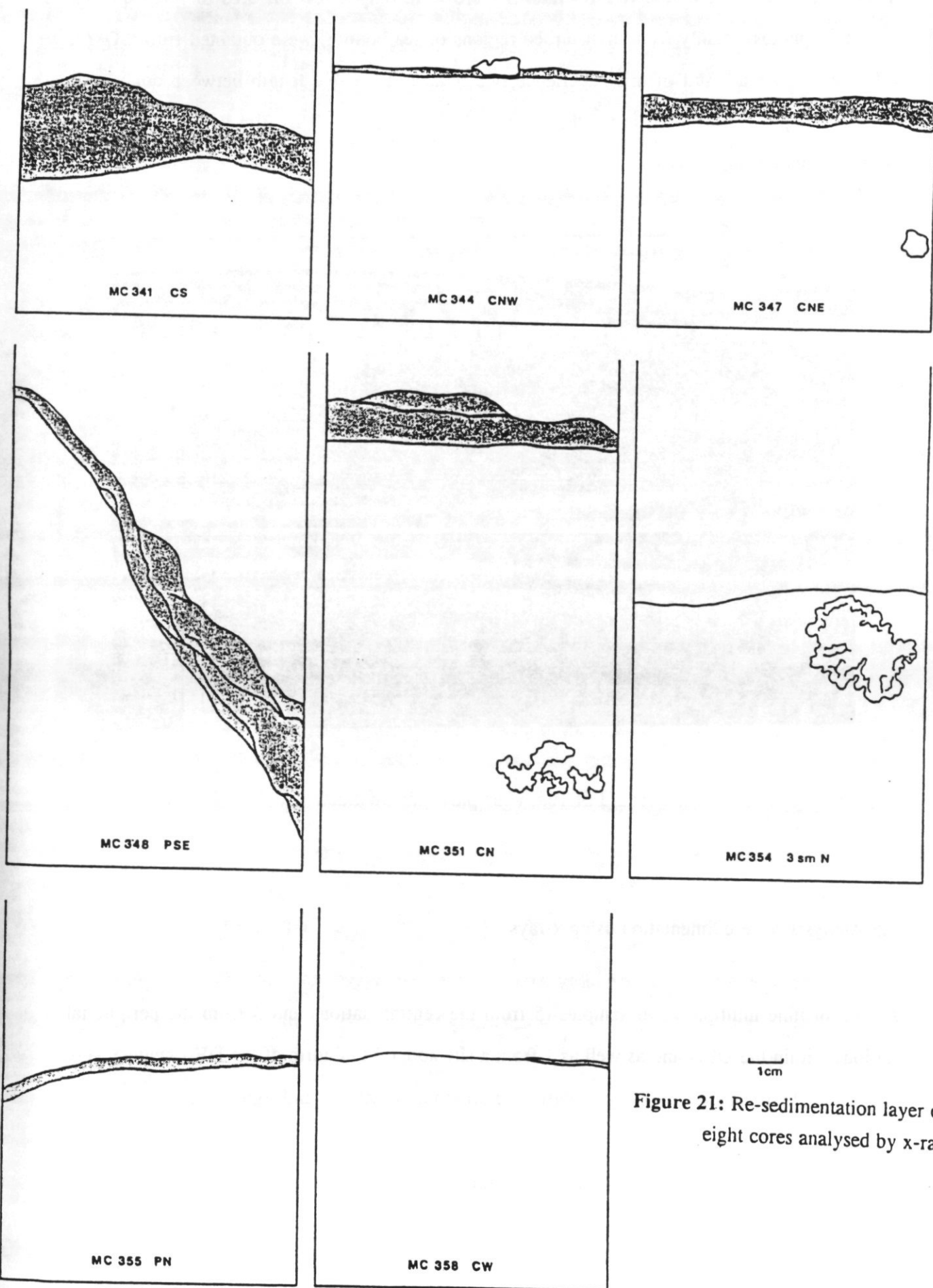

Figure 21: Re-sedimentation layer of eight cores analysed by x-ray

with higher rates at the CNE and CN stations, and even little higher yet at the PN station. The highest resedimentation rate was shown in samples from the CS and PSE stations. It is assumed that these samples were taken close to a plow harrow track. The higher resedimentation rate at the CNE and CN stations compared to CW and CNW stations may be explained in predominant bottom currents measured during DISCOL 1 (THIEL & SCHRIEVER 1989) which were primarily oriented in northerly direction. The 3mm layer at the PN station is an additional indication for this transport. It is assumed that most of the plume has resettled within the first 2 miles of its creation.

Table 5: Resedimentation layers analyzed by x-ray images

Ship/DISCOL station	MC number	Date	Station within DEA	resedimen. layer (mm)
24/390	341	Feb. 3	CS	10 - 30
33/399	344	Feb. 4	CNW	1 - 2
55/418	347	Feb. 8	CNE	7 - 10
56/419	348*	Feb. 8	PSE	5 - 20
75/439	351	Feb. 12	CN	7 - 15
89/453	354	Feb. 14	3nmN	0
92/455	PNW	Feb. 14	PN	3
110/471	358	Feb. 16	CW	1 - 2

*sample out of a track

Multiple corer 348, PSE station, was taken from within a plow-harrow track. This was visible on the oblique sediment surface which showed a difference of 15 cm from the highest to the lowest sediment horizon. On top of this oblique sediment surface the x-ray image shows a 5 - 20 mm resedimentation layer with varying structure and difficult to explain. It might be possible that different layers are lying on top of another, or that softer sediment was washed over the first layer by further sedimentation. However, bottom currents may have transported the sediment in the time interval between DISCOL 1 and DISCOL 3. Differences in the appearance of the sediment surface noted during observations made on DISCOL 2 and 3 have already been reported in chapter 7.2.1.1.

8. Literature

- Amos, A.F. & O.A. Roels, 1977: Environmental aspects of manganese nodule mining. *Marine Policy*: 156-163.
- Barnett, P.R.O., J. Watson, D. Conelly, 1984: A multiple corer for taking virtually undisturbed samples from shelf, bathyal and abyssal sediments. *Oceanologica Acta* 7(4): 399-408.
- Bischoff, J.L. & D.Z. Piper (eds.), 1979: *Marine geology of the Pacific Manganese Nodule Province*. Plenum Press, New York, N.Y., 842 pp. plus Appendix of 6 Microfiche Cards.
- Burns R.G., 1980: Assessment of environmental effects of deep ocean mining of manganese nodules. *Helgoländer Meeresuntersuchungen*, 33: 433-442.
- Findlay, R.H., M.B. Trexler, J.B. Guckert & D.C. White, 1990: Laboratory study of disturbance in marine sediments: response of a microbial community. *Mar. Ecol. Prog. Ser.* 62: 121-133.
- Fleeger, J.W., D. Thistle & H. Thiel, 1988: Sampling equipment. In: *Introduction to the study of Meiofauna*. R.P. Higgins & H. Thiel, (eds.). Smithsonian Institution, Washington D.C.:115-125.
- Kukert, H. 1990: Analyzes of re sedimentation using x-radiography. In: G. Schriever, *Cruise-Report DISCOL 2, SONNE 64. Bericht aus dem Zentrum für Meeresforschung der Universität Hamburg*, 3: 39-44.
- Ozturgut, E., Lavelle, J., and Burns, R.E. 1981: Impacts of manganese nodule mining on the environment: results from pilot-scale mining tests in the north equatorial Pacific. In: *Marine environmental pollution. 2. Dumping and mining*, pp. 437-474, Geyer, R.A. (Ed.). Amsterdam: Elsevier Oceanographic Series 27B.
- Meyer-Reil, L.-A. 1991: Ecological aspects of enzymatic activity in marine sediments. In: Chrost, R.J. (ed.), *Microbial enzymes in aquatic environments*, SpringerVerlag, New York, : 84-95.
- Schneider J. & H. Thiel, 1988: Environmental problems of deep-sea mining. In: *The Manganese Nodule Belt of the the Pacific Ocean; Geological Environment, Nodule Formation, and Mining Aspects*. P. Halbach, G. Friedrich, U. von Stackelberg (eds.). F. Enke Verlag, Stuttgart: 222-228.
- Schriever, G. 1990: *Cruise-Report DISCOL 2, SONNE 64. Bericht aus dem Zentrum für Meeresforschung der Universität Hamburg*, 3: 50pp.
- Spiess, F.N., R. Hessler, G. Wilson, M. Weydert and P. Rude, 1984: *Echo I Cruise Report. SIO-Reference 84-3, Marine Physical Laboratory, Scripps Institution of Oceanography (San Diego, Cal.)*, 21 pp + appendices.
- Thiel, H. in press: Deep-sea environmental disturbance and recovery potential. *Intern. Rev. ges. Hydrobiologie*.
- Thiel, H., O. Pfannkuche, R. Theeg, & G. Schriever, 1987: Benthic Metabolism and standing stock in the Central and Northern Deep Red Sea. *P.S.Z.N.I: Marine Ecology*, 8(1):1-20.

- Thiel, H., and G. Schriever, 1989: CRUISE REPORT DISCOL 1, SONNE CRUISE 61, Balboa/Panama - Callao/Peru, with contributions by C. Borowski, C. Bussau, D. Hansen, J. Melles, J. Post, K. Steinkamp und K. Watson. Berichte aus dem Zentrum für Meeres- und Klimaforschung der Universität Hamburg 3: 91 pp.
- Thiel, H., C. Borowski, C. Bussau, A.J. Gooday, C. Maybury & G. Schriever in press: The impact of marine mining on the deep sea organisms. The DISCOL Project. Ocean Challenge.
- Velji, M. I. & Albright, L. J. 1985: Microscopic enumeration of attached marine bacteria of seawater, marine sediment, fecal matter, and kelp blade samples following pyrophosphate and ultrasound treatments. Can. J. Microbiol., 32: 121-126.

9. Appendices

9.1 The use of shiptime during DISCOL 3

Balboa/Panama 26.01. - 27.02.92 Balboa/Panama

1. 26. January 1992 harbour time and loading of equipment on board SONNE at Balboa harbour	40:28 h
2. 27. January 1992 depart Balboa/Panama 31. January 1992 arrival at work site	87:42 h
4. Sampling of DEA	
Tranponder Navigation	11:24 h
HYDROSWEEP exploration	07:13 h
OFOS	73:31 h
Float-/Transponder Tests	06:12 h
Multisonde	07:05 h
Box corer/Multiple Corer sampling (KG/MC)	198:19 h
FBOS	15:34 h
Baited traps (RK)	10:24 h
Trawl	34:09 h
Current meter	05:54 h
Side-Scan Sonar	67:34 h
MOCNESS	16:47 h
ship time between stations**	84:56 h
4. 22. January 1992 depart DEA for Balboa/Panama	
5. 26. February 1992, arrive at Balboa/Panama	90:23 h
27. February 1992 unloading of RV SONNE	34:25 h
Total time = 33 days	792:00 h

** = Includes time for changing boxes and cores of KG and MC.

9.1.1 Summary of ship time used for various purposes

1. In harbour	74:53 h
2. Transit between harbor and DEA	178:05 h
3. Sampling and measuring	450:12 h
4. Transit between stations	88:50 h
<hr/>	
Total time = 31 days or	792:00 h

9.2 Complete station list

Ship station/ DISCOL station	Gear ser. no	Water depth	Position
01-31-1992			
001/367	Multisonde 22	4.102 m	07°04.432 S 88°27.570 W
002/368	Recovering Cur. Meter Chain	4.152 m	07°04.140 S 88°28.230 W
003/369	MC 336	4.185 m	07°07.872 S 88°27.159 W
004/370	MC 337	4.168 m	07°07.505 S 88°27.099 W
005/371	Hydrosweep		
02-01-1992			
006/372	Float Test	4.225 m	07°08.731 S 88°37.015 W
007/373	MC 338	4.179 m	07°07.700 S 88°26.900 W
008/374	MC 339	4.169 m	07°07.525 S 88°27.037 W
009/375	Hoisting of FBOS 9	4.179 m	07°07.900 S 88°27.900 W
010/376	KG 1441	4.170 m	07°07.503 S 88°26.900 W
011/377	KG 1442	4.164 m	07°07.446 S 88°26.995 W
02-02-1992			
012/378	KG 1443	4.176 m	07°07.645 S 88°26.762 W
013/379	NAVTR 12	4.138 m	07°05.550 S 88°28.440 W
014/380	NAVTR 13	4.115 m	07°05.440 S 88°26.910 W
015/381	NAVTR 14	4.143 m	07°03.280 S 88°26.500 W
016/382	NAVTR 15	4.179 m	07°03.300 S 88°28.600 W
017/383	NAVTR 16	4.166 m	07°04.370 S 88°27.600 W
018/384	Calibration of Nav-trans-field	from to	07°04.370 S 88°28.018 W 07°03.648 S 88°36.144 W
02-03-1992			
019/385	Sidescan Sonar 1	from to	07°03.696 S 88°36.125 W 07°04.624 S 88°28.633 W
020/386	KG 1444	4.112 m	07°04.910 S 88°27.650 W
021/387	KG 1445	4.165 m	07°04.480 S 88°27.680 W
022/388	KG 1446	4.163 m	07°04.673 S 88°27.599 W

023/389	MC 340	4.163 m	07°04.681 S	88°27.591 W
024/390	MC 341	4.164 m	07°04.623 S	88°27.597 W
025/391	MC 342	4.155 m	07°04.396 S	88°28.661 W
026/392	Recovering of FBOS 9	4.179 m	07°07.900 S	88°27.900 W
027/393	OFOS 26			
028/394	KG 1447	4.153 m	07°04.427 S	88°29.603 W
02-04-1992				
029/395	KG 1448	4.149 m	07°04.405 S	88°28.675 W
030/396	Sidescan Sonar 2	from	07°02.581 S	88°34.468 W
		to	07°04.409 S	88°28.753 W
031/397	KG 1449	4.148 m	07°04.406 S	88°28.683 W
032/398	MC 343	4.149 m	07°04.377 S	88°28.677 W
033/399	MC 344	4.158 m	07°04.196 S	88°27.786 W
034/400	Hoisting of FBOS 10	4.180 m	07°08.045 S	88°28.013 W
035/401	Sidescan Sonar 3	from	07°03.423 S	88°34.406 W
		to	07°03.327 S	88°23.758 W
02-05-1992				
036/402	KG 1450	4.154 m	07°04.174 S	88°27.813 W
037/403	KG 1451	4.152 m	07°04.198 S	88°27.781 W
038/404	KG 1452	4.154 m	07°04.168 S	88°27.789 W
039/405	KG 1453	4.154 m	07°04.000 S	88°27.756 W
040/406	MC 345	4.154 m	07°04.215 S	88°27.776 W
041/407	TRAWL 7	from	07°08.579 S	88°26.100 W
		to	07°05.699 S	88°27.003 W
02-06-1992				
042/408	KG 1454	4.137 m	07°05.697 S	88°26.989 W
043	MOCNESS 1	from	07°05.670 S	88°27.009 W
		to	07°08.262 S	88°25.066 W
044/409	KG 1455	4.160 m	07°04.186 S	88°27.616 W
045/410	KG 1456	4.165 m	07°04.179 S	88°27.589 W
046/411	KG 1457	4.157 m	07°04.128 S	88°27.599 W
047/412	OFOS 27	from	06°58.958 S	88°32.078 W
		to	06°59.030 S	88°31.927 W
02-07-1992				
048/413	KG 1458	4.163 m	07°04.184 S	88°27.343 W
049/414	KG 1459	4.158 m	07°04.182 S	88°27.387 W
050/415	KG 1460	4.162 m	07°04.197 S	88°27.356 W
051/416	Recovering of FBOS 10	4.180 m	07°08.045 S	88°28.013 W
052/417	Hoisting of RK 105	4.174 m	07°07.812 S	88°27.882 W
053/418	Sidescan Sonar 4	from	07°04.286 S	88°34.703 W
		to	07°09.986 S	88°20.662 W
02-08-1992				
054/419	MC 346	4.165 m	07°04.222 S	88°27.400 W
055/420	MC 347	4.167 m	07°04.208 S	88°27.389 W
056/421	MC 348	4.176 m	07°05.018 S	88°26.985 W

02-09-1992

057/422	MC 349	4.179 m	07°04.989 S 88°26.955 W
058/423	KG 1461	4.179 m	07°05.010 S 88°26.957 W
059/424	KG 1462	4.178 m	07°05.001 S 88°26.969 W
060/425	KG 1463	4.177 m	07°05.026 S 88°26.975 W
061/424	Recovering of RK 105	4.174 m	07°07.812 S 88°27.882 W
062/427	Hoisting of FBOS 11	4.177 m	07°07.923 S 88°28.002 W
063/428	Trawl 8	from to	07°08.815 S 88°27.060 W 07°15.028 S 88°24.843 W
064/429	OFOS 27	from to	06°59.896 S 88°31.181 W 07°08.483 S 88°24.940 W

02-10-1992

065/430	KG 1464	4.154 m	07°04.384 S 88°26.724 W
066/431	KG 1465	4.161 m	07°04.380 S 88°26.790 W
067/432	KG 1466	4.159 m	07°04.380 S 88°26.740 W
068/433	Sidescan Sonar 5	from to	07°04.600 S 88°35.139 W 07°06°855 S 88°20.124 W

02-11-1992

069/434 070	MC 350 MOCNESS 2	4.157 m from to	07°05.981 S 88°26.997 W 07°03.600 S 88°27.700 W 07°03.482 S 88°26.907 W
----------------	---------------------	-----------------------	---

02-12-1992

071/435	OFOS 28	from to	07°04.850 S 88°26.860 W 07°07.077 S 88°27.931 W
072/436	Recovering of FBOS 11	4.177 m	07°07.923 S 88°28.002 W
073/437	Hoisting of RK 106	4.203 m	07°04.340 S 88°24.778 W
074/438	Hoisting of FBOS 12	4.162 m	07°04.646 S 88°27.637 W
075/439	MC 351	4.160 m	07°04.125 S 88°27.575 W
076/440	KG 1467	4.157 m	07°03.796 S 88°26.984 W
077/441	KG 1468	4.153 m	07°03.803 S 88°27.005 W
078/442	KG 1469	4.159 m	07°03.867 S 88°27.022 W

02-13-1992

079/443	MC 352	4.154 m	07°03.777 S 88°26.998 W
080/444	KG 1470	4.150 m	07°03.579 S 88°27.571 W
081/445	KG 1471	4.152 m	07°03.344 S 88°27.177 W
082/446	KG 1472	4.150 m	07°03.507 S 88°27.529 W
083/447	KG 1473	4.151 m	07°03.790 S 88°28.201 W
084/448	Recovering of RK 106	4.203 m	07°04.340 S 88°27.637 W
085/449	KG 1474	4.152 m	07°03.786 S 88°28.185 W
086/450	Hoisting of RK 107	4.189 m	07°04.283 S 88°24.620 W
087/451	KG 1475	4.159 m	07°03.673 S 88°28.685 W

02-14-1992

088/452	TRAWL 9	from	07°02.029 S 88°22.982 W
		to	07°04.975 S 88°22.576 W
089/453	MC 354	4.157 m	07°05.185 S 88°27.185 W
090	MOCNESS 3		station ceased
091/454	Recovering of		
	FBOS 12	4.162 m	07°04.646 S 88°27.637 W
092/455	MC 355	4.170 m	07°03.520 S 88°27.586 W
093/456	Hoisting of		
	FBOS 13	4.170 m	07°04.724 S 88°27.627 W
094/457	KG 1476	4.174 m	07°07.550 S 88°27.000 W
095/458	KG 1477	4.162 m	07°07.505 S 88°27.009 W
096/459	KG 1478	4.172 m	07°07.503 S 88°26.941 W

02-15-1992

097/460	KG 1479	4.188 m	07°07.492 S 88°26.985 W
098/461	KG 1480	4.162 m	07°07.534 S 88°27.008 W
099/462	KG 1481	4.167 m	07°07.515 S 88°26.998 W
100/463	Recovering of		
	RK 107	4.189 m	07°04.283 S 88°24.620 W
101	MOCNESS 4	from	07°04.600 S 88°25.800 W
		to	07°04.575 S 88°29.623 W
102/464	OFOS 29	from	07°02.770 S 88°27.219 W
		to	07°02.107 S 88°25.174 W

02-16-1992

103/465	KG 1482	4.160 m	07°04.436 S 88°27.849 W
104/466	KG 1483	4.151 m	07°04.394 S 88°27.983 W
105/467	KG 1484	4.153 m	07°04.387 S 88°27.819 W
106	MOCNESS 5	from	07°05.400 S 88°25.400 W
		to	07°06.229 S 88°23.660 W
107/468	MC 356	4.156 m	07°03.530 S 88°27.658 W
108/469	FBOS 13	4.170 m	07°04.724 S 88°27.627 W
109/470	MC 357	4.153 m	07°04.406 S 88°27.849 W
110/471	MC 358	4.151 m	07°04.353 S 88°27.839 W
111/472	MC 359	4.152 m	07°03.768 S 88°28.123 W

02-17-1992

112/473	OFOS 30	from	07°03.493 S 88°28.765 W
		to	07°07.151 S 88°24.096 W
113/474	Hoisting of		
	RK 108	4.146 m	07°04.340 S 88°32.496 W
114/475	MC 360	4.160 m	07°04.411 S 88°27.559 W
115/476	MC 361	4.163 m	07°04.453 S 88°27.621 W
116/477	MC 362	4.166 m	07°04.532 S 88°27.611 W
117/478	Hoisting of		
	FBOS 14	4.151 m	07°04.373 S 88°30.540 W
118	MOCNESS 6	from	07°05.200 S 88°30.500 W
		to	07°06.194 S 88°29.513 W
119/479	TRAWL 10	from	07°01.046 S 88°34.896 W
		to	07°04.163 S 88°32.205 W

02-18-1992

120/480	Recovering of			
	RK 108	4.146 m	07°04.340 S	88°32.496 W
121/481	MC 363	4.163 m	07°04.697 S	88°27.638 W
122/482	MC 364	4.165 m	07°04.457 S	88°27.581 W
123/483	MC 365	4.160 m	07°04.415 S	88°26.733 W
124/484	Hoisting of			
	RK 109	4.215 m	07°07.044 S	88°29.513 W
125/485	KG 1485	4.167 m	07°04.465 S	88°27.578 W
126/486	KG 1486	4.166 m	07°04.465 S	88°27.604 W
127/487	OFOS 31	from	07°04.456 S	88°31.345 W
		to	07°06.031 S	88°23.804 W

02-19-1992

128/488	KG 1487	4.178 m	07°07.780 S	88°27.008 W
129/489	KG 1488	4.166 m	07°07.539 S	88°27.037 W
130/490	Recovering of			
	RK 109	4.215 m	07°07.044 S	88°29.513 W
131/491	FBOS 14 Release attempt			
		4.151 m	07°04.373 S	88°30.540 W
132/492	KG 1489	4.167 m	07°04.438 S	88°27.570 W
133/493	KG 1490	4.163 m	07°04.444 S	88°27.576 W

02-20-1992

134/494	KG 1491	4.163 m	07°04.465 S	88°27.590 W
135/495	Multisonde 23	4.165 m	07°04.510 S	88°27.550 W
136/496	RK 110	Transponder defect - no hoisting!		
137/497	FBOS 14 Release attempt			
		4.151 m	07°04.373 S	88°30.540 W
138/498	MC 366	4.162 m	07°04.456 S	88°27.607 W
139/499	MC 367	4.153 m	07°03.793 S	88°28.228 W
140/500	OFOS 32	from	07°00.211 S	88°28.568 W
		to	07°09.517 S	88°27.395 W

02-21-1992

141/501	OFOS 33	from	07°03.336 S	88°28.728 W
		to	07°04.474 S	88°30.561 W
142/502	FBOS 14 Release attempt			
		4.151 m	07°04.373 S	88°30.540 W
143	MOCNESS 7	from	07°07.200 S	88°29.500 W
		to	07°09.605 S	88°27.741 W
144/503	KG 1492	4.163 m	07°07.477 S	88°26.967 W
145/504	KG 1493	4.168 m	07°07.504 S	88°27.007 W
146/505	TRAWL 11	from	07°03.852 S	88°27.572 W
		to	07°07.145 S	88°26.683 W

02-22-1992

147/506	Sidescan Sonar 6	from	07°00.007 S	88°27.553 W
		to	07°07.312 S	88°27.350 W
148/507	Nav.Trans. 18		07°05.628 S	88°27.422 W
149/508	FBOS 14 Release attempt			
		4.151 m	07°04.373 S	88°30.540 W

Berichte aus dem Zentrum für Meeres- und Klimaforschung - Reihe E

**Institut für Hydrobiologie und Fischereiwissenschaft (Hydrobiologische Abteilung)
Zeiseweg 9, 2000 Hamburg 50**

oder:

**Institut für Hydrobiologie und Fischereiwissenschaft (Fischereiwissenschaftliche Abteilung)
Olbersweg 24, 2000 Hamburg 50**

- 1. Röpke, A. (1992): Eine vergleichende Studie zur Vertikalverteilung von Fischlarven in Relation zur physikalischen Stratifikation der Wassersäule im nördlichen Arabischen Meer.**
- 2. Schriever, G. und H. Thiel (1992): Cruise Report DISCOL 3 / Sonne Cruise 77.**

Berichte aus dem Zentrum für Meeres- und Klimaforschung

An der Berichtsreihe sind folgende Institute der Universität Hamburg beteiligt:

Meteorologisches Institut (MI)
Bundesstr. 55, 2000 Hamburg 13

Institut für Meereskunde (IfM)
Troplowitzstr. 7, 2000 Hamburg 54

Institut für Hydrobiologie und Fischereiwissenschaft (IHF)
Zeiseweg 9, 2000 Hamburg 50

Institut für Geophysik (IfG)
Bundesstr. 55, 2000 Hamburg 13

Institut für Biogeochemie und Meereschemie (IfBM)
Bundesstr. 55, 2000 Hamburg 13

Verzeichnis der erschienenen Hefte:

1. Nellen, W., D. Schnack und B. Zeitschel (1988): Expeditionsbericht über die METEOR-Reise 5, Abschnitt 3. (IHF)
2. Moll, A. (1989): Simulation der Phytoplanktodynamik für die zentrale Nordsee im Jahresverlauf. (IfM)
3. Thiel, H. und G. Schriever (1989): Cruise Report DISCOL 1 / Sonne-Cruise 61. (IHF)
4. Legutke, S. (1989): Modelluntersuchungen zur Variabilität im Strömungssystem des europäischen Nordmeers. (IfM)
5. Sündermann, A. (1990): Die Anwendung von adaptiven Gittern in zwei einfachen Modellen für eine atmosphärische Rollenzirkulation. (MI)
6. Schriever, G. (1990): Cruise Report DISCOL 2 / Sonne-Cruise 64. (IHF)
7. Salge, U. (1990): Strukturelle und sedimentäre Entwicklung des Süd- Tasman- Plateaus: Eine seismostratigraphische Interpretation reflexionsseismischer Daten. (IfBM)
8. Peters, G. (1990): Untersuchungen über die Ursachen der Krankheitsanfälligkeit von unter Umweltstreß lebenden Fischen, durchgeführt am Beispiel der Arten Aal, Forelle sowie Steinbutt. (IHF)
9. Nellen, W. (1990): Working Report on Cruise No. 11, leg 3 of RV METEOR. (IHF)
10. Pfannkuche, O. et al. (1990): BIOTRANS - Biologischer Vertikaltransport und Energiehaushalt in der bodennahen Wasserschicht der Tiefsee. (IHF)
11. Tessmer, M.E. (1990): Seismische Modellierung unter Berücksichtigung der freien Oberfläche mithilfe einer spektralen Tschebyscheff-Methode. (IfG)
12. Bigalke, K. (1991): Interaktive Modellkopplung zur Berücksichtigung heißer Punktquellen in Gitterpunktmodellen und Einfluß der Kopplungsstufe auf die Immission. (MI)

13. Romeiser, R. (1991): Validation of the WAM Wave Prediction Model by GEOSAT Wave Height Data. (IfM) (in Vorb.)
14. Mihardja, D.K. (1991): Energy and momentum budget of the tides in Indonesian waters. (IfM)
15. Rhodin, A. (1991): Kaltfronten unter dem Einfluß der Reibung in der Grenzschicht und ihre Modifikation bei unterschiedlicher Bodenrauigkeit und Bodentemperatur. Numerische Simulationen. (MI)
16. Dorau, F. (1991): Eindimensionale Inversion bandbegrenzter Seismogramme. (IfG)
17. Sausen, R. (1991): Über die Verwendung von Korrekturverfahren in Zirkulationsmodellen. (MI)
18. Hennemuth, B. et al. (1991): FRONTEX 1989 - Meßergebnisse zu neun Kaltfronten (MI)
19. Kausch, H. [Hrsg.] (1991): Die Unterelbe - Natürlicher Zustand und Veränderungen durch den Menschen. (IHF)
20. Miranda-Alonso, S. (1991): A boundary-value inverse model and its application to the calculation of tidal oscillation systems in the Western South Atlantic Ocean. (IfM)
21. Manschke, A. (1991): Fernerkundung der Basistemperatur konvektiver Wolken über dem Ozean. (MI)
22. Frauenheim, K. (1991): Entwicklung einer Probennahmestrategie zur quantitativen Erfassung des Benthos. (IHF)
23. Pohlmann, T. (1991): Untersuchung hydro- und thermodynamischer Prozesse in der Nordsee mit einem dreidimensionalen numerischen Modell. (IfM)
24. Karbe, L.; Mädler, K.; Janski, B. [Hrsg.] (1991): Biologische Effekte von Schadstoffen und toxisches Potential von Wasser und Sediment in Elbe und Nordsee. (IHF)
25. Freter, H. (1991): Mathematisch-numerische Untersuchungen zu einer Integralgleichungsmethode für die Modellierung und Inversion seismischer Wellenfelder. (IfG)
26. Thiel, H.; Foell, Eric J.; Schriever, G. (1992): Potential environmental effects of deep seabed mining. (IHF)

Die Berichte aus dem Zentrum für Meeres- und Klimaforschung werden aufgeteilt in die Reihen

- Reihe A: Meteorologie
- Reihe B: Ozeanographie
- Reihe C: Geophysik
- Reihe D: Biogeochemie und Meereschemie
- Reihe E: Hydrobiologie und Fischereiwissenschaft
- Reihe Z: Interdisziplinäre Zentrumsberichte

