

A WAVE RECORDER FOR USE ON A SHIP IN THE OPEN SEA

by R. DORRESTEIN

Koninklijk Nederlandsch Meteorologisch Instituut, Netherlands

Summary

A device for recording waves in the open sea aboard a ship is described. Use is made of an accelerometer mounted on a raft which is connected with the ship by an electric cable. The accelerometer supplies a signal which corresponds essentially to the vertical acceleration of the sea surface. This signal is integrated twice and recorded aboard the ship.

A disadvantage of the described device in comparison with the British ship-borne wave recorder is the fact that not all equipment is within the ship and that the method cannot be used from a fast sailing ship.

Advantages are that the device is simpler and easily transferable from one ship to another, that the waves measured are not necessarily disturbed by the ship and that the frequency response is constant down to periods of about 1.5 seconds.

Some preliminary results are given.

1. Introduction

In order to meet the increasing need for reliable wave-observations in the open sea, a number of instrumental measuring methods have been developed. Several methods which use floating wave-poles with damped vertical motion have been developed in recent years in the U.S.A. [1]. They can give good results, but none of them can be used in severe weather conditions and none of them promises that it can be used on a routine-basis. The British ship-borne wave recorder described by Tucker [2], which is coming into increasing use in several countries, does meet these two demands, and the experiences obtained with it seem to be satisfactory. However, this instrument has also certain objections: it measures the waves quite near the ship's hull, so that the properties of these waves are affected by the ship to an unknown degree, and the frequency response of the instrument falls off not only for the longer but also for the short waves, and is uncertain. Moreover, the instrument is rather complicated and not easily transferable from one ship to another.

The British wave-recorder continuously combines measurements of pressure and vertical acceleration. The first measure-

ment yields information about the height of the sea surface with respect to the ship; the vertical acceleration of the ship is integrated twice so as to yield the vertical displacement of the ship itself. By a suitable combination of the outputs, the ship's movements are believed to be eliminated.

At least for use from stationary or slowly moving ships, it was thought a simpler device which, moreover, avoids some of the disadvantages of the British instrument, could be realized by using an accelerometer mounted on a light weight float, which can easily be lowered from the ship and remains connected with the ship by a cable. The output of the accelerometer, after a double integration, could then be recorded on board the ship. In this way, a simultaneous measurement of pressure would be superfluous. A description of such a device, together with some preliminary results, follows here.

2. Description

The essential part of the apparatus is an accelerometer of the capacitance type with electrodynamic feedback. Its measuring head is mounted on a square raft with sides of one metre and thickness 10 cm, consisting of a sheet of foam plastic with wooden plates on both sides, see fig. 1. The raft is connected with the ship by a long floating line, and the measuring head is electrically connected with an electronic apparatus on board the ship by a floating shielded cable with at least two conductors. This cable is kept sufficiently slack.

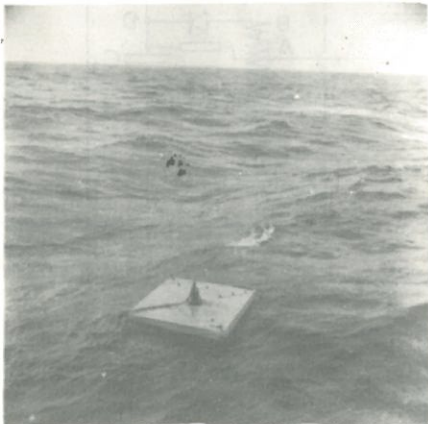

Fig. 1 The raft with the measuring head

PART 3

A block diagram is given in fig. 2, and within the measuring head a special network is found, as shown in fig. 3.

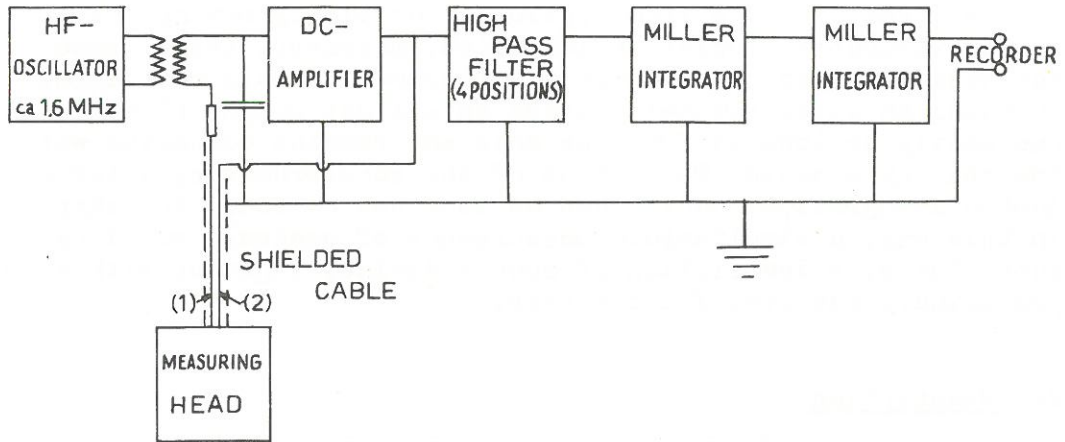

Fig. 2 Basic diagram

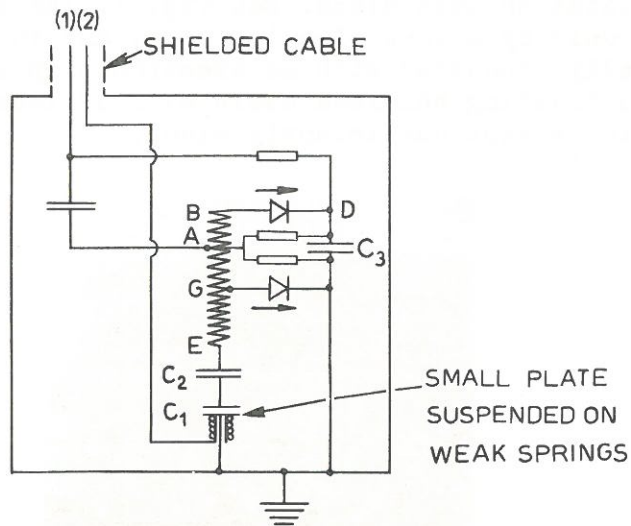

Fig. 3 Discriminating network with rectifiers within the measuring head

2.1 The measurement of acceleration

The measuring head has an aluminium cylindrical watertight casing. Its sensitive part is a small flat plate, mass 7 grams, which is suspended on weak springs, with its plane perpendicular to the cylinder-axis, and which is free to move in the direction of this axis. This plate forms a capacitor with a second plate at a distance of about 0.5 mm, which is fixed to the casing (but is electrically insulated from it). This capacitor, C_1 , is part of a circuit which is patented by Mr. S.L. Boersma of Delft, Netherlands (Neth. Pat. No 79541), see fig. 3. It works as follows.

The output of a HF oscillator is applied to the measuring head via the cable. The amplitude of this signal is unimportant, if being at least a few volts, but the frequency has to be very constant and is, therefore, thoroughly stabilized. Because of the diode between G and the casing in combination with a sufficiently large resistance between A and the casing, the coil BE will assume a positive DC potential which almost equals the amplitude of the HF voltage on G. In other words, the DC potential of the casing (which is zero) approximately corresponds to the minima of the potential of G. Similarly, point D which can have only a small HF signal owing to the capacitor C_3 and two resistances, will assume a DC potential which approximately corresponds to the minima of the potential of B.

Now, in the zero position of the movable plate of the capacitor C_1 , the frequency of the incoming HF signal can be tuned in such a way that the HF voltage across the coil AE balances that across the capacitors C_1 and C_2 . Then the voltage on A is approximately zero and the minima of the potentials of the points B and G are equal, so that the DC potential on point D will be equal to that of the casing: zero. If, however, by a displacement of the movable plate of C_1 this capacitance is increased a little, then, keeping the frequency constant, the HF voltage across the coil AE becomes larger than that across the capacitors C_1 and C_2 , and consequently the amplitude of the HF voltage on B exceeds that on G, the level of the minima of the potential of B becomes lower than that of G and a negative DC voltage is generated on point D. If, on the contrary, the capacitance C_1 is reduced, a positive DC voltage results. When the position of the plate of C_1 is varying with frequencies not exceeding a few cycles per sec, a similarly varying voltage is generated in the measuring head.

This slowly varying voltage is fed back over the HF conductor (1) of the cable to the electronic unit on board and is amplified by a DC amplifier. The amplified output current is fed back again by the other conductor (2) of the cable to the measuring head, passes here through a coil, which is attached to the movable

plate of C_1 and which is in a magnetic field. The resulting force acting on the coil drives the movable plate back, (nearly) to its normal position. Ultimately, a displacement of the movable plate of C_1 of one micron corresponds to an electro-dynamic force of ca 3 grams, the force exerted by the weak springs being very much smaller than this.

When the measuring head is in a vertical position and is accelerated in the vertical direction, the force necessary to accelerate the movable plate is supplied almost entirely by the electro-dynamic feedback system and the current flowing through conductor (2) of the cable is strictly proportional to the acceleration, up to an acceleration of $\pm 0,6 g \approx 6 m.sec^{-2}$. The proportionality constant is in our case $0.4 mA.m^{-1}.sec^2$. The important advantage of this arrangement is not only the linear relationship between acceleration and current, which is essential for the double integration of the signal, but also the fact that the proportionality constant is almost completely independent of the length of the cable and the amplitude of the HF signal.

The current flowing through conductor (2) of the cable, which measures the acceleration, yields a voltage of about 5 Volts. $m^{-1}.sec^2$, which can be read on a voltmeter and can be recorded if desired.

It is obvious that the frequency of the signal from the HF oscillator must be very stable. This is achieved by a special design.

2.2 The measurement of the vertical displacement of the water surface

If it were possible to maintain the accelerometer in a vertical position on the moving water surface, the height variations of the surface could be found by a double integration of the acceleration. In reality, however, it appears to be impossible to keep the floating accelerometer vertical, unless one would resort to some type of gyroscopic stabilization. Without this, the direction of the axis of the measuring head necessarily fluctuates when the waves pass, and it is not quite the true vertical acceleration that is measured. This complication was met with also when the British ship-borne wave recorder was developed and we can refer to literature [2] as for that. We fixed the measuring head in the centre of a square flat raft with sides of one metre, so that the axis of the head is always nearly perpendicular to the average water surface over

one square metre. It can be shown that the error in the acceleration signal is relatively small then. The annoying thing, however, is that this error is mainly proportional to the square of the slope of the raft. Therefore it has always the same sign, and contains a component which varies only slowly (in the rate, not of the slope itself, but of the amplitude, or the envelope of the oscillating slope). This makes it necessary, before performing a double integration, to cut off DC components and all low frequencies below a certain value. To this purpose, a high-pass filter has been introduced, consisting of two RC units, with feedback (in order to achieve an increased slope of the response-frequency curve). By switching in different capacitors, the period where the response has dropped to 90% of its maximum can be put at 4, 8, 11 or 16 seconds; the period where the response is 70.7% is, then, 6, 11, 16 or 23 seconds, respectively.

The low-impedance output of the filter is fed into a first integrator stage followed by a cathode follower. Then comes a second integrator with cathode follower output stage. Both integrators are Miller integrators, which are characterized by a simple feedback circuit for obtaining large effective capacitance [3]. The output signal is 45 volts for one metre height difference, which can be reduced to 15 volts per metre or 4.5 volts per metre. This signal can have an amplitude up to 40 volts and 15 milliamps, and is fed into a recorder. By means of a switch, the output stage can be connected directly with the first integrator if so desired, and in this case the once integrated acceleration signal, that is the velocity, can be recorded.

Between the filter output and the recorder connectors, still four separating RC networks have been inserted, two with 2.5 seconds and two with 18 seconds time constant.

The error in the phase angle of the double integrated signal is more important than that in the amplitude. The phase angle error increases with increasing period, and is 45 degrees for 4, 5.5, 7 or 9 seconds, respectively, according to the adjustment of the high-pass filter. The phase and amplitude errors for a sinusoidal motion of the measuring head have been determined by mounting the latter in a hanging position on a vertical cycle wheel, which can be rotated with different velocities.

Obviously, the raft hardly responds to very short waves with wave-lengths less than the dimensions of the raft. The response of the apparatus for these short waves has not yet

been measured, but it is believed from a theoretical consideration that the response will drop to 90% of the maximum for a (deep water) wave period of 1.6 seconds, and to 70.7% for a period of 1.3 seconds. Thus, with the largest capacitance in the high-pass filter, the frequency response of the equipment is essentially constant for all periods between 1.6 and 16 seconds.

The natural periods of the raft for heaving and pitching are both about 1.0 second, but these motions are strongly damped, and no complications need to be expected in this respect.

The view of the rather poor quality of most ship's mains as regards voltage and frequency variations, the various supply voltages for the apparatus have been stabilized carefully.

In the near future a simple device will be added which enables to record and to read directly an average or rms. height over a few minutes.

3. Handling of the equipment and preliminary results.

The raft with the measuring head weighs less than 20 kilograms and it is easy for two men on a ship's deck to put it over board and lower it onto the sea surface. When on a stationary ship or a lightship in the North Sea, the raft will soon float away with the tidal current as the connecting line or steel wire is paid out, the electric cable being kept sufficiently slack. When there has come a sufficient distance between the ship and the raft, so that the waves near the raft are no more disturbed by the ship and the raft is no more subject to sudden shocks from the line to the ship, the recording of the waves can begin. It has appeared profitable, in order to absorb shocks, to have a small floating drum on the connecting line at about ten metres from the raft. Another small drum which can be inserted between the line and the raft is found to be effective in preventing the raft from diving in strong currents, or when hauling it in.

Experience on anchored lightships has shown that the raft keeps its right position on the water surface in currents up to about 4 knots. It is hoped that, perhaps by an adequate profiling of the raft, the working range as regards currents can be extended so far, that it becomes possible to utilize the equipment from slowly moving ships.

Fig. 4 gives an example of parts from successive records of the acceleration, the velocity and the displacement signal, all taken within a time interval of less than 15 minutes, so that the state of the sea may be assumed to have been stationary.

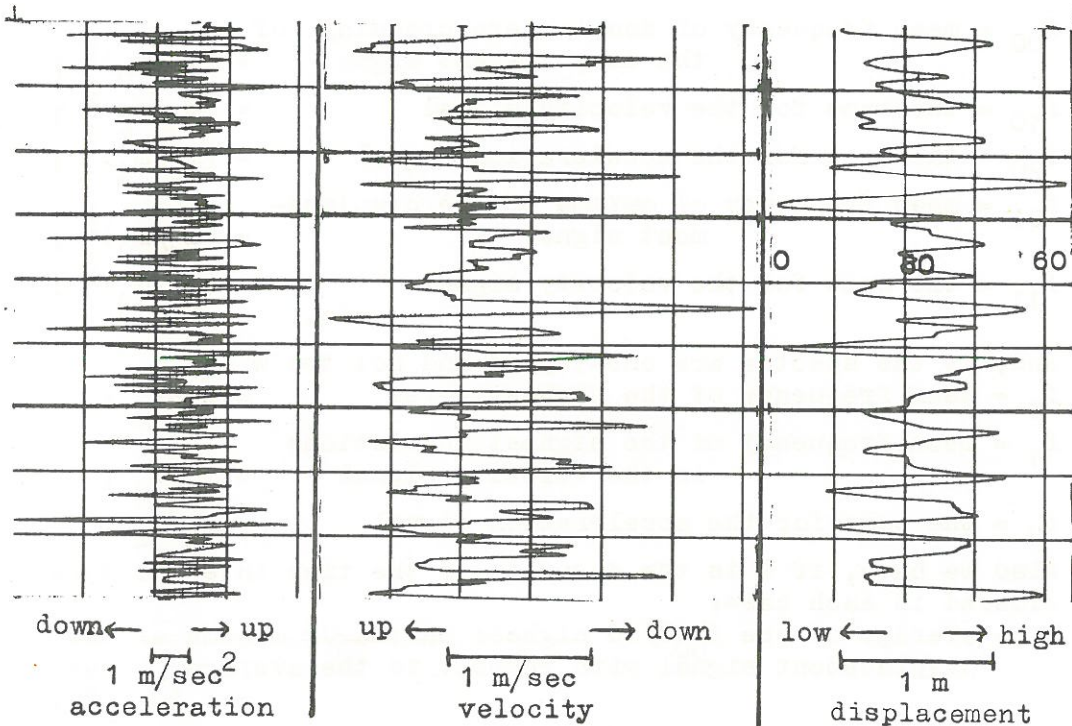

Fig. 4 Three 90 seconds samples of nearly simultaneous records of vertical acceleration, vertical velocity and vertical displacement of the sea surface (increasing time upward). Lightvessel "Goeree", pos. $51^{\circ}56'N$, $3^{\circ}40'E$, depth ca. 25 m. April 7, 1957, between 13.30 and 14.00 GMT. (High-pass filter with one but largest capacitance. Honeywell Brown potentiometer pen recorder).

In fact, in the place of observation and upwind from it over at least 100 miles, the wind has been approximately constant in direction (NNE) and in force (about 20 knots) during the previous 24 hours, so that the waves present may be assumed to approximate a fully developed sea corresponding to this wind velocity.

In fig. 4 the shift in the dominant frequencies from one signal to the other is clearly seen. Since no suitable equipment was available, no direct spectral analysis of the signals could be made. However, the first few moments of the displacement spectrum can be estimated easily from the records.

Putting $w(f)$ df the spectrum of the displacement signal, with the meaning that $\int_0^{\infty} w(f) df =$ mean square of height variation with respect to the average level, defining then the moments m_k by $m_k = \int_0^{\infty} f^k w(f) df$, and assuming that the theory of gaussian random signals [4] [5] is applicable, we have the following relations:

Nevertheless, reasonable estimates of the moments up to m_4 could be made. No attempt was made to compare the results⁴ with hypothetical spectra for fully developed sea as found in literature, because of the apparent great influence of the low period cut-off, at least on the acceleration signal, and since the waves under consideration are believed to be influenced substantially by tidal currents and by the coast and bottom topography.

Acknowledgement

The writer is indebted to many persons who have helped him during the development of the instrument. Especially, he expresses his thanks to Vice-Adm. (ret.) J.W. Termijtelen for his help and encouragement in the initial phase of the project, to Mr. S.L. Boersma who designed the electronics, for his cooperation, to Mr. H.J. Schoemaker of the Hydraulics Laboratory, Delft, for stimulating discussions, to Mr. H.J.A. Vesseur for valuable advices, to Mr. P.A. Kurth for his assistance during the experiments at sea and to the staffs and crews of the light-vessels for their interest and assistance.

The writer thanks the director-in-chief of the Institute for his permission to publish this paper.

References

1. H.G. Farmer, W. Marks, R.G. Walden, G.G. Whitney Jr., A technique for ocean wave measurements, Proc. First Conf. "Ships and Waves", 1955, 11-32. (contrib. No 746 from Woods Hole Oceanographic Institution).
2. M.J. Tucker, A wave recorder for use in ships, Nature 170 (4329), 1952, 657-659.
M.J. Tucker, A ship-borne wave recorder, Nat. Inst. of Oceanography, Internal Report No A2, 1954.
3. W.C. Elmore, M. Sands, Electronics, Mc Graw Hill Book Cy, Inc. 1949, p. 76.
4. S.O. Rice, Mathematical analysis of random noise, Bell System Tech. J. 23, 1944, 282-332 and 24, 1945, 46-156.
5. R.A. Wooding, An approximate joint probability distribution for wave amplitude and frequency in random noise, New Zealand J. Sci. Tech. B 36 (6), 1955, 537-544.

16759

CHAPTER 23A WAVE RECORDER FOR USE ON A SHIP IN THE
OPEN SEABY R. DORRESTEIND.E. CARTWRIGHT:

In spite of the great difficulty of measuring the two-dimensional spectrum of waves at sea, there is scope for much useful work with ship motions using a single stationary wave recorder, of which Mr. Dorrestein describes a good example. There are few enough types of recorder available for use in the open sea, and I think the author has justly assessed the relative merits of his own with the other two most well known types. At the N.I.O. we have also used the floating accelerometer principle in a buoy 5½ feet in diameter containing besides the accelerometer and integrating circuit, 2 gyroscopes for measuring the wave slopes and a micro-barograph for registering wind pressures on the sea surface. We found it preferable to have the complete electronic circuitry and recording mechanism inside the buoy, so that it could float freely without any cable attachment to the ship. (See "Engineering" vol. 181,

p. 398, May 1956).

I might mention that there are at least two alternative ways of measuring the vertical motion of a float without doubly integrating its acceleration. Both consist of an instrument suspended below the float by a cable long enough to reach below the practical limit of wave motion. The instrument may be a pressure recorder, or a freely rotating propeller whose total rotation is proportional to linear displacement. The latter principle has been used in the U.S.S.R. in the Morosov-Telyaev wave recorder, mentioned in Chapter 10 of these proceedings (Vosnessensky and Firsoff). The only account I have seen of this instrument is in: Perm. Int. Ass. Navig. Cong., 19th Congress, Sec. II, Communication 3, Ch. 14, London 1957.

J. DARBYSHIRE:

This instrument appears to have interesting possibilities and it would be useful to be able to compare its results with those given by the N.I.O. ship-borne wave recorder in moderate seas. It might then be possible to ascertain the effect, if any, of the presence of the ship on the wave measurements. I understand the British recorder is soon to be installed on a Belgian lightship and this should provide a suitable opportunity.

W. MARKS:

That wave poles are not adequate means of measuring the sea has become fairly obvious. In tests with such equipment (author's reference 1), we found that wave poles: were difficult to launch and retrieve (impossible in heavy seas), could not bear a sufficiently long sensing staff to be useful in high seas and had a natural period that affected the frequency-response of the system.

More important from the standpoint of this paper is that in one case the wave pole was fixed to the ship via a long cable mounted on floats. The float nearest the pole was sufficiently far away to permit the wire to sag in the form of a catenary. This allowed the pole to have the maximum amount of freedom possible under the circumstances. The differences in drift characteristics between the pole and the ship caused a strain on the cable which was transmitted to the pole. Unless the ship maintained slack on the cable, the pole responded to the external forces imposed on it through the cable and gave erroneous readings. This would seem

to make it impossible for use as a towed piece of equipment, even at slow speeds.

The answer to this problem is not to tow the raft but to let it ride free and telemeter the information back to the ship. The ship is now free to do what it pleases, the only disadvantage being that the instrument must be readily found and retrieved. If however, the instrument is expendable, it could be picked up when and if it were convenient.

Such an instrument is being designed at the Taylor Model Basin to be used in such full scale ship testing experiments where it is not feasible to attempt to retrieve the instrument. We are aiming for steady transmittal for eight hours and a range of twenty miles. Thanks to the pioneering efforts of the author, little difficulty is anticipated with the accelerometer - double integration aspects of the problem.

The housing for the sensing and telemetering instruments is another problem. The raft appears to be a rather unstable element which may be turned over in a heavy sea. We are considering a cylindrical container mounted inside a floating ring. The container has a very low center of gravity, to prevent capsizing, and the accelerometer is mounted on gimbals; to minimize tilt.

The above are by no means meant as criticism of the author's fine job. The basic system of providing a wave measuring device for all sea conditions and divorced from external disturbances is most praiseworthy. The most that can be done now is to provide additional conveniences, such as the above, to make the instrument more efficient.

H.J. SCHOEMAKER:

A typical feature of the wave-recorder of Dr. Dorrestein has not been mentioned explicitly in the description but deserves some attention: viz. the fact that the buoy, on which the accelerometer is mounted, follows the orbital motion in the waves.

As the most regular swell or the best, simple harmonic wave produced in a laboratory has a trochoidal shape, every wave recorder which does not follow this orbital motion gives an output as a trochoid in the waterlevel-time diagram. Harmonic analysis of such a diagram gives besides the apparent frequency also higher harmonics of appreciate amplitude.

The mathematical description of these waves in the first order approximation, however, in the coordi-

nates of Lagrange (Gertsner waves) give a good degree of accuracy by means of simple sine and cosine functions, cf. "Basic experimental wave research" by F. Suquet and A. Wallet in the Proc. of the joint meeting of the International Association for Hydraulic Research and the Hydraulics Division, American Society of Civil Engineers, Minneapolis 1953.

Due to the fact that the buoy of Dorrestein follows the orbital motion to a certain extent, the output of this recorder will be a sinusoid when the wave is a regular trochoid, of course, within the limitation of precision indicated by Dr. Dorrestein. Thus it must be emphasized that analysis of the recorded waves will differ from those recorded by a fixed-point recorder.

Probably the energy in the high frequencies regions indicated by various authors in the frequency spectra of recorded waves are exaggerated due to the somewhat artificial decomposition in pure sine waves in stead of a decomposition in trochoids, which is not feasible.

E.C. TUPPER:

The author is to be congratulated on his part in the development of this instrument. Other sections of this Symposium deal with the theory of ship motions and with model experiments, but no matter what may be discovered or demonstrated in these fields the final value of such work will and must be judged by the performance of the ship herself.

Unfortunately ship data is the most difficult to obtain not the least because the sea conditions cannot be controlled. If they cannot be controlled then they must be accurately recorded and thus an instrument such as that described becomes essential. The author has frankly discussed the advantages and disadvantages of his recorder as compared with others now available and other speakers have emphasized that the single recorder gives a picture of the surface movement at one point only and cannot indicate the directional qualities of the sea spectrum.

However, a start must be made somewhere and Admiralty Experiment Works have been working along somewhat similar lines on a recorder which takes the form of a free floating buoy about three feet high, 18 inches in diameter and carrying an accelerometer. To avoid errors due to the buoy's inclination to the vertical, the accelerometer is mounted on a gyro. The output from the

accelerometer is in the form of a varying inductance controlling the frequency of a transistor oscillator, the sonic tone from which modulates a small transmitter. By transmitting the signal to the ship the need for a connecting cable between buoy and ship is avoided.

Early tests have proved promising but detailed refinements are being considered, particularly in the accelerometer and radio link, to improve the accuracy of the overall system.

W.H. WARNSINCK:

Dr. Dorrestein is to be complimented for his work on this highly important subject, and can be congratulated getting records like shown in fig. 4. He and his colleagues earn, and will need, every kind of help wanted for their development, because on their shoulders rests the whole responsibility of success or failure of full scale observation.

The lovely futuristic picture of full automatic ships observations and corresponding analysis as Dr. Chadwick and Dr. Chang painted us in their paper 39 and during the Symposium discussions, will only lead to useful results if and when a 17-knots-ship-borne three dimensional wave recorder, giving directional spectra and short-crestedness, will be developed.

Ships logs are of no use for ship motion studies, and never will be, because no human being can estimate wave dimensions and spectra within say 25 per cent accuracy. Most estimates don't even reach below 50 per cent error.

AUTHOR'S REPLY:

First, I wish to thank various commentators for their kind compliments which are, of course, not deserved by me for a great part.

Mr. Cartwright has made some supplementary remarks concerning other principles for measuring waves in the open sea. The Russian wave recorder mentioned by him is also described briefly in: E. Bruns, Handbuch der Wellen der Meere und Ozeane (Second Edition, Berlin 1955). Unfortunately, the existing accounts of this instrument in Russian are not accessible in the Netherlands. I would much appreciate having a better impression of the advantages and disadvantages of this interesting instrument. The beautiful measuring buoy devised in the British N.I.O. undoubtedly will reveal

many characteristics about the interaction between sea and atmosphere. I am anxious to be informed about these results. This is, however, obviously an equipment for special research, while the much simpler instrument described in my paper is rather intended for use on a more or less routine base, as is the British ship-borne wave recorder.

Of course, I agree with Mr. Darbyshire's suggestion for utilizing opportunities for comparing the records of the British and of the Netherlands instrument. I might add that we are also planning a comparison, in a moderate sea, of the records of our instrument with the wave records of the fixed pole which is mounted by "Rijkswaterstaat" off the Netherlands coast (near Katwijk) in about 10 meters water depth.

Both Mr. Marks and Mr. Tupper point out the desirability of having the buoy which measures the accelerations of the water surface free from the ship, by omitting the connecting cable and telemetering the information from the buoy to the ship. Both, they report on progress in this direction made in the U.S.A. and the U.K., respectively.

In the electronical system devised by Mr. S.L. Boersma, which is used in the equipment described in my paper, the connecting cable is essential. I think this cable does not form a serious objection for vessels which are stationary (f.i. light-vessels), or steaming at a very low speed (up to 5 knots, say). A thin raft, especially if suitably profiled, of course can better be towed than a vertically floating wave-pole. But as I already admitted in my paper, it is most unlikely that it will be practicable to use a method with a cable from faster steaming ships.

So the results of the developments mentioned by Mr. Marks and Mr. Tucker can be expected to be most important and should be awaited with great eagerness by all persons interested in the full scale observation on the behaviour of ships in a seaway.

Mr. Schoemaker calls attention to a feature of the measuring method described in my paper, which might be interpreted as an essential theoretical advantage of this method. Due to the fact that the float more or less follows the orbital motion in the waves, a generalized harmonic analysis of the record is expected by Mr. Schoemaker to contain a lower amount of the undesirable higher harmonics produced by non-linearity, than will emerge by an analysis of the record of the

same waves by a fixed-point recorder. I think this argument is true. It must be stated, however, that, even in the case of an exactly periodical trochoidal wave in deep water and a freely floating thin raft which is small compared with the wave length and which follows exactly the slope of the water surface, the output of the instrument is expected to be not completely free from higher harmonics. This is due to the tilt of the accelerometer. It can be seen as follows.

Let the wave travel in the positive x-direction with the positive z-direction vertically upward, and let the vertical and horizontal displacements of a water particle at the surface be given by $\zeta = a \cos \omega t$, $\xi = a \sin \omega t$, where $2a =$ wave height, $t =$ time and $\omega = 2\pi$ times frequency. The accelerations, then, are $\ddot{\zeta} = -a\omega^2 \cos \omega t$, $\ddot{\xi} = -a\omega^2 \sin \omega t$.

The total acceleration of a water particle is determined by gravity and pressure gradient, the latter being normal to the surface for particles in the surface. Thence, for such particles the vectorial difference between acceleration and gravity is normal to the surface. Assuming that the floating accelerometer follows the same orbit as the water that it displaces, the extra-force which, together with gravity, moves the sensitive accelerometer system must be proportional to the same vectorial difference and must have the same direction. Since this vector is directed along the sensitive axis of the accelerometer (which is assumed to remain normal to the water surface), it is the acceleration "felt" by the accelerometer. The accelerometer thus "feels"

$$\begin{aligned} [(g + \ddot{\zeta})^2 + \ddot{\xi}^2]^{1/2} &= g \left[\left(1 + \frac{\ddot{\zeta}}{g}\right)^2 + \left(\frac{\ddot{\xi}}{g}\right)^2 \right]^{1/2} = \\ &= g \left[1 - 2(a\omega^2/g) \cos \omega t + (a\omega^2/g)^2 \right]^{1/2} = \\ &= g \left[1 - (a\omega^2/g) \cos \omega t + \frac{1}{4}(a\omega^2/g)^2 - \frac{1}{4}(a\omega^2/g)^2 \cos 2\omega t + O(a\omega^2/g)^3 \right], \end{aligned}$$

where $g =$ acceleration of gravity and $O(a\omega^2/g)^3$ represents oscillating terms of order $(a\omega^2/g)^3$ and higher.

After exact double integration of the terms and because of the relation $\omega^2 = gk$ with $k = 2\pi$ divided by wave length, the oscillating part of the result becomes:

$$a \left[\cos \omega t + \frac{1}{16} a k \cos 2\omega t + O(a k)^2 \right]$$

The same expression can be shown to result when considering "Stokes"-waves or similar waves on deep water for which

$$\begin{aligned} \zeta &= a [\cos \omega t + O(ak)^2] + \text{const. } t, \\ \xi &= a [\sin \omega t + O(ak)^2] \end{aligned}$$

The expression shows that the expected output for such waves still contains a second harmonic term. But the magnitude of this term is only $1/8$ h of the magnitude in the case of a fixed-point wave height recorder, which would give, for the same waves (cf. H. Lamb, Hydrodynamics, 1932, § 250):

$$a [\cos \omega t + \frac{1}{2} ak \cos 2\omega t + O(ak)^2]$$

As far as I know, it has never been proved mathematically that in the description of two or more superposed periodic ("regular") waves, with different periods and wave lengths in the same direction, the relative magnitude of the non-linear terms is lower when using Lagrangian coordinates than with Eulerian coordinates, but it seems reasonable to assume this. Then, though in practice the conditions posed in the above derivation are far from fulfilled, it is reasonable to expect that a generalized harmonic analysis of records of the instrument described will show less "false" higher harmonics than does an analysis of records of a fixed-point recorder.

Referring to Mr. Warnsinck's kind remarks I would like to give as my personal impression that a much faster progress in the wave measuring techniques from sailing ships at sea could be realized when somewhat greater (but still relatively small) numbers of men and amounts of money would be made available to this purpose. The matter for a great deal is one of experiment and technique, and not of new principles.

During the oral discussion of the paper some remarks were made by Mr. M. St. Denis and by Mr. W.J. Pierson, Jr. According to Mr. St. Denis one more advantage of the British N.I.O. ship-borne wave recorder with respect to that described by me would be that one could determine also directional spectra with the N.I.O. instrument. I think this cannot be maintained. The difference in this respect between the N.I.O. instrument and that described by me is only a quantitative one: the ship's speeds up to which one can go for measuring Doppler shifts of wave frequencies being about 10 knots and 5 knots, respectively. Mr. W.J. Pierson, Jr welcomed the instrument described as a new means for obtaining a lot of reliable wave data without much expense,

but he expressed uneasiness in that the peculiar, greatly uncontrolled, horizontal and turning motions of the accelerometer might introduce serious complications in the interpretation of the records, especially so for the steeper waves. As was shown above (remarks of, and reply to Mr. Schoemaker), exactly the same non-vertical motions of the accelerometer could be expected to exert a beneficial influence as well. For the time being I believe that the disturbances by such and other non-linear effects in the records of this instrument are, at any rate, not more serious than they are for most other wave recording devices, but the experiences still to be gathered must give the ultimate answer.