



# Rotors for wave energy conversion—Practice and possibilities

Andrei Ermakov  | John V. Ringwood 

Centre for Ocean Energy Research, Maynooth University, Maynooth, Kildare, Ireland

## Correspondence

Andrei Ermakov, Centre for Ocean Energy Research, Maynooth University, Maynooth, Kildare, Ireland.  
Email: [Andrei.Ermakov@mu.ie](mailto:Andrei.Ermakov@mu.ie)

## Funding information

European Union's Horizon 2020 research and innovation programme, Grant/Award Number: 851885

## Abstract

This review studies some of the existing ideas which create a fundamentally new direction for wave energy converter (WEC) development, obtaining energy from the elliptical motion of particles in water waves using a rotor. The review focuses on three main aspects of rotor-based WECs: experimental study of the developed prototypes, derivation and development of the mathematical models, and control effectors and philosophies for the proposed devices. The range of developed small scale prototypes and their experimental studies are presented. The shortcomings of the current mathematical and hydrodynamic models are identified, while an overview of the proposed and new possible control effectors and strategies is conducted. This allows us to see the state of the development of the different concepts and problems to be solved in bringing wave energy rotors to operational reality.

## 1 | INTRODUCTION

Wave energy is one of the few untapped sources of renewable energy that could make a significant contribution to the future energy system. Unfortunately, to date, none of the traditional devices which use buoyancy or diffraction wave forces have proven themselves to be commercially viable. This creates a motivation to develop new approaches to wave energy conversion. This review studies some of existing conceptions that creates a fundamentally new direction for for the development of WECs, obtaining energy from the elliptical motion of water wave particles using a rotor.

### 1.1 | Overview of cyclorotor WEC development

The idea of using a cyclorotor for wave energy absorption is more than 40 years old [1]. During this period of time, only a relatively small number of concepts were proposed, and prototypes built. The comparison of these approaches is challenging, because of the significantly various design and operational principles of the devices. Generally the developed rotor-based WECs can be separated into two groups:

- Horizontal cyclorotors which use controllable hydrofoils or rotational cylinders to generate lift forces (Rotating Wing [2], CycWEC [3], Wave Rotor [4]),
- Horizontal and vertical rotors of the complex design which interact with the wave particles creating constant motion. (Savonius rotor [5], Darrieus-Wells rotor [6])

Currently, no full scale prototype has been built or tested in the marine environment. Most of the devices exist only as mathematical-physical concepts, small prototypes tested in flumes and pools, or data from numerical tanks tests. Some of these WECs were inspired by mathematical-analytical models [2, 7, 8] of the promising physical effects. They are, in general, based on approximate calculations, with some authors obtained more than 90% energy absorption. Some cyclorotor WEC concepts are adapted from wind/air turbines, such as the Savonius [5, 9], Darrieus and Wells rotors [10, 11], for the marine environment. Despite some promising results, few devices have been developed beyond technology readiness level (TRL) 4 [12, 13].

Recent interest in new approaches to wave energy conversion and, in particular lift force and cyclorotor based WECs [14, 15], makes this review timely.

This is an open access article under the terms of the [Creative Commons Attribution](https://creativecommons.org/licenses/by/4.0/) License, which permits use, distribution and reproduction in any medium, provided the original work is properly cited.

© 2021 The Authors. *IET Renewable Power Generation* published by John Wiley & Sons Ltd on behalf of The Institution of Engineering and Technology

## 1.2 | Overview of appealing characteristics

A lift-based WEC couples with the waves through the lift force generated when the wave-induced fluid motion flows past a body, resulting in an asymmetrical flow pattern. This can be achieved using an asymmetrical shape, such as a hydrofoil [2, 8, 12, 16], or by inducing an asymmetry in the flow, for example by spinning the body [17, 18]. The generation of the lift force requires circulation around the body, and it is accepted that the lift force on the body is proportional and orthogonal to the relative fluid velocity, as well as being proportional to the circulation magnitude, which is the net flow around a body in a clockwise or anti-clockwise direction [19].

Thus, the rotor concept can produce unidirectional rotation, which increases the efficiency and reduces the cost of power extraction significantly when compared to other WECs that typically require rectification of an oscillating motion [20, 21]. Energy can then be extracted from this rotational motion in a more direct manner than the reciprocating motions of more traditional WEC concepts. This makes it possible to have direct connection to a standard electrical generator, and is a potential step beyond the current state-of-the-art for wave energy converters in terms of cost, reliability and power conversion efficiency.

Most traditional WECs are designed to work primarily at one or a limited range of wave velocities and frequencies with maximum efficiency; however, the re-configurable abilities of the cyclorotors can significantly expand the range of useful excitation [22]. One benefit of adapting the 'hydrodynamic gain' is to modulate the wave load on the device, in particular under high-power or extreme waves. For example, by changing the depth of submergence of the rotor, it is possible to avoid critical loads and continue energy production, without the need for a survival mode which severely impacts capacity factor [12, 23]. Another benefit is that the level of the wave power captured by the device can be tuned by implementing a control strategy for the wide range of control effectors which can be installed on the cyclorotor, including hydrofoils [12, 15, 16].

There are many benefits in using hydrofoil-based horizontal cyclorotor WECs [2, 3, 12]. One is the minimisation of hydrodynamic losses, due to reduction of the turbulence generated in the conversion process. Another benefit is that the hydrofoils can be operated at speeds greater than the flow velocity. Hydrofoil pitch angles can be adjusted in real time, allowing it to control the wave input into the system. In addition, the energy per mass ratio, for some of the proposed cyclorotor based WECs [24], exceeds that of all other WEC devices. This can significantly decrease the levelised cost of energy (LCoE), potentially putting wave energy into economic competitiveness with solar and wind energies.

Another research direction considers the development of relatively simple fixed shape rotors [5, 6, 25], which can supply basic energy independent of the sea states. These devices exploit omnidirectional flows and have high tolerance to variations in the wave frequency and wave propagation direction. This makes cyclorotor WEC classes, such as Savonius

or Darrieus-Wells rotors, very competitive. However, most of these fixed shape devices target energy generation from tidal flows, as well as waves.

## 1.3 | Overview of challenges

Generally, manufacturing of the composite structure of cyclorotor based WECs is a much more complex process, in comparison to traditional WECs (e.g. heaving buoy). The majority of the existing prototypes were developed by small groups of scientists. The limited research, and efforts, to articulate the LCoE for cyclorotor WECs show values that cannot be considered competitive, in comparison to solar and wind energy conversion technology [12, 13, 23, 24].

The complexity of the cyclorotor design, and the resulting complex hydrodynamic effects of wave-structure interaction, make it challenging to derive a reliable analytical mathematical model [2, 13]. The approximations which are often used for modeling the simple shape, such as a heaving buoy type device, cannot be directly applied for rotating blades or foils. For example, it is a challenging problem to estimate viscous losses or wave radiation for cyclorotor devices [13, 24].

The effort to derive a numerical model usually falters due to the computational difficulties of solving a high fidelity model [10, 12, 26–28]. Almost all relevant cyclorotor mathematical models were developed only for potential flow, monochromatic waves, and generally in a 2D environment. The experience from experimental tests of the small scale prototypes, in 2D flumes and 3D tanks, usually leads to significant alteration the original concept, in both size and design [12, 13, 24], indicating the disparity between model and experimental predictions.

Another identified problem is the significant fluctuation of the torque and rotational speed values for realistic panchromatic wave inputs [12]. This problem could be solved by the development of optimal control strategies, but the most optimal WEC design, most appropriate control effectors, and most effective control strategies still remain to be determined. Control strategies for this device also need reliable forecasts of hydrodynamic input which may require the installation of a radar or up-wave gauge [12, 24]. For this reason, some research groups work on the optimal design of rotors which do not depend on any information or intervention from weather forecasting, sensing, electrical and or mechanical control [5, 6, 25].

## 1.4 | Contribution of this review

Although a number of cyclorotor based devices were developed within the last 30 years, only a few efforts to review and classify these types of WECs have been completed.

A minor study in this area can be found in the PhD thesis of Nik Scharmann [12] from 2014. His thesis is focused on the development of a novel type of WEC, the wave hydro-mechanical rotary WEC (WH-WEC). The author introduced some of the existing horizontal cyclorotor based devices and

their unique energy conversion approaches, within a section dedicated to concept discovery and ranking. The range of the control effectors employed, and control strategies utilised, were observed. Although previous studies were presented briefly, this was a first attempt to gather together existing applications of cyclorotors to wave energy conversion.

A new classification of lift-based WECs, and their potential, was introduced by Folley and Whittaker [16]. The authors derive a concept classification scheme, which provides a method to support this analysis by grouping conceptually similar lift-force-based WECs together. They also consider a number of existing concepts and identify a method for generating the lift and the motion of the body, which can be a target for new types of WEC development. The horizontal cyclorotor concept, with hydrofoils, is identified as the most promising, and the authors derive a sub-classification of control methods for this type of the device.

The work reported in [16] provided the inspiration for the LiftWEC project [15] which is currently underway. One of the deliverables [29], developed within the LiftWEC project, compiles information on pre-existing lift-based WECs in the form of a literature survey, which provides direction to research efforts on preliminary LiftWEC configurations. It also outlines information relating to existing lift-based WECs, as well as a small number of other devices. Generally, this document [29] provides a brief overview of those devices which have been identified as most relevant to the LiftWEC project, focusing mainly on the most developed CycWEC concept [24].

Our review focuses on the three main aspects of rotor based WECs: experimental study of the developed prototypes, derivation and development of the mathematical model, and control effectors and methods for the proposed devices. The WECs are presented in chronological order, with equal attention given to each concept. The range of developed small scale prototypes and their experimental study is presented. The problems associated with the mathematical and hydrodynamic models are identified. An overview of the proposed, and possible new, control effectors and strategies is conducted. This allows us to see the state of development of different concepts and problems to be solved in bringing rotors to operational reality.

## 1.5 | Layout of review

This review is an effort to observe all the existing applications of rotors to wave energy conversion and reveal the most promising concepts and approaches.

The section Overview of prototype devices is dedicated to the historical overview of the development and evolution of the different rotor-based prototypes. This section presents the devices, their characteristics, the conditions and results of physical tests.

The section Mathematical models for rotors describes the evolution of the concepts which were assigned to different rotor based WECs, from purely analytical conception to complex numerical tank tests, which became available with the development of computational fluid dynamics (CFD) software. It cov-

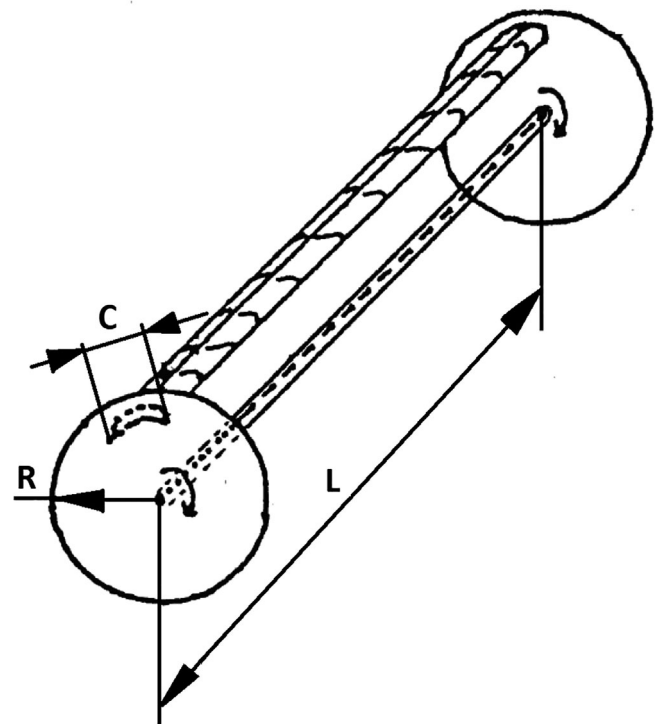

**FIGURE 1** The concept of a single hydrofoil cyclorotor—the Rotating Wing proposed by Hermans et al. [31]. Additional annotation has been included to define the operational radius,  $R$ , the span of the profile,  $L$  and the foil chord length,  $C$

ers the developed modelling goals and challenges, and various methods for presentation of the hydrodynamics and mechanical forces.

The section Control aspects of rotor based WECs is devoted to the control problems. Wave energy converters should be actively controlled to ensure maximum wave energy extraction and, in the rotor-based case, require more advanced control strategies. In this part, we consider the developed and proposed control algorithms, their objectives, and review all the control effectors, and their timescales of operation, that have been used.

In Perspectives and Conclusions sections, the general advantages and disadvantages of the rotor based WECs compared to the more traditional devices are discussed. The current state of development is reviewed, and the main challenges in the development of the technology and its potential for commercialisation observed.

## 2 | OVERVIEW OF PROTOTYPE DEVICES

### 2.1 | The rotating wing

The first prototype of the horizontal cyclorotor based WECs, illustrated in Figure 1, with a single hydrofoil operating in monochromatic waves, was developed by Hermans et al. [2, 30] in 1990. This device is based on a theoretical model of the fluid kinematics and lift force generation. In monochromatic waves,

the fluid velocity at any selected point in the water region can be presented as a vector that rotates at a constant angular velocity equal to the frequency of the wave. Initially, the fluid velocity vector at the axis location is directed at the hydrofoil. The rotation of this vector increases the hydrofoil's angle of attack, leading to generation of the lift force on the foil. It was noticed that the system will rotate with the wave frequency, until the axle load is greater than the torque created by the foil.

This device was tested in the deep water basin of the Maritime Research Institute, in the Netherlands (Figure 1). The prototype consisted of a submerged horizontal shaft aligned with the crest of the regular waves to which a single hydrofoil is attached. The operational radius  $R = 0.14$  m, the hydrofoil chord length  $C = 0.1$  m and the span of the profile  $L = 1.5$  m, were fixed. The submerged position of the cyclorotors centre and the angular velocity and angle of attack were manipulated variables. The experiments were conducted for monochromatic waves. It was shown, that the device rotates at the wave frequency and can absorb energy from waves.

This research was continued, under the supervision of A.J. Hermans, in the masters thesis of C. Marburg [32]. Another set of experiments [31] was conducted in 2007. The next experimental prototype had an operational radius  $R = 0.08$  m, a span  $L = 1.5$  m, a foil with thickness distribution according to NACA0015 [33], with a chord length  $C = 0.1$  m, and a camber of 0.022 m. The tests were set up in still water in order to verify the analytical conception. During this experiment, the wave elevations, foil position and shaft torque, for regular waves, were measured. Another set of experiments concern the application of the concept to a wave direction measuring device. The agreement between measurements of the wave direction, made by the device, and the analytically predicted theoretical wave directions was achieved.

Subsequent researchers [4, 8, 12] noted that it is difficult to imagine operating this concept in real panchromatic and multidirectional waves with current superposition and tidal effects. This research was discontinued, due to physical and numerical findings of poor conversion performance.

## 2.2 | The wave rotor

The idea of using a cyclorotor in wave energy conversion was proposed again, as a way to exploit the Magnus effect [18] in 1991. The 'Wave Rotor' developed by Retzler et al. [4, 7, 34] comprises two parallel contra-rotating cylinders in an orbital motion, as shown in Figure 2. These rotating cylinders can exploit the Magnus effect to create lift forces, which make contributions to the driving moment. The Magnus lift forces can be several times larger than the inertial forces. This provides the potential for a wave energy device of higher power, for a given displacement.

It was noted that Wave Rotor has the advantage that it is mechanically balanced, in comparison to the single hydrofoil concept. Lift forces on both cylinders make contributions to the driving moment, and these forces can be controlled by changing the rotational speed of the cylinders. The idea of keeping the

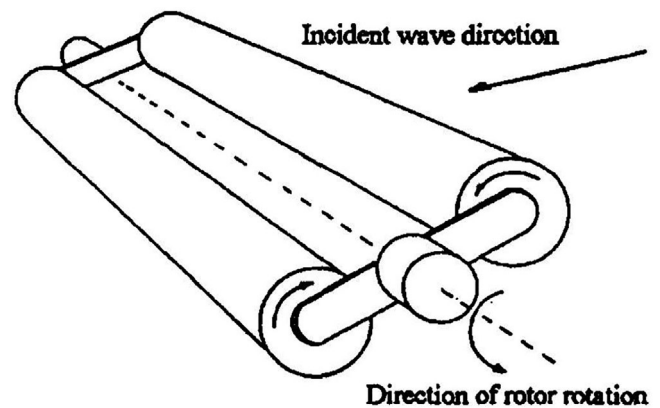

FIGURE 2 The concept of the Wave Rotor proposed [4] in 1995

rotor rotation in phase with waves, for maximisation of device efficiency, was also considered as the control strategy.

The developed prototype [23] consisted of two cylinders with radius  $r_{cyl} = 0.0175$  m and length  $L = 0.382$  m. Each cylinder was equipped with a motor, batteries, and a two-way radio controller, and is mounted between two end-disks with radius  $R = 0.08$  m, and bearings for the cylinder axles. It was tested in a flume of 12.8 m length, 0.425 m wide and 0.7 m water depth, in monochromatic waves with a frequency range of 0.5–2.0 Hz.

The experiment has shown that the wave rotor, as a wave absorber, demonstrated the expected synchronous rotation in regular waves, with power take-off (PTO) load held constant, the rotor phase lead over the wave flow increased with the wave size. However, difficulties with the control, partly due to the high inertia of the cylinders, were noted. The relatively low level of PTO load, about 5% of incident wave power, was explained by poor impedance matching, and can be expected to improve at full scale. Based on this experiment, the configuration of the Wave Rotor with a radius of  $R = 2.9$  m, and two cylinders  $r_{cyl} = 1.2$  m and spinning at 18rpm, was proposed. The efficiency of this device  $C_p = 0.15$  was assessed as the ratio between the absorbed power and the undisturbed wave power.

## 2.3 | The cycloidal wave energy converter—CycWEC

A new lift-based wave energy converter concept, namely a cycloidal turbine, was described in patent [8] in 2006 and then presented at a conference [35] in 2009 by Siegel et al. This was the beginning of the development of the CycWEC by the Atargis Corporation [14]. This device is based on the idea of complete Airy-type wave cancellation, using a horizontal cyclorotor with two hydrofoils. For optimal parameter selection, the model demonstrate the energy conversion efficiencies of more than 99%, from the incoming wave energy to shaft energy [3, 36]. During the next 10 years, its analytical and numerical models were developed, and experimental prototypes were built to use this promising effect.

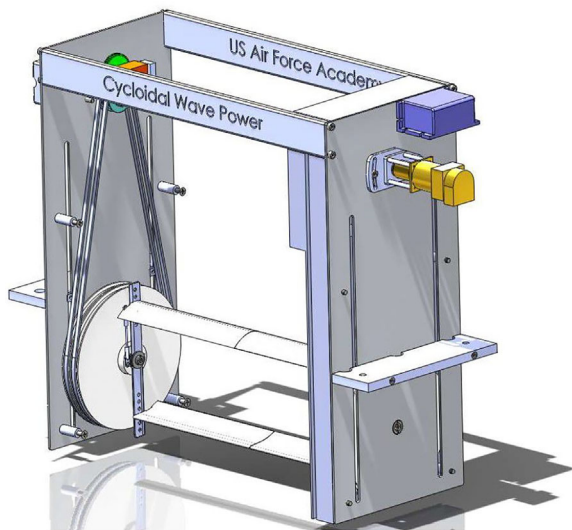

FIGURE 3 The first concept of the CycWEC [14]

The first 2D experiments, where the ability of the CycWEC to cancel irregular deep ocean waves were conducted for a 1:300 scale prototype, in a wave tunnel of the US Air Force Academy [37–39] in 2011. The studied CycWEC consisted of two hydrofoils attached equidistant to a shaft that is aligned parallel to the incoming waves (Figure 3).

The experimental setup had a radius  $R = 0.06$  m, and a NACA 4 series [33] hydrofoil of  $C = 0.05$  m chord length, with a camber line curvature to match the radius of the circle on which it rotated. This hydrofoil model should represent the similar NACA0015 [33] in straight flow, when rotating around a shaft. In this experiment, the CycWEC was tested in a superposition of two harmonic waves, and irregular waves from a Bretschneider spectrum. Wave cancellation efficiencies of approximately 80% were achieved for wave periods in a range of 0.4–0.75s, and heights of 0.02 m.

The second set of wave cancellation experiments for 1:10 CycWEC model was conducted in 2012 in a 3D wave tank at the Texas A&M Offshore Technology Research Center [13, 40]. The tested prototype had a radius of  $R = 1$  m, a span of  $L = 4.5$  m and hydrofoils NACA0015, with a chord length of  $C = 0.75$  m. These experiments targeted a collection of information in order to design a full scale CycWEC for a North Atlantic wave climate. These tests advanced the TRL of the CycWEC from 3 to 4 and established successful electricity production for the first time. New concepts for a WEC farm, such as two CycWECs mounted on a monopile Figure 4, and a free floating cluster of 5 CycWECs Figure 5, were proposed.

The experimental data obtained from these CycWEC experiments enabled the assessment of the influence of radiation and viscous losses. The experimental modelling [13] indicated that, ‘while the CycWEC avoided losses due to up-wave radiated waves suffered by typical symmetric point absorbers, it could nonetheless leverage the benefits of diffraction induced wave focusing at small span to wavelength ratios’. This data permitted an improvement in the development of the 3D numerical model. It also suggested significant changes to the proposed

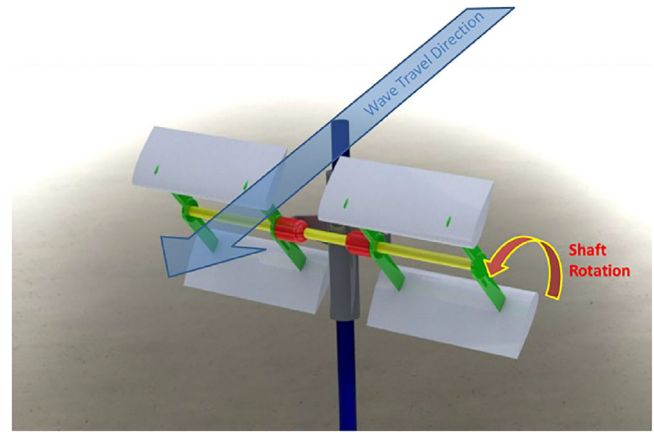

FIGURE 4 The concepts of the two CycWECs mounted on a monopile [13]

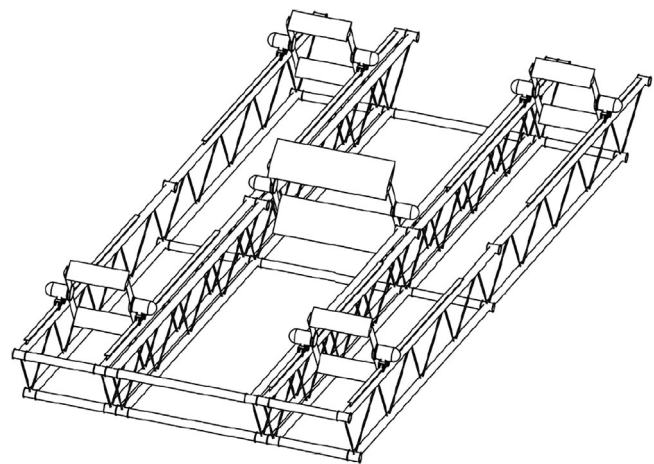

FIGURE 5 The concepts of the CycWEC farm [13]

devices’ size and design. The analytically established inviscid optimal device radius, that purported to provide the most shaft power  $2R/\lambda = 1/\pi \approx 0.32$  (where  $\lambda$  is the wave length), was changed to a significantly smaller WEC size  $2R/\lambda \approx 0.1$ . Thus, the most recent CycWEC concept, presented in 2019 [24], has the following parameters, as given in Figure 6.

## 2.4 | The wave hydro-mechanical rotary WEC—WH-WEC

The idea of using a rotating lifting surface in a monochromatic wave and exploiting the resulting generated lift forces, presented in the works Siegel et al. [3, 54], inspired a topic of the PhD research of Nik Scharmann [12] at the Technical University of Hamburg. From 2009 to 2015, the author developed a novel type of WEC, the wave hydro-mechanical rotary WEC (WH-WEC), covering technology readiness levels from 1 to 4.

For the first step of the project, concept validation of a two-foil NACA0015 rotor in monochromatic waves was conducted. The rotor had a radius  $R = 0.3$  m, chord length of  $C = 0.3$  m,

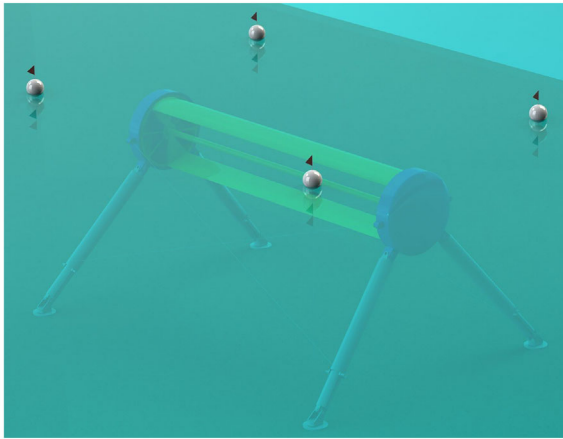

Property	Value	Unit	Operational State
Rotor Diameter	12	m	All
Hydrofoil Span	60	m	All
Hydrofoil Chord	5	m	All
Number of Foils	2		All
Displacement	375	$m^3$	Operational and Survival
Characteristic Mass	420	tons	All
Surface Area	2883	$m^2$	Operational
Submergence	12	m	Operational
Submergence	21	m	Survival
Submergence	-8	m	Maintenance
Nominal Generator Power	2.5	MW	All
Water Depth	40+	m	All

FIGURE 6 The most recent concept of the CycWEC [24]

span of  $L = 1$  m, submerged depth measured from still water line to radius of 0.13 m. The experiments were conducted in the Hamburg Ship Model Basin, Germany. The absorbed power is calculated by direct measurement of the generator torque and speed. It was shown that, for monochromatic and panchromatic waves, such a two foil rotor will have highly fluctuating torques, since the condition of orthogonality between rotational and wave particle velocities cannot be held without allowing discontinuous rotor position set-values. This would make efficient conversion from mechanical power to electrical power demanding. It was concluded that these effects can be mitigated by using a foil count  $> 2$ .

Based on these initial experiments, numerical modeling for cyclorotors with 3, 4, and 5 hydrofoils was conducted, and a four-foil, with fixed pitch, concept was selected. During the next physical experiments, the four-foil rotor with the same radius  $R = 0.3$  m and chord  $C = 0.3$  m NACA0015, for three different submergence depths, in monochromatic waves, was tested. It was found that the optimum rotor speed ratio, for wave states ( $H_s = 1.5$  m,  $T_e = 8.5$  s) at the low energetic region, at  $r_{s,min} \approx 0.3$ , and at  $r_{s,min} \approx 0.8$ , for wave states ( $H_s = 7.75$  m,  $T_e = 12$  s) at the upper region. An optimal operational depth of 8.6 m was determined.

Based on the experimental and numerical simulation conducted in Scharmann's thesis, a number of possible concepts for full scale wave energy converters, for different ocean regions, was presented. Their performance, and generated energy prices, were approximately estimated. However, the author prioritised the concept for a four-foil rotor with fixed pitch, as shown in

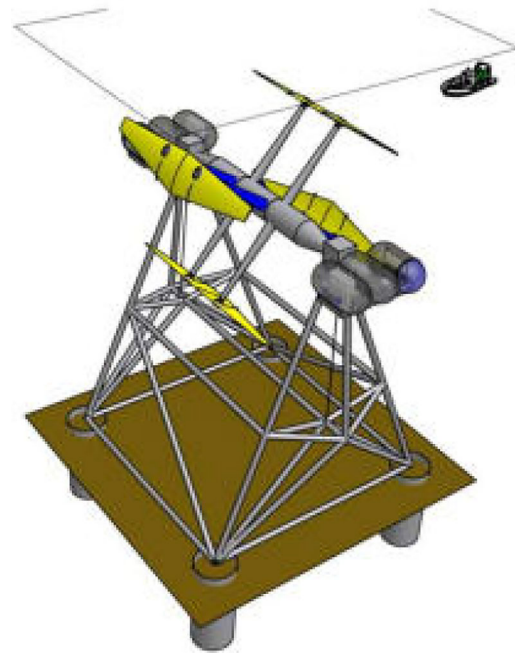

FIGURE 7 The concept of the WH-WEC proposed in [12]

Figure 7. A straightforward robust control strategy was proposed to keep the rotor in phase with upcoming waves. The rated power for this WH-WEC was estimated at  $\approx 800$  kW, which lies in the lower range of wind turbine technology, for comparison.

## 2.5 | The continuous rotational hydrofoil concept

A significant analysis of lift-based wave energy converters and their potential was subsequently conducted by Folley and Whitaker [16]. A classification was developed, based on the specific method of generating the lift, and the motion of the body.

The concept of lift-based wave energy converters that use a hydrofoil and continuous motion is identified as currently the most promising, as illustrated in Figure 8. The authors propose a range of methods for controlling the rotation and circulation of the device, for operation in irregular waves. The paper concludes with a discussion of potential developments in this area. The work reported in [16] provided the inspiration for the LiftWEC project [15], which is currently underway.

## 2.6 | Savonius-type rotors for wave energy

A number of different research groups studied the application of Savonius-type rotors for wave energy conversion. It has a fixed shape and can be controlled only via the PTO torque applied to the main rotational shaft. This rotor does not use lift forces to generate a driving torque; rather, it targets wave-induced water particle velocities to extract energy. Research in this area [5, 26, 41, 42] targets finding the optimal blade



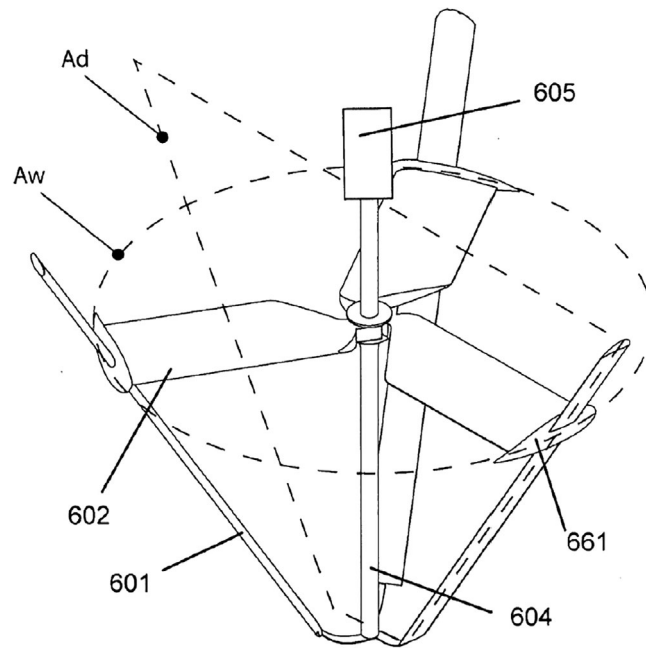

FIGURE 12 The Darrieus-Wells Rotor patented by Scheijgrond [6]

weight. The authors derived an analytical model and tested this concept in a 2D simulation in OpenFOAM. The radius of the modeled turbine was  $R = 0.1$  m, while the chord length of the bucket is  $C = 0.1$  m. The calculations were made for monochromatic waves only. A relatively poor efficiency coefficient of 3.57% was reported, in comparison to other existing WECs.

## 2.7 | Vertical-axis cyclorotors for wave energy

Proposed concepts for vertical rotors for wave energy conversion usually have a complex design. Thus, the Darrieus-Wells Rotor of Figure 12, which was numerically and experimentally studied by Ecofys [11] and later patented by P. Scheijgrond in 2009 [6], consists of two different types of rotor attached to a single vertical axis. A Darrieus rotor, with approximately vertical blades, is used to extract energy out of the horizontal water particle motion induced by the waves, while a Wells rotor, with horizontal blades, is used to extract energy from the vertical water particle motion induced by the waves. Subsequently, Ocean Mill [44] obtained an exclusive global licence on the Darrieus-Wells Rotor technology from Ecofys. They built a 1:2 scale prototype 30kWp (kilowatts peak) C-Energy demonstration device, with  $R = 2.5$  m and depth  $L = 5$  m, at Westerschelde, Netherlands. The turbine has a 30kWp rated generator. However this type of rotor targets tidal, as well as wave, energy.

Other designs for vertical rotor based WECs follow a simplifies philosophy that avoids the reliance on any information or intervention from weather forecasting, sensing, electrical and or mechanical control. For example, a number of

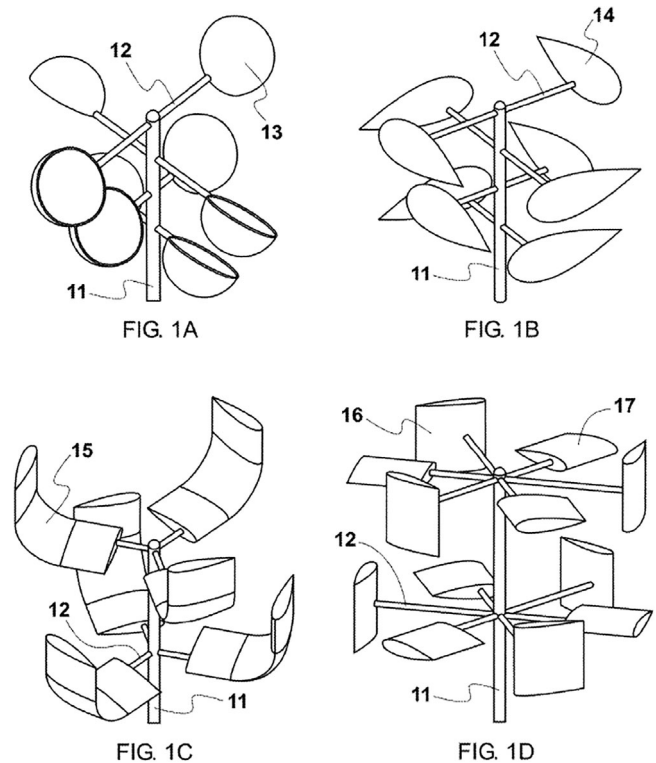

FIGURE 13 Vertical-axis unidirectional cyclorotors for wave energy conversion patented by Yang [25]

vertical-axis rotor concepts were presented in the articles of Yang et al. [10, 25, 45–48]. These rotors have a number of cup blades or curve hydrofoils, as shown in Figure 13. Driven by omnidirectional flows, these rotors perform unidirectional rotation about their vertically oriented shaft. However, though there is decreased reliance on external/sensory information, the mechanical designs are correspondingly more complex.

Experiments performed by Yang et al. [45, 46] were conducted in a wave flume of length 15 m, width 1 m and depth 1.3 m and involve moving the rotor in still water to simulate waves. A responsiveness comparison between a drag-type rotor Figure 13A and lift-type Figure 13D was conducted in [46]. The variations between the NACA0035-nose cups and NACA0021-35 hydrofoils were tested. The Hemi-30° from the drag type, and NACA0021-cambered, from the lift-type were selected as the best performing. It was noticed that the lift-type rotor rotated 5.7 times faster than the drag-type rotor.

The test results of the drag-type rotors were published in [45] and, for lift-type rotors, in [47, 48]. Experimental results have demonstrated unidirectional rotation of the rotors, but with noticeable fluctuations in angular velocity. A parametric study conducted by Yang et al. further revealed relationships between the rotor's mean angular velocity and rotors and waves parameters, giving some design clues.

### 3 | MATHEMATICAL MODELS FOR ROTORS

#### 3.1 | Rotor modeling using analytical approaches

The first physical-mathematical model developed for a single hydrofoil horizontal cyclorotor WEC by Hermans et al. [2], assuming that at a specific moment  $t$  the fluid velocity  $\hat{\theta}(t)$  makes an angle  $\alpha(t)$  with the hydrofoil profile, the lift force can be calculated as:

$$L(t) = \pi\rho|V(t)|^2R \tan(\alpha(t)). \tag{1}$$

The mechanical model of the cyclorotor is based on the balance equation for angular moments:

$$I\ddot{\theta} = L(t) - M \tag{2}$$

where  $I$  is the moment of inertia,  $V(t)$  is the relative fluid velocity, and  $M$  the external moment applied to the rotor's shaft. For this model, a linear damping moment is considered of the form  $M = \tilde{M} + \beta\dot{\theta}$ . The hydrodynamic model is based on two-dimensional linear potential theory and only the case of monochromatic waves is studied. Based on this analytical model, the formulae which calculate the averaged energy, absorbed by the device over one rotational period were derived.

The analytical model of the 'Wave Rotor' studied by Retzler et al. [4] was also developed for monochromatic waves. The authors derive the complex potential for the potential flow around the two parallel moving and spinning cylinders. The potential satisfies the linearised free surface and infinite fluid conditions. Based on this, the analytical formulae for the mean moment, generated by rotating cylinders on the cyclorotor shaft, are estimated. An equation for the energy (amplitude) of the transmitted, and radiated waves, is derived.

The influence of the submergence depth of the Wave Rotor on the mean moment was also analytically assessed in Figure 14, while the maximum 2D efficiency of the Wave Rotor for specific conditions is calculated as 98%. However, it was noted that, significant power is lost near the surface in the generation of radiated waves, and it will require very high rotational speeds to operate in greater depths with the same efficiency.

In the earlier numerical models developed for CycWEC [3, 36], a two-dimensional potential flow, with linear Airy waves, simulation is used. The hydrofoils are modeled as a point-source vortex using a complex potential [19], or discrete vortex panel [49]. The model used discrete numerical integration, with time and wave numbers as variables of integration, to solve for the flow potential induced by the point-vortex source terms representing the moving foils. The influence of design parameters such as device size, submergence depth, and number of hydrofoils on the performance of the converter was evaluated (Figures 15 and 16). The simulation conducted with optimal parameters demonstrated the conversion of more than 99% of the wave energy into the shaft energy. In subsequent studies

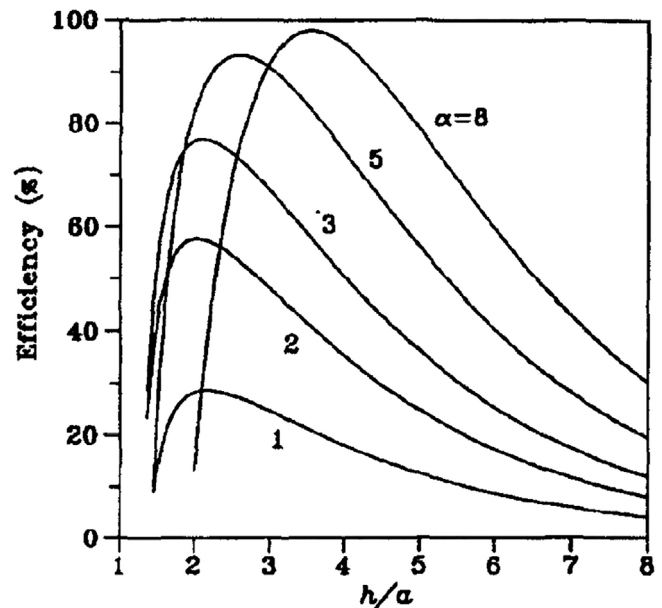

FIGURE 14 The theoretical Wave Rotor efficiency as a function of the cylinders spin speed  $\alpha$  and the ratio between depth  $h$  and rotor radius  $a$  [4]

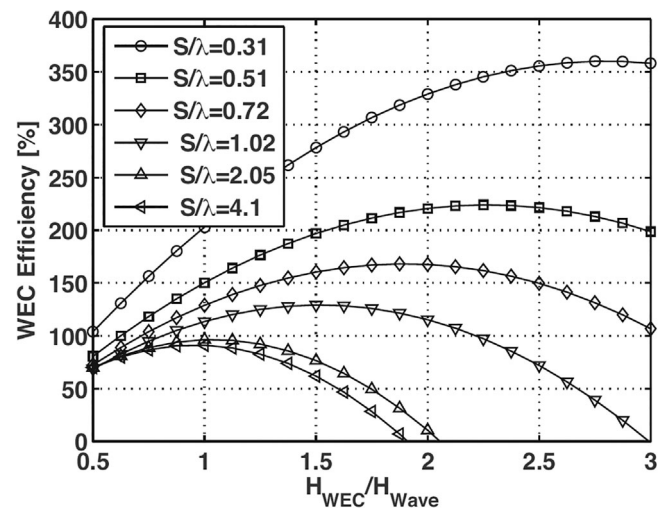

FIGURE 15 Wave cancellation efficiency of CycWEC and WEC wave height presented as a function of the ratio between incoming wave height and centre height of the WEC generated wave for different span to wavelength ratios.  $T = 2.5$  s. [24]

[50, 51], a Bretschneider spectrum is used to model irregular waves in simulation.

Later, the original model was complemented by a three dimensional radiation model, which is based on the experimental data obtained from the wave tank experiments [13] conducted in 2012. It has allowed the quantitative estimation of the three dimensional radiation efficiency. The authors used a control volume approach, balancing the known incident wave energy entering the control volume with that leaving the control volume, where the CycWEC device is modelled by the application of a representation of its radiated wave field. The mismatch between the wave energy entering and leaving the

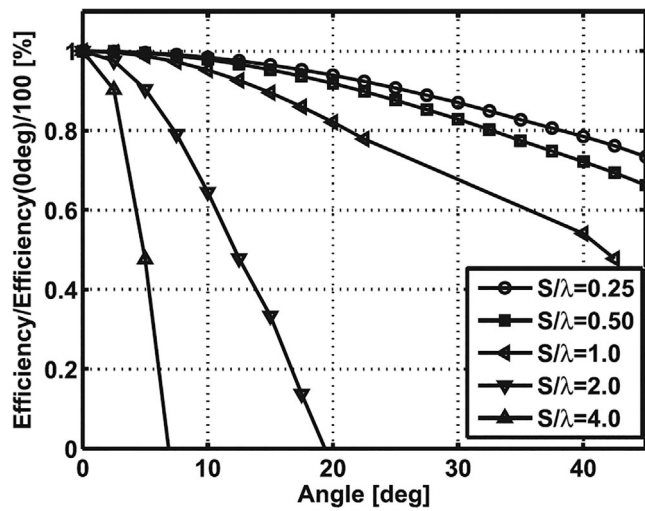

FIGURE 16 Dependence between efficiency and angle between WEC and wave crest, for various span to wavelength ratios [24]

control volume was assumed to be representative of the energy extracted by the CycWEC system. This updated model was used in subsequent studies [13, 28, 52, 53]. For example, the updated model was applied in the assessment of two cyclorotors arranged symmetrically on a common shaft in [52, 53] and the impact of a gap between the left and right blade, of a double cycloidal wave energy converter configuration on radiation efficiency, was investigated.

The influence of directionality of the incident wave train, on the efficiency of a CycWEC device, was considered in [52, 54]. The authors note that an increase in the misalignment of the WEC, relative to the incident wave crest, results in a decrease in the performance of the WEC. The severity of the decrease in performance intensifies with WEC span, such that larger devices suffer significantly greater reductions in performance as a result of the mismatched phase of lift generated across the extent of the hydrofoil.

Operation of the CycWEC for an actual ocean wave climate based on the data recorded by a buoy off the north-east shore of Oahu/Hawaii, was assessed in [55]. In this work, an optimal design, which could convert 40% of the incoming wave energy for the studied climate, was proposed. In the most recent publication, the CycWEC was investigated using numerical simulation, which includes 2D wave radiation and viscous losses with correcting value for 3D effects. [24]. Based on this numerical workbench, the overall annual mean absorbed power, and the total annual absorbed energy were predicted, as shown in Figure 17.

### 3.2 | Rotor modeling using commercial software

Some studies assess the performance of a cyclorotor concept by relying on engineering software such as ANSYS [56, 57] or OpenFOAM [58].

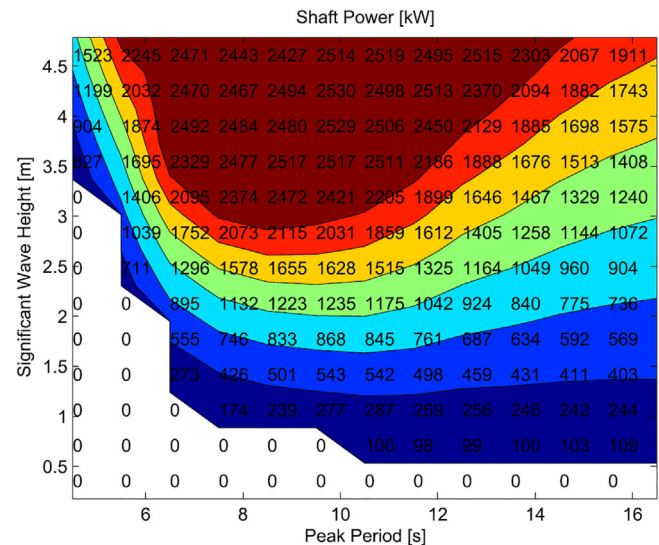

FIGURE 17 Power matrix for a CycWEC with radius 6 m, chord length 5 m and device span 60 m [24]

A 2D numerical model of the wave generation and cancellation properties of CycWEC were studied in the masters thesis of Caskey [27], using ANSYS (2014). This work was conducted in collaboration with Atargis. The model studied was based on the unsteady Reynolds-averaged Navier Stokes equations. The author used the volume of fluid method to determine the free surface fluctuations. A special grid was used to model the complex viscous flow field, non-linear free surface interactions and viscous effects, and the program modelled. This model could numerically predict the shaft torques, along with complete velocity and pressure fields. A power coefficient of  $C_p = 0.827$ , for the average wave energy converted to shaft power, was assessed.

A significant finite element numerical analysis of the hydrodynamic models for the WH-WEC concept was carried out in the PhD thesis of Nick Sharmann [12], using ANSYS CFX and OpenFOAM, for wave-hydrofoil and wave-structure interaction. Due to the very high computational costs of the virtual models, almost all simulations are done in 2D. To get data on operational modes dominated by 3D effects, scaled model tank tests were conducted.

Most of the numerical simulation used OpenFOAM, using the potentialFreeSurfaceDyMFoam solver. It is a single-phase solver, which solves certain free-surface flow problems. It is based on PIMPLE Foam, which is the large time-step transient solver for incompressible flow [58]. The free surface is modeled as a pressure boundary condition. All simulation is performed using monochromatic waves, characteristic of the nominal Northern North Atlantic sea state. ANSYS CFX was used only for cross virtual validation for the 2D case, or in the case when multiphase simulation is required. It was shown that ANSYS and OpenFOAM predict very similar results. The goal of the numerical simulation was optimisation of the hydrofoil profiles, and the determination of an optimal parameter set for the rotor to maximise  $C_p$  (see Figures 18 and 19).

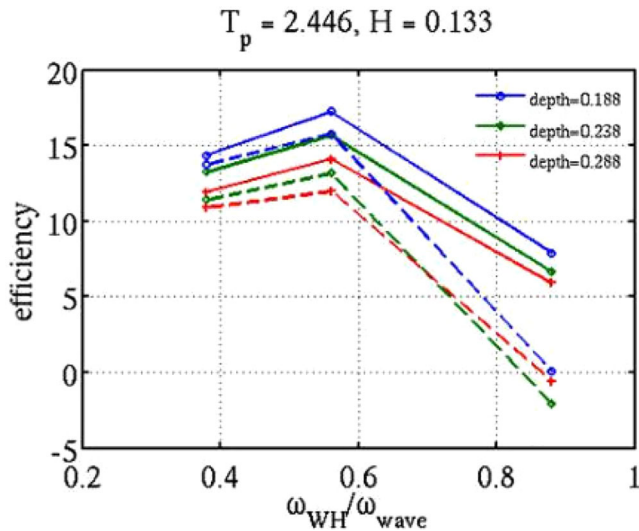

FIGURE 18 Comparison between numerical (solid lines) and experimental (dashed lines) results for WH-WEC [12] for a four-foil rotor with  $R = 0.3$  m using a Jonswap spectrum, where  $\omega_{WH}$  is the rotational frequency of the rotor, and  $\omega_{wave}$  the wave frequency

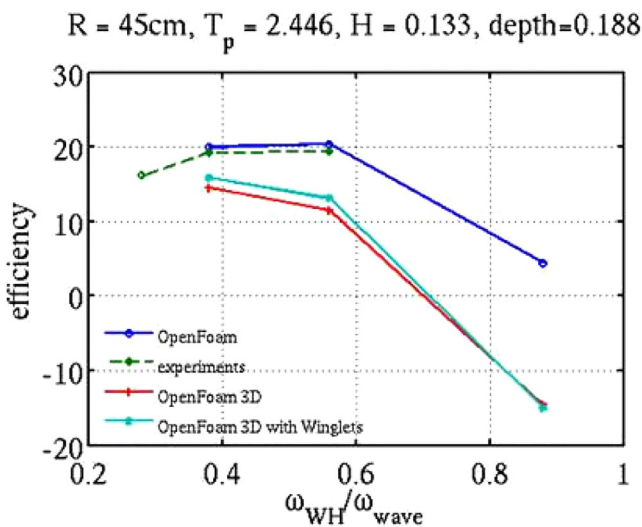

FIGURE 19 Comparison between experiments, and 2D and 3D simulation, for WH-WEC [12] with  $R = 0.45$  m

The 2D numerical finite element ANSYS model of Savonius rotors in viscous, turbulent and unsteady flow was studied in [42]. Subsequently, the same authors presented their 3D model in ANSYS [26], using the Reynolds-averaged Navier Stokes equations (RANSE). Siemens NX6 software [59] was used for solid modeling. The free surface was modeled using the volume of fluid (VOF) method. One of the goals of the simulations was to find the optimal angles between the tangent to the advancing edge and the line of motion Figure 20.

The concept of ‘a single-bucket drag-type cross-flow turbine’ (see Figure 11), proposed by Akimoto et al. [43], was tested in 2D simulation in OpenFOAM. The authors used the waveDyM-Foam solver which is a combination of pimpleDyMFoam (a solver for unsteady multi-phase flow with dynamic mesh treat-

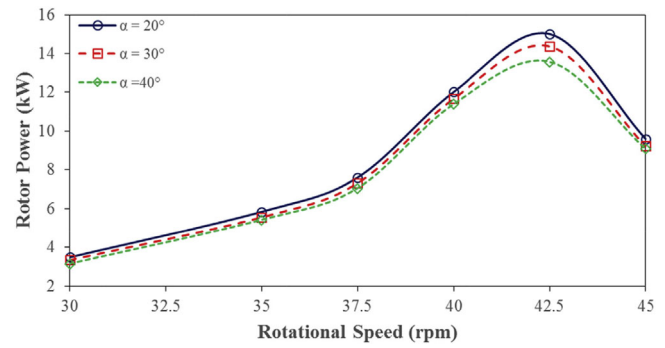

FIGURE 20 Rotor power of a horizontal Savonius-type cyclorotor, for different rotor entry angles at varying rotor speed, when submergence depth is equal to the rotors' diameter at mean sea state. [26]

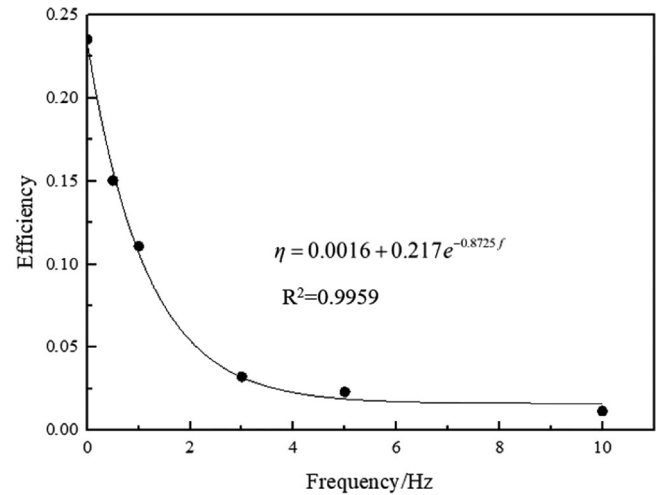

FIGURE 21 Efficiency of a vertical Darrieus-type cyclorotor, in oscillating flow, as studied in [10]

ment) and waves2Foam (a wave generation function and boundary treatment library).

A 2D numerical simulation of a vertical Darrieus-type cyclorotor with three hydrofoils was performed by Yang et al. [10] using ANSYS. This model ignores the effects of the free-surface. The model was validated by comparing the rotor's no-load rotational speed against experiments with the rotor driven in still water. A constant torque was applied to the rotation of the rotor in the numerical model to simulate power extraction. The CFD simulations considered both unidirectional and oscillatory flow and indicated that the efficiency of the energy extraction reduced with the oscillating frequency Figure 21.

## 4 | CONTROL ASPECTS OF ROTOR BASED WECs

### 4.1 | Control objectives

Wave energy converters have to be controlled to maximise energy extraction from waves. The correctly chosen control



methods can be implemented by the inclusion of an additional brake system with the possibility of declutching the generator from the cyclorotor.

- **Propellers on the hydrofoils:** A new real time control conception was proposed within the LiftWEC project [15]. A number of propellers and servomotors can be installed on the hydrofoils. This control method targets rotational speed and acceleration; however, the influence of this approach on the hydrodynamic field and circulation requires further study.

#### 4.2.2 | Periodic or sea state related control inputs

The changes in submerged depth, and operational radii, cause significant changes of the device configuration and dynamic characteristics. Traditionally they are considered to be ‘slow’ control inputs, achievable only over extended time scales (minutes), rather than real time (seconds). Typically, they can account for variations in the wave climate.

- **Device radius:** The main purpose of the radius of action cantilevers is the load transmission from the hydrofoil to the hub. By changing the length of the cantilevers, the torque on the shaft can be modulated. Although possible, it may be technically difficult to make these changes in real time, but easily achievable over the timescale of sea state variations. Thus, for the cyclorotor phase locked in sync with the wave phase, and entire wave cancellation control strategy, the operational radius has a crucial effect, since it sets the hydrofoil rotational speed, and therefore the maximum circulation and radiated wave height [24].
- **Morphing of the cyclorotor form:** Morphing of the cyclorotor is typically achieved by changing the angles between the acting radii of the hydrofoils. It is also possible to shift the rotational centre. These changes will significantly influence the inertia of the rotor.
- **The submerged depth:** Changing the operational depth can help the cyclorotor to avoid extreme weather conditions and even continue energy production at a safe water depth. If the cyclorotor can be relocated along a vertical axis, for example by moving the position of the device on a vertical monopile, it can be submerged into a region where the far-field incident velocity does not exceed the operational tolerances.
- **Circulation control:** Circulation control can dramatically increase lift coefficients in airfoils but, although the Coanda effect [61] has been recognised for decades, circulation control is still an active area of research. This method may require the installation of the additional amplifier element, or circulation control wing, in front of a cyclorotor. Controlling circulation faces the same control challenges as pitching.

### 4.3 | Overview of control approaches

The first cyclorotor-based WEC prototype, developed by Hermans et al. [2], did not have any control actuators. However, Hermans et al. proposed pitching the hydrofoils, as a control strategy, to keep the rotating wing in phase with monochromatic

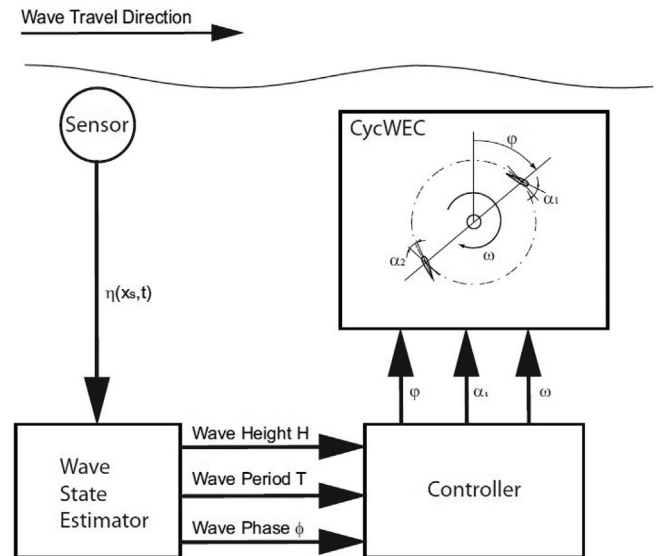

FIGURE 22 The control and estimation scheme for the CycWEC [37]

wave excitation. A method for calculation of the optimal attack angle  $\alpha(t)$  for the velocity profile of the incident wave was developed.

A wide range of scientific studies on CycWEC control methods was conducted by Atargis. The CycWEC rotor [24] contains blade pitch control actuators and a main shaft torque control system. In their published numerical studies [3, 36], Siegel et al. use the linear feedback control to synchronise the blade pitch angle, rotation rate and phase of the cyclorotor to the incoming wave; see Figure 13.

In the experimental [38] CycWEC work, the pitch angle of hydrofoils' blades were adjusted in real time, under computer control, to produce the desired level of circulation. This is achieved with the use of the two digital model aircraft servos, which were attached to the main shaft. The signal from an up-wave wave gauge was processed by a state estimator, which determines the incoming wave height  $H$ , period  $T$ , and phase  $\phi$  (Figure 22). These results were used by the controller to set up the main shaft angle  $\phi$ , and the best pitch of the blades  $\alpha$ .

The developed feedback control method of the cyclorotor has shown the efficient conversion of Airy waves and cancellation of irregular waves modeled by a Bretschneider distribution [40]

In the PhD thesis of Nik Sharmann [12], a wide range of control inputs were suggested; however, there are only general recommendations for the control design. To accord with the changing direction of the wave particle velocity, an operational strategy, called ‘synchronous control’ was proposed. This strategy orientates the rotor lever arms parallel to the free stream flow direction. However, it was noticed that adverse pitching can lead to a lower power-coefficient, compared to the pitch inactive case. To solve this problem, the use of a horizontally aligned acoustic doppler current profiler (ADCP), or an array of wave-rider buoys, to provide sufficient velocity data points from the incoming wave field, was originally proposed.

After the set of the physical and numerical tests of two hydrofoil prototypes (very similar to the CycWEC concept), it

TABLE 1 The comparison of the considered cyclorotor based WECs

WEC	Illustration	Operational elements	Control effectors	Control strategies	Performance indicators	Modeling	Prototype	Experimental tests
Rotating wing [2, 31, 32] (horizontal)		Single hydrofoil	Pitching hydrofoil angle and PTO torque control	Proposed control method: Phase control	Wave energy absorption	Analytical model: potential 2D flow, monochromatic waves	R = 0.08 m, L = 1.5 m, C = 0.1 m (2007)	2D tests in the MARIN [2]: in still water and monochromatic waves, good agreement with the theory.
Wave Rotor [4, 7, 34] (horizontal)		Two rotating cylinders	Rotational speed of the cylinders and PTO torque control	The active phase control system: a two-way radio controlled motor for cylinders	Waves energy absorption [4]; Power coefficient [7];	Analytical model: potential 2D flow, monochromatic waves	$r_{cyl} = 0.0175$ m, L = 0.382 m, R = 0.08 m (2000)	2D tests in a flume [7]: absorption $\approx 5\%$ of incident wave power, demonstrated the synchronous rotation in a regular wave
Wh-WEC [12] (horizontal)		Four hydrofoils	PTO torque control	Robust control: orientate the rotor lever arms parallel to the flow direction	Power coefficient and LCOE	Analytical model: potential flow, multi-chromatic waves; Numerical Model: ANSYS and Open-FOAM	R = 0.3 m, NACA0015: C = 0.3 m (2014)	2D tests in HSVA of 1:20 prototype in monochromatic waves: validation of the numerical models
CycWEC [3, 13, 24, 28, 35–40, 50–55]		Two hydrofoils	Pitching hydrofoil angle and PTO torque control	The feedback control method: entire wave cancellation	Power coefficient, Energy production, LCOE	Analytical model of wave cancellation in potential flow, Numerical 2D potential flow with irregular waves model complemented by 3D radiation model	R = 1 m, L = 4.5 m, NACA0015: C = 0.75 m (2012)	2D tests in US Air Force Academy of 1:300 prototype [37] and 3D tests in Wave Basin Texas A&M OTRC 1:10 prototype [13]: validation of the numerical models and device concept, TRL 3 $\rightarrow$ 4
Savonius rotor [26, 42]		Three blades	PTO torque control	Control option was not realised	Power generation and wave energy absorption	The numerical 2D [42] and 3D [26] simulation in ANSYS for monochromatic waves	R = 0.9 m, L = 3 m, $\text{curv.} = 20^\circ$	(Continues)

TABLE 1 (Continued)

WEC	Illustration	Operational elements	Control effectors	Control strategies	Performance indicators	Modeling	Prototype	Experimental tests
Savonius rotor [5, 41] horizontal		Five blades	PTO torque control	Control option was not realised	Rotational speed		$R = 0.066$ m, $L = 0.3$ m, curv = $70^\circ$ (2013)	2D tests were conducted to find the optimal curvature which provides the max rotational speed in monochromatic waves
Savonius rotor [9] horizontal and vertical		Five blades	PTO torque control	Control option was not realised	Power coefficient		curv = $72^\circ$ , $R = 0.055$ m, $r_{shaft} = 0.011$ m (2014)	the wave flume with monochromatic waves, the efficiency 6–8% with a manual and 13.9% with an electronic loading systems
A single-bucket drag-type cross-flow turbine [43]		Single-bucket with counterweight	PTO torque control	Proposed: the synchronization of turbine rotation with the incident wave	Power coefficient	2D model in Open-FOAM: potential flow, monochromatic waves, efficiency $\approx 3.57\%$	Turbine $R = 0.1$ m, the chord length of the bucket is 0.10 m	
C-Energy demonstrator [44]		Darrieus-Wells Rotor [6, 11] (3 blades of each type)	PTO torque control	Control option was not realised	Power coefficient		The 1:2 scale prototype 30kWp C-Energy demo: $R = 2.5$ m and $H = 5$ m	The set of tests in various european universities led to creation of the 30kWp C-Energy demonstrator [44]
Vertical-axis rotors studied by Yang et al. [10, 25 45–48]		Lift-type and/or drag-type blades	PTO torque control	Robust control was proposed	Rotational speed or Power coefficient	2D cross-section of the rotor with three NACA0021 was tested in ANSYS.	$R = 0.25$ m, distance between two levels $L = 0.1524$ m (2018)	Tests of the conceptions in a flume. The results confirmed the rotor's unidirectional. Rotational speed of the lift type foils is much faster.

was shown that, for polychromatic real waves, such a two foil rotor will have highly fluctuating torque, since the condition of orthogonality between rotational and wave particle velocities cannot be held without allowing discontinuous rotor position setpoint values. As a result, Scharmann [12] selected a four-foil fixed-pitch concept. It combines a straightforward robust control concept with an acceptable  $C_p$ , while still being flexible enough to potentially operate in real sea states.

In the study of Folley and Whittaker [16], the range of methods for controlling the rotation and circulation for operation in irregular waves is discussed. The authors consider pitch angle control to generate the optimum lift force that is required, while the torque is controlled, using the electrical machine as a motor, to achieve optimum phase match with the incident wave. The more innovative ‘inertial phase control’, which allows the angular velocity to be controlled through the conservation of angular momentum and operational radius control, are also discussed.

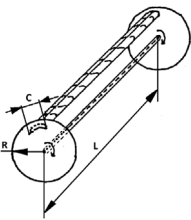
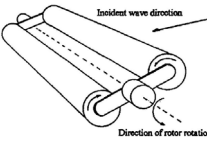
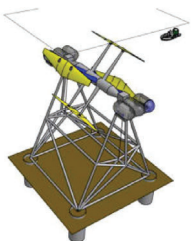
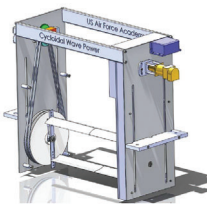
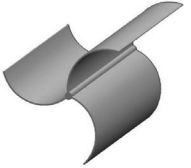
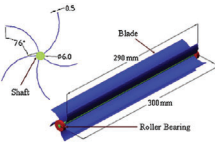
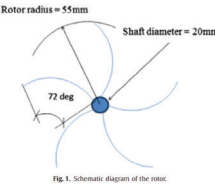
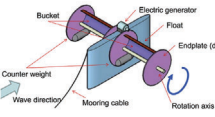
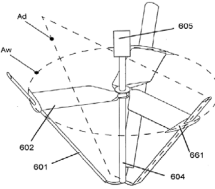
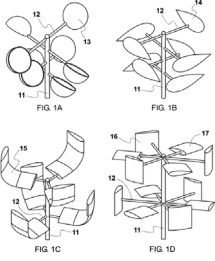
Different control actuators are used for ‘Wave Rotor’ studied by J. R. Chaplin [4]. This device comprises two parallel contra-rotating cylinders in orbital motion, and overall torque can be controlled by adjusting their rotational speed. The same control strategy, of keeping the rotor in phase with incoming waves, was proposed. However, some experiments have shown the difficulties with such a control method, due to the high inertia of the cylinders.

For the Savonius and Darrieus-Wells type rotors, only PTO torque and submergence control strategies are possible. However, researchers who studied the application of these devices to wave energy conversion were more concerned with searching for the optimal design of the device, rather than an effective control algorithm.

#### 4.4 | Outstanding challenges

Only a limited number of control strategies for rotor-based WECs have been developed and tested, in comparison with more traditional WEC devices. This can be explained by the difficulty of controlling the cyclorotor in an irregular wave environment, its more complex control systems, which often includes more than one control input and changes to the device configuration. Another challenge is the need for a reliable forecast of the wave and lift force inputs.

The majority of control strategies were tested in idealistic potential flow and monochromatic waves environments. These models have not considered viscous losses and waves radiation. For this reason, a number of researchers have changed their control strategies and device designs, following tank tests.

Generally, the range of current cyclorotor control design problems can be summarised as follows:

- Choice of the correct control effectors.
- Development of the optimal control strategy.
- Reliable incoming wave and lift force forecasts.
- Maintenance of unidirectional rotation and stabilisation of fluctuations in main shaft torque and rotational velocity.

## 5 | PERSPECTIVES

### 5.1 | Advantages/disadvantages compared to other WEC types

Despite their relative popularity among the range of WEC prototypes available, cyclorotor WECs have a number of potential advantages compared to other WEC types. In particular, most WECs (with the notable exception of overtopping devices) use reciprocating motion for energy conversion, which is a natural consequence of alternating free surface variations in heave, surge and pitch. This requires a rectification stage, either at the mechanical [62], hydraulic [63], aerodynamic [64], or electrical [65] stage. In contrast, cyclorotors naturally have unidirectional rotational motion, which is also very convenient in having no physical end-stops, typically characteristic of WECs which utilise translational motion. Other advantages of cyclorotor-based WECs is improved storm survivability, due to fully submerged operation, and better power to weight ratio for the hydrofoil devices, due to larger operational velocities [24].

However, cyclorotors are not without their comparative disadvantages. At particular points in the rotational cycle, each foil generates more drag than lift, limiting the useful converted power. Thus, the cyclorotor must be actively controlled to ensure the optimal phase and instantaneous rotational velocity [12, 24]. The implementation of suitable control requires a sensor system which can provide a reliable forecast of the incoming wave properties. In addition, the phase control problem (which attempts to get the device rotational velocity into ‘phase’ with the lift excitation force) is known to be considerably more difficult for cyclorotors, particular in irregular waves [12]. The numerical modelling of the rotor, with the use of commercial software, also provides some challenges because none of the well-established marine (free surface) panel codes currently support lift-generating devices [14].

### 5.2 | Current state of development

At this moment there are no commercial rotor-based WEC offerings ready for market, nor have any full-scale prototypes been built. Among the existing horizontal cyclorotor concepts, only CycWEC [24] and WH-WEC [12] have reached technology readiness level 4, within the framework of the Marine and Hydrokinetic Technology Readiness Advancement Initiative of the U. S. Department of Energy [66].

The most advanced vertical rotor prototype at the moment is 1:2 scale Darrieus-Wells Rotor, developed within the OceanMill project [44]. However, this device is targeted at tidal, as well as wave, energy. The others devices exists only as small scale prototypes, which have been tested in laboratory flumes and tanks, or just as physical-mathematical models, tested in engineering software. A complete summary overview of information on the devices covered in this review, and their current state of the development, can be found in Table 1.

### 5.3 | Main challenges in commercial development of cyclorotor technology

As this review has shown, there is little convergence on an optimal cyclorotor concept, which is symptomatic of the WEC industry in general. The design topology of the studied concepts is diverse, as well as wave energy extraction method. Not only are cyclorotors, as a WEC concept, competing against other renewable energy forms, but also against other more established WEC concepts, such as point absorbers and oscillating wave surge converters.

Mathematical modeling of wave rotor fluid/device interaction is a challenging problem, since it can not be presented in the simplified linear form such as Cummins' equation [67], which is typical of more traditional WEC concepts. The significant, and undeniable, non-linearity of the model causes significant computational, as well as analytical, problems. As a result, most wave rotor simulation is conducted in 2D, using potential flow.

While the WEC control problem for traditional WEC systems is reasonably well understood [21], the optimal control approach for cyclorotor systems is not yet clear. Cyclorotors have a number of potential control effectors (foil angle/shape, rotational torque, depth etc.) which give considerable opportunities to address the control problem. However, maintaining a number of possible control effectors may not be economically advantageous. While cyclorotors have high potential in, for example, energy to mass ratio, and shown to be able to operate well in regular waves, the difficulty in establishing efficient operation in irregular waves has yet to be effectively accomplished, which represents the normal realistic case. With respect to operation in irregular waves, with consequent variations in device velocity and excitation torque, control technology may have an important part to play in maximising absorbed energy for wave rotor devices.

## 6 | CONCLUSIONS

Due to limited success with the development of traditional WEC devices which use buoyancy or diffraction wave forces, researchers have begun to search for new approaches to wave energy conversion, such as obtaining energy from elliptical motion of water wave particles using rotors. Rotors have some appealing characteristics, particularly unidirectional motion and sub-surface operation, which eases the PTO/constraint issues and can provide some immunity to extreme loading. However, the accumulated knowledge on rotors, in terms of validated mathematical models and experimental testing, is limited. As with many wave energy prototype systems, there is significant variety within the class of rotors, suggesting that there is still some distance to go before convergence on an optimal geometry is reached. Some problems, such as torque and velocity fluctuation, have been identified, particularly in the optimal synchronisation of the rotational motion with the wave life/excitation force for panchromatic wave inputs. Control technology is one possible avenue to explore, in making

wave rotors effective wave energy conversion systems, under realistic wave conditions.

### ACKNOWLEDGEMENTS

This project has received funding from the European Union's Horizon 2020 research and innovation programme under grant agreement No. 851885. The authors are grateful for the contribution to this review by Drs. Matt Folley and Paul Lamont-Kane and Prof. Trevor Whittaker, all of Queen's University Belfast. Thanks are also due to other members of the LiftWEC consortium, for useful discussions.

### ORCID

Andrei Ermakov  <https://orcid.org/0000-0002-8426-1798>

John V. Ringwood  <https://orcid.org/0000-0003-0395-7943>

### REFERENCES

- McCormick, M.: Ocean wave energy concepts. In: Proceedings of OCEANS '79, San Diego (1979)
- Hermans, A.J., Sabben, E.V., Pinkster, J.A.: A device to extract energy from water waves. *Appl. Ocean Res.* 12(4), 175–179 (1990)
- Siegel, S.G., Jeans, T., McLaughlin, T.E.: Intermediate ocean wave termination using a cycloidal WEC. In: Proceedings of 29th International Conference on Ocean, Offshore and Arctic Engineering, Shanghai (2010)
- Chaplin, J.R., Retzler, C.H.: Predictions of the hydrodynamic performance of the wave rotor wave energy device. *Appl. Ocean Res.* 17(6), 343–347 (1995)
- Ahmed, M.R., Faizal, M., Lee, Y.H.: Optimization of blade curvature and interrotor spacing of Savonius rotors for maximum wave energy extraction. *Ocean Eng.* 65, 32–38 (2013)
- Scheijgrond, P.: A device for the utilisation of wave energy and a method. International Patent WO/2010/011133 (28/01/2010), accessed (22/04/2021)
- Retzler, C.H.: The wave rotor. In: Proceedings of the Second European Wave Power Conference, Lisbon (1995)
- Siegel, S., Jeans, T., McLaughlin, T.: Deep ocean wave cancellation using a cycloidal turbine. In: Proceedings of the 62nd Annual Meeting of the American Physical Society, Division of Fluid Dynamics, Minneapolis (2009)
- Bikas, G.S., Ramesh, H., Vijaykumar, H.: Study on performance of Savonius rotor type wave energy converter used in conjunction conventional rubble mound breakwater. *Ocean Eng.* 89, 62–68 (2014)
- Lei, J. et al.: Numerical simulation of wave energy converter with hydrofoil blades under various wave conditions. In: Proceedings of ASME 2019 13th International Conference on Energy Sustainability, Washington (2019)
- Rossen, E.A., Scheijgrond, P.C., Mikkelsen, R.: Development and model tests of a combined well's darrieus wave rotor. In: Proceedings of the 4th European Wave Energy Conference, Aalborg (2000)
- Scharmann, N.: Ocean energy conversion systems: The wave hydro-mechanical rotary energy converter. Dissertation, Institute for Fluid Dynamics and Ship Theory, TUHH, Hamburg (2014)
- Siegel, S.G.: Cycloidal wave energy converter, Final scientific report submitted to DOE EERE—Wind and Water Power Program. Atargis Energy Corporation, Pueblo (2013)
- Atargis Energy Corporation, <https://atargis.com/>, accessed (22/04/2021)
- LiftWEC Consortium, <https://liftwec.com/>, accessed (22/04/2021)
- Folley, M., Whittaker, T.: Lift-based wave energy converters—An analysis of their potential. Proceedings of the 13th European Wave and Tidal Energy Conference, Napoli (2019)
- Folley, M., Gnanaruban, V.: Computational fluid dynamic modelling of a liftbased wave energy converter. Proceedings of the 28th International Symposium on Transport Phenomena, Peradeniya (2017)

18. Retzler, C.H.: Wave power project: A spinning cylinder in waves. SERC Grant Number GR/D/8425.2 Report, Edinburgh University (1987)
19. Wehausen, J.V., Laitone, E.V.: Surface Waves, Handbook of Physics, vol. 9, Springer, Heidelberg (1960)
20. Penalba, M., Ringwood, J.: A review of wave-to-wire models for wave energy converters. *Energies* 9(7), 506 (2016)
21. Ringwood, J.V., Bacelli, G., Fusco, F.: Energy-maximizing control of wave energy converters: The development of control system technology to optimize their operation. *IEEE Control Syst. Mag.* 34(5), 30–55 (2014)
22. Papillon, L., et al.: Parametric modelling of a reconfigurable wave energy device. *Ocean Eng.* 186, 106105 (2019)
23. Retzler, C.H.: Experimental results for the wave rotor wave energy device. In: Proceedings of the Tenth International Offshore and Polar Engineering Conference, Seattle (2000)
24. Siegel, S.G.: Numerical benchmarking study of a cycloidal wave energy converter. *Renewable Energy* 134, 390–405 (2019)
25. Yang, Y. Wave energy converter. US Patent 2018/0202412 A1 (19/07/2018), accessed (22/04/2021)
26. Ahmed, M.R., Prasad, D.D., Lee, Y.H.: Studies on the performance of Savonius rotors in a numerical wave tank. *Ocean Eng.* 158, 29–37 (2018)
27. Caskey, C.J.: Analysis of a cycloidal wave energy converter using unsteady Reynolds averaged Navier-Stokes simulation. Dissertation, University of New Brunswick (2014)
28. Fagley, C., Siegel, S.G., Seidel, J.: Numerical simulations of a cycloidal wave energy converter. In: Proceedings of the 1st Asian Wave and Tidal Conference Series, Jeju Island (2012)
29. Lamont-Kane, P., Folley, M., Ermakov, A.: LiftWEC Project Deliverable D2.3: Review of current lift-based WEC concepts and specification of preliminary configurations. <https://liftwec.com/deliverables/>, accessed (22/04/2021)
30. Sabben, E.: Velocity field of a rotating foil in still water and waves. Dissertation, TU Delft, Delft (1987)
31. Pinkster, J.A., Hermans, A.J.: A rotating wing for the generation of energy from waves. In: Proceedings of the 22nd International Workshop on Water Waves and Floating Bodies, Plitvice (2007)
32. Marburg, C.: Wave energy conversion by a rotating hydrofoil experimental results with a rotating hydrofoil analysis of experiments with a rotating hydrofoil investigation on a rotating foil for wave energy conversion. Dissertation, TU Delft, Delft (1994)
33. Jacobs, E.N., Ward, K.E., M., P.R.: The characteristics of 78 related airfoil sections from tests in the variable-density wind tunnel, NACA Report No 460 (1935)
34. Retzler, C.H.: Wave energy converter. Patent GB2262572 (23/06/1993), accessed (22/04/2021)
35. Siegel, S.G.: Cyclical wave energy converter. US Patent US20100150716A1 (17/06/2010), accessed (22/04/2021)
36. Siegel, S.G., Jeans, T., McLaughlin, T.E.: Deep ocean wave energy conversion using a cycloidal turbine. *Appl. Ocean Res.* 33(2), 110–119 (2011)
37. Siegel, S.G., Fagley, C., Nowlin, S.: Experimental wave termination in a 2D wave tunnel using a cycloidal wave energy converter. *Appl. Ocean Res.* 38, 92–99 (2012)
38. Siegel, S.G. et al.: Experimental investigation of irregular wave cancellation using a cycloidal wave energy converter. In: Proceedings of the 31st International Conference on Ocean, Offshore and Arctic Engineering, Rio de Janeiro (2012)
39. Siegel, S.G. et al.: Experimental wave generation and cancellation with a cycloidal wave energy converter. In: Proceedings of the 30th International Conference on Offshore Mechanics and Arctic Engineering, Rotterdam (2011)
40. Fagley, C., Siegel, S.G., Seidel, J.: Wave cancellation experiments using a 1:10 scale cycloidal wave energy converter. In: Proceedings of 1st Asian Wave and Tidal Conference Series, Jeju Island (2012)
41. Ahmed, M.R., Faizal, M., Lee, Y.H.: On utilizing the orbital motion in water waves to drive a Savonius rotor. *Renewable Energy* 35(1), 164–169 (2010)
42. Ahmed, M.R., Lee, Y.H.: Performance evaluation of a direct drive wave energy converter using CFD. *Renewable Energy* 49, 237–241 (2013)
43. Akimoto, H., Tanaka, K., Kim, Y.Y.: Drag-type cross-flow water turbine for capturing energy from the orbital fluid motion in ocean wave. *Renewable Energy* 76, 196–203 (2015)
44. C-Energy. Oceanmill. <https://sites.google.com/site/oceanmilltest/services>, accessed (22/04/2021)
45. Yang, Y., Diaz, I., Morales, M.: A vertical-axis unidirectional rotor for wave energy conversion. *Ocean Eng.* 160, 224–230 (2018)
46. Yang, Y. et al.: Responsiveness comparison between a lift-type and drag-type rotor in waves. In: Proceedings of the 3rd International Conference on Sustainable and Renewable Energy Engineering, Salamanca (2018)
47. Yang, Y. et al.: A parametric study of wave interaction with a rotor having hydrofoil blades. In: Proceedings of AMSE 2018, Florida (2018)
48. Yang, Y., et al.: Experimental study of a lift-type wave energy converter rotor in a freewheeling mode. *J. Energy Res. Technol.* 142(3), 031201 (2020)
49. Katz, J., Plotkin, A.: *Low-speed Aerodynamics*, 2nd ed., pp. 390–405. Cambridge University Press, Cambridge (1960)
50. Fagley, C., Siegel, S.G., Seidel, J.: Computational investigation of irregular wave cancellation using a cycloidal wave energy converter. In: Proceedings of the 31st International Conference on Ocean, Offshore and Arctic Engineering, Rio de Janeiro (2012)
51. Siegel, S.G. et al.: Irregular deep ocean wave energy conversion using a cycloidal wave energy converter. In: Proceedings of the 9th European Wave and Tidal Energy Conference, Southampton (2011)
52. Siegel, S.G.: Wave radiation of a cycloidal wave energy converter. *Appl. Ocean Res.* 49, 9–19 (2015)
53. Fagley, C. et al.: 3D wave radiation efficiency of a double cycloidal wave energy converter. Proceedings of the 32nd International Conference on Ocean, Offshore and Arctic Engineering, Nantes (2013)
54. Fagley, C. et al.: 3D efficiency analysis of cycloidal wave energy converters in oblique wave fields. Proceedings of the 32nd International Conference on Ocean, Offshore and Arctic Engineering, Nantes (2013)
55. Siegel, S.G.: Wave climate scatter performance of a cycloidal wave energy converter. *Appl. Ocean Res.* 48, 331–343 (2014)
56. ANSYS Inc.: ‘ANSYS Fluent Theory Guide’, (2013): accessed (22/04/2021)
57. ANSYS Inc.: ANSYS CFX-Solver Modelling Guide (2016)
58. OpenFOAM User Guide: The Open Source CFD Toolbox (2020)
59. Leu, M.C., Ghazanfari, A., Kolan, K.: NX10 for Engineering Design, Department of Mechanical and Aerospace Engineering, Missouri University of Science & Technology (2011), accessed (22/04/2021)
60. Ringwood, J.V.: Wave energy control: Status and perspectives 2020. Proceedings of IFAC World Congress, Berlin (2020)
61. Tritton, D.J.: *Physical Fluid Dynamics*. Springer, Dordrecht (1977)
62. Chen, C.A., et al.: Circuit modelling of the mechanical motion-rectifier for electrical simulation of ocean wave power take-off. *IEEE Trans. Ind. Electron.* 68(4), 3262–3272 (2020)
63. Costello, R., Ringwood, J.V., Weber, J.: Comparison of two alternative hydraulic PTO concepts for wave energy conversion. In: Proceedings of the 9th European Wave and Tidal Energy Conference (EWTEC), Southampton (2011)
64. Falcão, A.F., Henriques, J.C., Gato, L.M.: Self-rectifying air turbines for wave energy conversion: A comparative analysis. *Renewable Sustainable Energy Rev.* 91, 1231–1241 (2018)
65. Ekström, R., Ekerlgård, B., Leijon, M.: Electrical damping of linear generators for wave energy converters—A review. *Renewable Sustainable Energy Rev.* 42, 116–128 (2015)
66. U. S. Department of Energy, Golden field office, Marine and hydrokinetic technology readiness advancement initiative, Funding opportunity announcement DE-FOA-0000293, (2010), accessed (22/04/2021)
67. Cummins, W.: The impulse response function and ship motions. *Schiffstechnik* 9, 101–109 (1962)

**How to cite this article:** Ermakov, A., Ringwood, J.V. Rotors for wave energy conversion—Practice and possibilities. *IET Renew. Power Gener.* 15:3091–3108 (2021). <https://doi.org/10.1049/rpg2.12192>