

WORLD METEOROLOGICAL ORGANIZATION

**INTERGOVERNMENTAL OCEANOGRAPHIC
COMMISSION (Of UNESCO)**

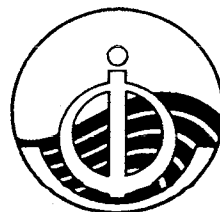

MARINE METEOROLOGY AND RELATED OCEANOGRAPHIC ACTIVITIES

REPORT NO. 25

SHIPS OBSERVING MARINE CLIMATE

**A CATALOGUE OF THE VOLUNTARY OBSERVING SHIPS
PARTICIPATING IN THE VSOP-NA**

WMO/TD-No. 456

1991

NOTE

The designations employed and the presentation of material in this publication do not imply the expression of any opinion whatsoever on the part of the Secretariats of the World Meteorological Organization and the Intergovernmental Oceanographic Commission concerning the legal status of any country, territory, city or area, or of its authorities, or concerning the delimitation of its frontiers or boundaries.

Editorial note: This publication is an offset reproduction of a typescript submitted by the authors and has been produced without additional revision by the WMO and IOC Secretariats.

SHIPS OBSERVING MARINE CLIMATE

**A CATALOGUE OF THE VOLUNTARY OBSERVING SHIPS
PARTICIPATING IN THE VSOP-NA**

Elizabeth.C.Kent and Peter.K.Taylor

James Rennell Centre for Ocean Circulation,

Chilworth Research Park,

Southampton,

UK

P R E F A C E

Meteorological observations made onboard merchant vessels of the WMO voluntary observing ships (VOS) scheme, when transmitted to shore in real-time, are a substantial component of the Global Observing System of the World Weather Watch and are essential to the provision of marine meteorological services, as well as to meteorological analyses and forecasts generally. These observations are also recorded in ships' meteorological logbooks, for later exchange, archival and processing through the WMO Marine Climatological Summaries Scheme, and as such they constitute an equally essential source of data for determining the climatology of the marine atmosphere and ocean surface, and for computing a variety of air-sea fluxes. At the same time, however, it has long been recognized that these observations are subject to errors, both systematic and random. Many of these errors are the result of inadequate or inappropriate instrument siting onboard ship, or through the use of instrumentation or observing techniques which are less than optimal.

The VOS Special Observing Project North Atlantic (VSOP-NA) was therefore initiated, jointly by the WMO Commission for Marine Meteorology (CMM) and the Committee on Climate Changes and the Ocean (CCCC) of IOC/SCOR, on behalf of the WCRP, to try to establish the effects on the quality of VOS data of different ship instrumentation and observing practices.

Six national observing fleets participated - those of Canada, France, Germany, Netherlands, United Kingdom and USA - and ultimately 45 ships supplied data for the project. New logbooks were designed to enable the acquisition of supplementary information to define the detailed instrumentation and practices in use by each ship, so that the effects of these differing methods of data gathering could be quantified. These logbooks were collected by participating Port Meteorological Officers at the end of each voyage, and submitted to the project digitizing centre operated by the Seewetteramt of the German Weather Service in Hamburg. From there, the data were transferred to the United Kingdom Meteorological Office in Bracknell for archival and analysis, jointly by the Meteorological Office and the James Rennell Centre in Southampton. Eventually a total of more than 33,000 observations were collected during the project observation period from May 1988 to September 1990 and these, together with the information on instrument siting and exposure and the meteorological analysis fields from the numerical model of the United Kingdom Meteorological Office, provided the basis for the data analysis.

This particular document, prepared by Ms Elizabeth Kent and Dr. Peter Taylor of the James Rennell Centre, Southampton, United Kingdom contains a catalogue of the VSOP-NA ships, describing in detail the ships' characteristics, routes and meteorological instruments fitted. A companion report to this (No. 26 in the same series) gives a summary of the data acquisition, data processing and analysis phases of the project and describes the results of the analysis.

There is no doubt that the results of this project are of considerable importance to climate analysis and modelling, in particular in their implications for the computation of air-sea fluxes of heat, momentum and water vapour. They are also likely to have a significant and beneficial impact eventually on the operation of the whole of the VOS, with consequent benefits not just for research but also for operational meteorology.

The considerable appreciation of the sponsoring organizations for the project is extended to the authors of these two reports, Ms E. Kent and Dr. P. Taylor of the James Rennell Centre and Mr. B. Bruscott and Mr. J. Hopkins of the United Kingdom Meteorological Office for their substantial and high quality analysis work. Thanks are also due to the Seewetteramt, Hamburg, for undertaking the major task of digitizing the data; to the members of the project Management Committee for their excellent supervision of the project; to the Port Meteorological Officers of the countries concerned for recruiting and servicing the project ships; and last but by no means least, to the officers and crew of the ships themselves, for their co-operation and support for the project, without which nothing would have been possible. It is hoped that they will eventually see the direct fruit of their efforts in the form of improved meteorological forecast and warning services for mariners.



(J. Rasmussen)

for the Secretary-General of WMO

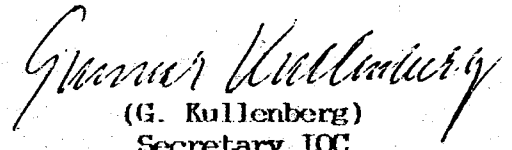

(G. Kullenberg)
Secretary IOC

CONTENTS

Page

PART 1 SUMMARY OF THE SHIP CHARACTERISTICS	1
1. INTRODUCTION	1
2. THE VSOP-NA PROJECT	1
2.1 Introduction	1
2.2 Ship Selection	2
2.3 Ship Documentation	2
2.4 Extra Observations	3
2.5 Data Processing and Analysis	3
3. SUMMARY OF THE VSOP-NA SHIP CHARACTERISTICS	4
3.1 Names and Call Signs of the VSOP-NA ships	4
3.2 Period of Participation in the VSOP-NA	4
3.3 Reporting Efficiency	7
3.4 Ship Routes	8
3.5 Ship Type	9
3.6 Ship Size	12
3.7 Ship Speed	12
3.8 Variation in Sensor Heights	12
4. INSTRUMENTATION SUMMARY	14
4.1 Winds	14
4.2 Air Temperature and Humidity	19
4.3 SST	21
4.4 Pressure	24
4.5 Communications	28
5. SUMMARY OF PART 1	28
6. ACKNOWLEDGEMENTS	29
7. REFERENCES	29

CONTENTS**Page****PART 2 THE SHIP CATALOGUE****31****1 Introduction****31**

Ships recruited by Canada

VSBG8 Irving Forest

32

Ships recruited by France

DIDA Ariana

34

FNCZ C R Libreville

36

FNEF Atlantic Cartier

38

FNFD Edouard L D

40

FNGM Le Carabie

42

FNGS La Fayette

44

FNOY Jean Charcot

46

Ships recruited by Germany

DDLN Independent Endeavor

48

DDUC Euro Texas

50

DHNE Nurnberg Atlantic

52

DHRG Alemania Express

54

DIMC America Express

56

DNBR Independent Concept

58

DNJR Independent Pursuit

60

Ships recruited by the Netherlands

PCEL AEL America

62

PELT Gulf Speed

64

PELU Gulf Spirit

66

PGDG Nedlloyd Kingston

68

PGDS Nedlloyd Kyoto

70

PGDW Nedlloyd Zeelandia

72

PGEG Nedlloyd Neerlandia

74

Ships recruited by the UK

LIMA Cumulus

76

C6DS Atlantic Link

78

GBSA Author

80

GBVV Geestbay

82

GBVW Geestport

84

GJMR Geestcape

86

GJMS Geesthaven

88

GXES CGM Provence

90

GZMM Atlantic Conveyor

92

VRAZ Nickerie

94

VSBV3 CanMar Ambassador

96

Ships recruited by the USA

IBPA Americana

98

KLRZ Sealand Atlantic

100

KRGJ Julius Hammer

102

KRJL Margarete Lykes

104

KRJP Sheldon Lykes

106

KRPB Sealand Commitment

108

WMLG Delaware Bay

110

WPFZ Adabelle Lykes

112

WPHZ Charlotte Lykes

114

WPVF Galveston Bay

116

WPWH Nedlloyd Hudson

118

WSDG Lyra

120

Appendix 1 Hull Sensor Specifications**123**

SHIPS OBSERVING MARINE CLIMATE
A CATALOGUE OF THE VOLUNTARY OBSERVING SHIPS
PARTICIPATING IN THE VSOP-NA¹

E.C.Kent and P.K.Taylor
James Rennell Centre for Ocean Circulation, Chilworth Research Park, Southampton, UK

PART 1 SUMMARY OF THE SHIP CHARACTERISTICS

1. INTRODUCTION

Our present knowledge of the marine climate, as represented by data sets such as COADS (Woodruff et al., 1987), is based on meteorological observations from the Voluntary Observing Ships (VOS). Because the VOS are merchant ships, rather than specially designed meteorological platforms, errors and biases exist in the data. However there is little information readily available to the climatologist either on the nature of the VOS fleet or on the observing practises which are used. This report, describing the forty-six ships which participated in the Voluntary Observing Ships' Special Observing Project - North Atlantic (VSOP-NA), therefore serves two purposes:

- (i) it provides a reference document to aid analysis of the VSOP-NA data set,
- (ii) it gives a detailed description of a subset of the VOS which will be of value in the interpretation of marine climate data sets.

This report is in two parts, Part 1 is an overall summary of the ship characteristics, Part 2 is a ship by ship description. The next section will briefly describe the VSOP-NA project, followed by a summary of the characteristics of the VSOP-NA ships (Section 3). Since these ships were specially selected (Section 2.2), the degree to which they are representative of the whole VOS fleet will be carefully considered. The meteorological instrumentation used by the VOS varies depending on which meteorological agency recruited the ships. That used on the chosen VSOP-NA ships is typical of VOS recruited by the countries bordering the North Atlantic, and will be described in Section 4. Section 5 is a summary of Part 1 of the report.

Part 2 presents the VSOP-NA ship catalogue. This includes, for each ship, diagrams of the layout (indicating in particular the exposure of the sensors), a summary of the geographical positions at which observations were obtained, and details of the instrumentation used.

2. THE VSOP-NA PROJECT

2.1 Introduction

The VSOP-NA was a pilot study with the primary objective of assembling a detailed subset of marine meteorological data. The aim was to determine whether systematic biases in the measurements could be quantified through the acquisition of additional ship information which is not routinely collected. The stages of the VSOP-NA project consisted of the initial ship selection and documentation by the Port Meteorological Officers (PMO's), an observational phase during which

¹ Prepared for the VSOP-NA management Committee Meeting, June 24 - 27, Reading U.K.

extra observation codes were reported by the ship's officers, and the data processing and analysis conducted collaboratively by the Deutscher Witterdienst, Seewetteramt, the UK Meteorological Office, and the James Rennell Centre. The data collection phase of VSOP-NA was in operation from May 1988 to September 1990. Full details of the analysis procedures and the results of the comparisons are reported by Kent et al. (1991).

2.2 Ship Selection

In planning the VSOP-NA it was determined that ships should be recruited using three main criteria (WMO, 1987). First, the ship had to be operating almost exclusively in the North Atlantic. This meant that if the routing of a ship changed away from this region it had to be dropped from the project. Second, the normal reporting record of the ship was to be taken into account and only ships with good reporting records were to be considered for recruitment. The final consideration was to be the quality of instrumentation on the ship, ideally the ships were required to have:

- (a) accurate and well-exposed wet and dry bulb mercury in glass or electrical resistance thermometers;
- (b) sea surface temperature measuring instruments for one of the preferred methods (buckets, precision thermometer placed close to the engine room intake point, or trailing thermometers);
- (c) permanently-mounted, well exposed anemometers;
- (d) precision marine barometers.

Thus, as originally specified, these criteria would have prevented the VSOP-NA ships from forming a representative subset of the VOS. However, in practise it was found that, in order to attempt to recruit the target of 50 ships into the VSOP-NA, the ships were mainly selected on the basis of good reporting record, a likelihood of operating mainly in the North Atlantic, and the readiness of the ships' owners and crew to cooperate in the project. Even then only a total of 45 ships were recruited and subsequently provided reports. Thus the VSOP-NA ships are likely to be typical of the regularly reporting VOS in the North Atlantic, and probably also of a significant fraction of the the VOS fleet. This question will be considered in more detail in the following sections.

2.3 Ship Documentation

Following the selection of a ship, the Port Meteorological Officers were requested to obtain details of the types of instrumentation carried, the siting of fixed instruments (or the position in which hand held instruments were used), and, if possible, to obtain scale drawings and photographs showing the general layout of the ship and the exposure of the instruments. It is the information from this documentation which is presented in this report, in summary in Sections 3 and 4 and in detail in Part 2. The original documentation will be submitted to the UKMO for permanent archiving.

2.4 Extra Observations

The ships' officers were requested to report extra information with each observation (Table 1). The extra codes were entered onto a VSOP-NA logsheet which was collected by the PMO's and returned to the Deutscher Wietterdienst, Seewetteramt in Hamburg.

Table 1. The extra information which ship's officers were requested to report with each observation.

	Code	Information
1	SS	Instantaneous ship's speed at time of observation
2	DDD	Ship's heading in degrees true
3	LL	Height in metres of deck cargo above main deck
4	hhh	Departure of reference level from actual sea level
5	M	Method of sea surface temperature measurement
6	n	Location of air temperature measurement
7	fff	Relative wind speed (knots or m/s)
8	ddd	Relative wind direction in degrees off the bow

2.5 Data Processing and Analysis

At the Deutscher Wietterdienst, Seewetteramt the data were transcribed onto magnetic tape and forwarded to the UK Meteorological Office where the final data set was constructed by merging the observations with the corresponding variables output from the analysis stage of the Meteorological Office atmospheric forecast model. The final data set was prepared in March 1991, observations which arrived at the Meteorological Office after that time had to be excluded from the analysis. Nevertheless, data recorded up to April 1991 were transcribed and became part of the special archive of VSOP-NA data. Also excluded from the data set were observations in areas near the coasts of North America and Spain where the model value were considered to be strongly affected by the nearby land. The area for which data were accepted and the geographical distribution of observations is shown in figure 1.

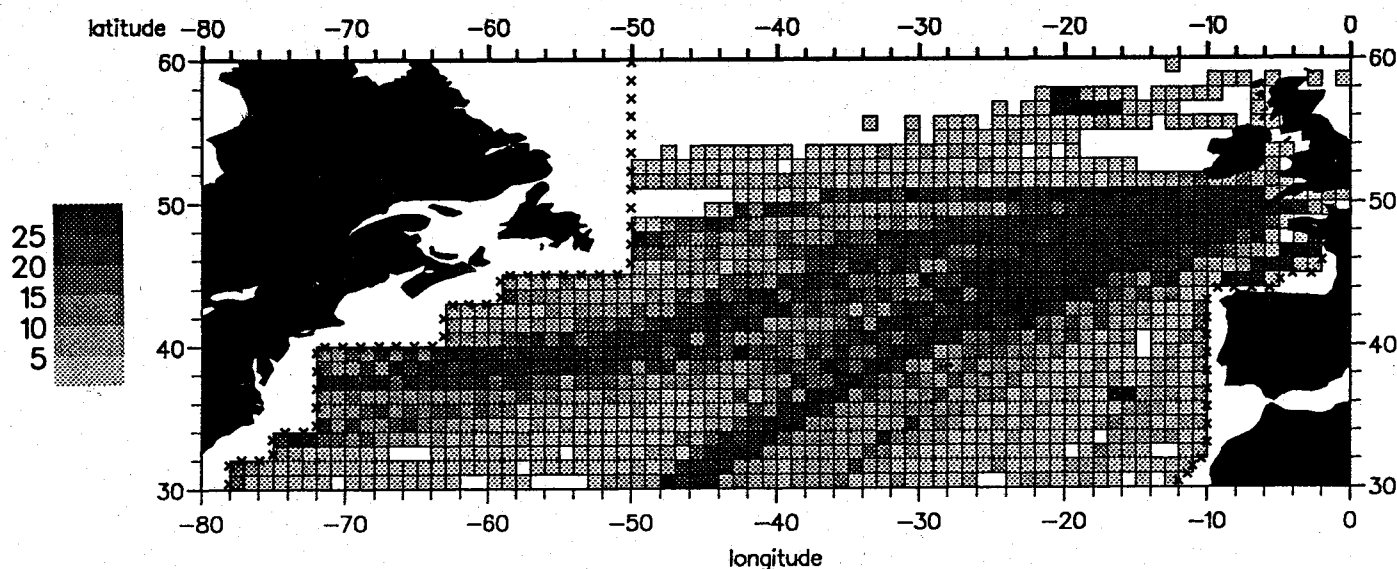

Figure 1. Distribution of observations for the final data set. The scale is in number of reports per one degree square in the final data set.

The data analysis was conducted jointly at the Meteorological Office and at the James Rennell Centre for Ocean Circulation. The main aim was to determine the effect of different observing practises on measurement accuracy, and whether any improvement might be gained by reporting extra information or by changing observing practises. The method used was to calculate and compare the mean differences between the observations and the model values, the latter being used purely as a comparison standard rather than as any indication of the "true" value. The results were classified according to observation method and also according to the recruiting country. Since the VOS are variously recruited by the marine meteorological agencies of member countries of the WMO, it was considered important to determine whether the different national procedures and preferences gave rise to systematic biases in the data.

Although not specifically taking part in the VSOP-NA the data from the weather ship *OWS Cumulus* stationed at ocean weather station Lima (57.5°N, 20°W) was included in the study for comparison purposes. During the VSOP-NA observation period the *Cumulus* conducted the normal activities of a weather ship but was also equipped with automatic meteorological instrumentation furnished by the Institute of Oceanographic Sciences/James Rennell Centre. It was hoped to use the *Cumulus* to determine the absolute accuracy of the ship reports, however these results must be interpreted carefully since the observations from the *Cumulus* are accorded greater importance in the model assimilation scheme (see Kent et al., 1991).

3. SUMMARY OF THE VSOP-NA SHIP CHARACTERISTICS

3.1 Names and Call Signs of the VSOP-NA ships

The ships recruited for the VSOP-NA project and their call signs are shown in Table 2. In this and succeeding tables and figures the ships are shown in alphabetical order of the recruiting countries (divided by horizontal lines) and, for a given country, of the ships' call signs¹.

3.2 Period of Participation in the VSOP-NA

The start and end dates of each ships participation in the VSOP-NA is given in Table 2 together with the the number of observations from each ship which were included in the VSOP-NA data set. Figure 2 (page 10) shows the frequency of reports received from each ship and illustrates that the different countries participating in the VSOP-NA were able to begin recruitment at varying times, and also that not all the recruited ships were able to participate throughout the VSOP-NA project.

Thus, referring to Figure 2, the **Canadian** recruited ship, *Irving Forest* (call sign VSBG8), reported reliably until being lost at sea, fortunately with no loss of life. The **French** recruited ships joined the project in 1989. By far the most frequent reports were from the *Edouard L.D.* (FNFD), a liquid gas tanker operating between Brittany and the Mediterranean. Unfortunately many of the reports were close to the Spanish coast and had to be excluded from the VSOP-NA data set in order

¹Confusion as to the correct callsign for Sealand Atlantic KRLZ (in one dataset it was entered as KLRZ) has resulted in this ship being out of order alphabetically in the diagrams.

Table 2. List of ships participating in the VSOP-NA according to recruiting country. The last two column represents the main and intermediate reporting efficiencies in percent (see text for details).

Country	Ship	Call Sign	Start		End		No. obs	Main Eff. %	Inter. Eff. %
			day	year	day	year			
Canada	Irving Forest	VSBG8	40	1989	324	1989	439	94	0
France	Ariana	DIDA	89	1989	237	1990	228	95	9
	C R Libreville	FNCZ	114	1989	205	1990	133	84	1
	Atlantic Cartier	FNEF	113	1989	268	1990	653	72	1
	Edouard L D	FNFD	103	1989	263	1990	766	64	65
	Le Carabie	FNGM	100	1989	219	1990	81	63	6
	La Fayette	FNGS	156	1989	32	1990	16	67	0
	Jean Charcot	FNOY	163	1989	295	1989	271	86	85
Germany	Independent Endeavor	DDLN	265	1988	71	1990	751	71	0
	Euro Texas	DDUC	317	1988	64	1989	148	95	0
	Nurnberg Atlantic	DHNE	250	1988	128	1990	981	86	8
	Alemania Express	DHRG	304	1988	106	1990	772	87	1
	America Express	DIMC	289	1988	136	1990	721	88	0
	Independent Concept	DNBR	285	1988	123	1989	459	85	0
	Independent Pursuit	DNJR	244	1988	121	1990	599	50	0
Netherlands	AEL America	PCEL	325	1988	64	1989	259	99	0
	Gulf Speed	PELT	144	1988	254	1988	153	87	0
	Gulf Spirit	PELU	122	1988	253	1988	175	88	0
	Nedlloyd Kingston	PGDG	278	1988	124	1990	473	96	0
	Nedlloyd Kyoto	PGDS	262	1988	58	1990	422	97	1
	Nedlloyd Zeelandia	PGDW	361	1988	130	1990	197	92	0
	Nedlloyd Neerlandia	PGEG	120	1988	92	1990	443	92	0
OWS (UK)	Cumulus	LIMA	282	1988	208	1990	3846	100	99
UK	Atlantic Link	C6DS	337	1988	23	1990	511	89	0
	Author	GBSA	245	1988	155	1990	456	94	12
	Geestbay	GBVV	252	1988	214	1990	1001	72	45
	Geestport	GBVW	267	1988	201	1990	944	76	43
	Geestcape	GJMR	259	1988	193	1990	1184	85	58
	Geesthaven	GJMS	273	1988	180	1990	868	74	44
	CGM Provence	GXES	280	1988	189	1990	1141	97	27
	Atlantic Conveyor	GZMM	27	1988	168	1990	809	88	0
	Nickerie	VRAZ	242	1988	179	1990	553	97	0
	CanMar Ambassador	VSBV3	258	1988	186	1990	1337	95	90
USA	Americana	IBPA	227	1989	248	1989	34	97	0
	Sealand Atlantic	KLRZ	58	1989	363	1989	415	86	0
	Julius Hammer	KRGJ	62	1989	56	1990	349	92	1
	Margarette Lykes	KRJL	92	1989	147	1990	539	85	0
	Sheldon Lykes	KRJP	50	1989	246	1989	299	81	0
	Sealand Commitment	KTPB	65	1989	35	1990	522	92	0
	Delaware Bay	WMLG	19	1989	310	1989	276	72	0
	Adabelle Lykes	WPFZ	59	1989	343	1989	359	90	0
	Charlotte Lykes	WPHZ	38	1989	50	1990	709	87	0
	Galveston Bay	WVPF	72	1989	92	1990	609	94	1
	Nedlloyd Hudson	WPWH	90	1989	51	1990	427	93	0
	Lyra	WSDG	280	1989	45	1990	124	87	0

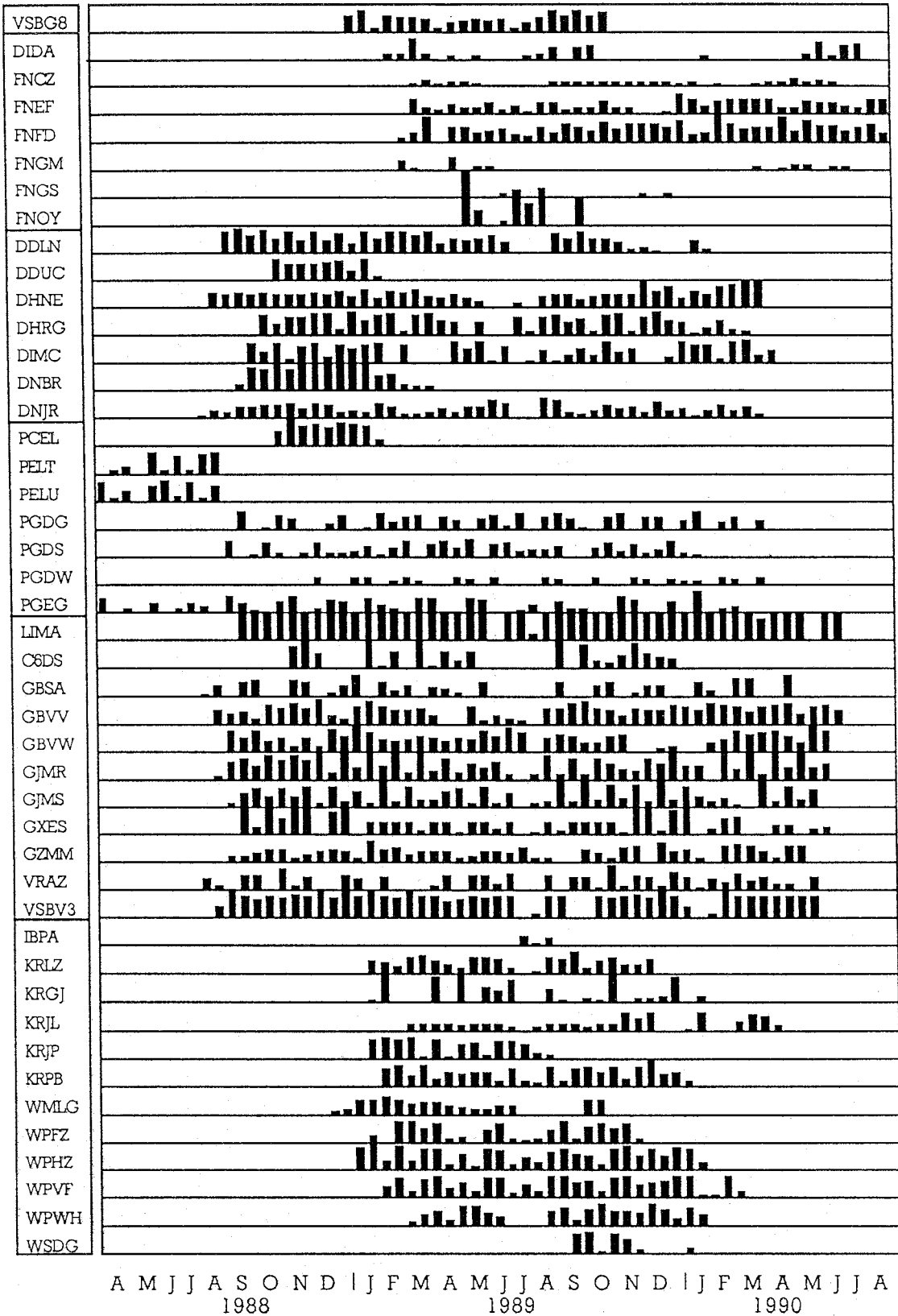

Figure 2. The distribution of observations in the VSOP-NA data set as a function of time. The vertical scale of the histogram bars is from 0 to 40 (or more) observations during a 2 week period.

to avoid the use of misleading values from the Meteorological Office model. The research ship *Jean Charcot* (FNOY) also reported frequently until being taken out of service following a fire. Two **German** recruited ships, *Euro Texas* (DDUC) and *Independent Pursuit* (DNBR) left the project early; the other German recruited ships reported reliably throughout. The **Netherlands** succeeded in recruiting ships very early in the project but the two ships, *Gulf Speed* (PELT) and *Gulf Spirit* (PELU) were sold and left the project after a few months. Most of the **UK** recruited ships reported reliably throughout the project until April 1990 when it was considered that a suitable data set had been obtained. The **USA** recruited ships did not begin reporting until January 1989, but the generally reported reliably. Unfortunately delays in receiving the data meant that many USA ship observations from January 1990 onwards were received too late to be included in the data set.

3.3 Reporting Efficiency

The reporting "efficiency" shown for each ship in Table 2 and Figure 3a, was calculated by assuming that the ship could have returned 4 main reports per day (0000, 0600, 1200, 1800 GMT) during the period that it participated in the VSOP-NA, excluding periods when the ship was in port or outside the area of the Meteorological Office fine-mesh forecast model. The average efficiency of the VSOP-NA ships, defined as above, is 86%. These efficiencies include periods when navigational requirements exclude other duties and therefore an efficiency of 100% would not be expected (except for an OWS on station). In addition, some ships reported intermediate reports (0300, 0900, 1500 and 2100 GMT) and the percentage of the possible intermediate reports made is also given in Table 2 and Figure 3a.

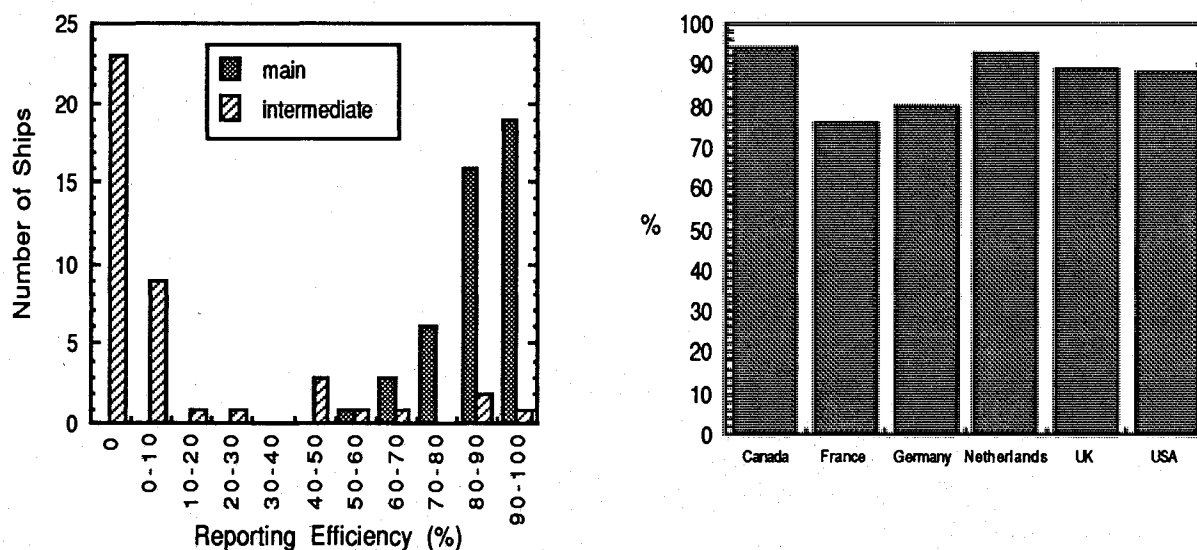

Figure 3 (a) Histogram showing the reporting efficiencies of the VSOP-NA ships.
 (b) The mean reporting efficiency for main reporting hours of ships recruited by the various participating countries.

3.4 Ship Routes

The ship routes used by the VSOP-NA ships were constrained by the requirement that the chosen ships should mainly operate in the North Atlantic. The overall distribution of VSOP-NA ship reports (shown in figure 1) indicated that the VSOP-NA ships mainly plied a number of routes which are listed in table 3 and illustrated in figure 4.

The geographical distribution of observations for each ship is shown in the ship catalogue (section 5), and summarised in table 4 (page 14). Although most of the routes included the Western Approaches to the English Channel, and contributed observations in the northeast part of the VSOP-NA area, observations in other regions were obtained from ships on only one or two of the main routes. This resulted in significant variations in the geographical distribution of the observations when classified according to the different ship recruiting countries. This is shown in Figure 5 (page 15).

Referring to figure 5, the reports from the one **Canadian** recruited ship, *Irving Forest*, were from the Canada route, and provided reports in the Northwest Atlantic region of the VSOP-NA area, as did reports from **French** recruited ships. However the data set of observations from the French ships was dominated by reports from the *Edouard L.D.* (in the Bay of Biscay on route from Brittany to the Mediterranean), and the *Jean Charcot* (a research ship which spent some time in the region of 42°N 16°W). Other French reports were from routes in the Southeast region, and few or no reports were obtained from the Mid South. In contrast, the **German** recruited ships provided observations on the Europe to USA routes with no observations in the Southeast region. The **Dutch** recruited ships provided reports over all regions except the Northwest (Europe to Canada route) with most reports in the Mid South region. Observations from the **British** recruited ships were dominated by the Caribbean route, giving observations in the Mid South region, but there were also significant numbers of observations from the Southwest and Northwest regions with only the Southeast region being sparsely sampled. The **USA** recruited ships provided observations in all regions except the Northwest.

Table 3 Main routes plied by the ships participating in the VSOP-NA. The last column gives the region of the VSOP-NA area for which the observations predominantly came from ships on these routes.

	To/from	From/to	Region
1	Europe	Canada (Newfoundland, St Lawrence, Nova Scotia region)	Northwest
2	Europe	East Coast USA (Boston, New York etc.)	Southwest
3	Europe	Straits of Florida (N Gulf region)	
4	Europe	Caribbean (West Indies, Gulf of Mexico, Panama Canal)	Mid South
5	Europe	S.America	
6	Europe	Mediterranean	Southeast
7	Europe	Cape of Good Hope	
8	E.Coast USA	Mediterranean	(Southwest to southeast regions)

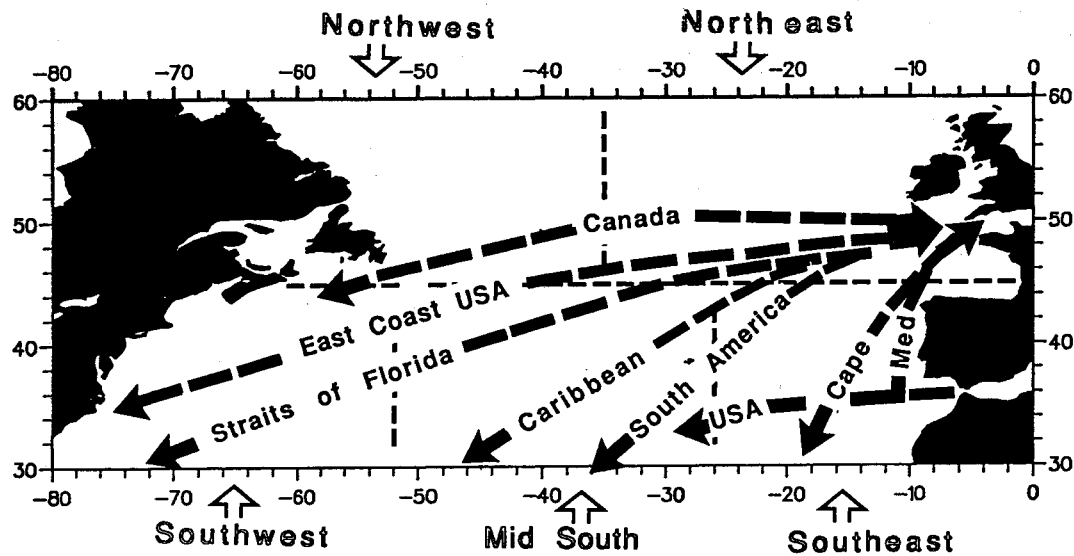

Figure 4 Regional division of the VSOP-NA area and the approximate location of the main shipping routes.

3.5 Ship Type

Table 5 shows the types of the 45 ships recruited for the VSOP-NA both overall and for the individual recruiting countries. The VSOP-NA requirement that the ship should mainly operate in the North Atlantic led to the selection of mainly container vessels and the exclusion of most tankers.

Table 5. Summary of the type of ships recruited to the VSOP-NA, overall and by recruiting country

Type	All	Canada	France	Germany	Neth.	UK	USA
Container	29		4	7	7	3	11
Ro-Ro Container	2		1			1	
Closed Container	1					1	
Container/Banana	5					5	
Tanker	1						1
Gas tanker	1		1				
General Cargo	1	1					
Research Ship	1		1				
Weather Ship	1					(1)	
All types	45	1	7	7	7	10 + (1)	12

Table 4. Summary of most usual routes for each ship. Route names refer to the positions from which observations were received and are not necessarily the ship's origin or destination.

	Europe to							USA to Med.
	Canada	East Coast	Straits of Florida	Caribbean	South America	Med.	Cape	
VSBG8	✓							
DIDA							✓	
FNCZ								✓
FNEF	✓							
FNFD						✓		
FNGM				✓				
FNGS							✓	
FNOY						✓	✓	
DDLN		✓						
DDUC			✓	✓				
DHNE	✓							
DHRG		✓						
DIMC		✓						
DNBR		✓						
DNJR		✓						
PCEL		✓						
PELT		✓						
PELU		✓						
PGDG				✓	✓			
PGDS				✓	✓			
PGDW							✓	
PGEG				✓	✓			
LIMA	At Ocean Station Lima (20°W 57.5°N)							
C6DS	✓	✓						
GBSA				✓	✓			
GBVV				✓				
GBVW				✓				
GJMR				✓				
GJMS				✓				
GXES		✓		(✓)				
GZMM	✓							
VRAZ					✓			
VSBV3	✓							
IBPA	✓	✓						
KLRZ								
KRCJ								✓
KRJL		✓	(✓)					
KRJP		✓	(✓)					
KRPB		✓						
WMLG		✓						
WPFZ		✓	(✓)					
WPHZ		✓	(✓)					
WPVF		✓						
WPWH		✓						
WSDG		✓	✓					

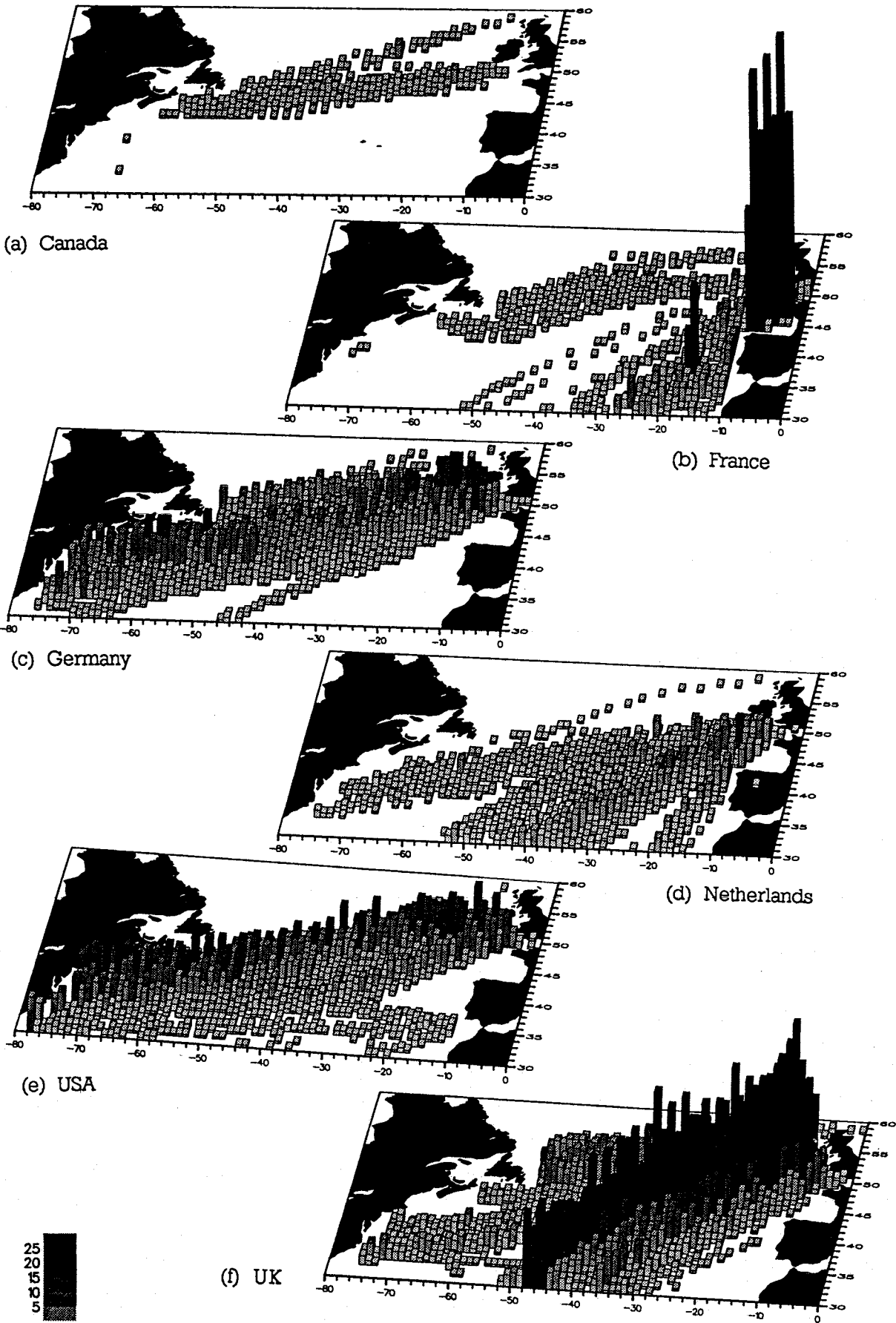

Figure 5 The geographical distribution of reports from the VSOP-NA ships, classified according to the recruiting country. The scale is in number of reports per one degree square during the project.

3.6 Ship Size

The length of each of the VSOP-NA ships is shown in figure 6, together with a histogram showing number of ships in each length category. The most likely length was between 200 and 225m. The UK recruited ships were generally smaller than this, the USA recruited ships were that size or larger.

There is no published table of the lengths of ships in the VSOP-NA fleet as a whole, however figure 7 shows that, for the VSOP-NA ships, the height at which the temperature was measured was, as might be expected, roughly related to the length of the ship. For 4378 of the 7491 VOS ships, WMO (1990) contains the heights of the observing platforms (where for most ships the temperature is measured), so this variable can be used to compare the VSOP-NA ships with a large fraction of the VOS fleet. The peak of the histogram for the VSOP-NA ships (Figure 8) corresponds to a significantly greater height than that for the VOS fleet, suggesting that the VSOP-NA ships tended to be larger than is typical. This is probably because of the selection of ocean going container vessels, and the exclusion of small coastal vessels, for the VSOP-NA project.

3.7 Ship Speed

For each ship the mean speed at the time of the observation is shown in figure 9. The most likely speed was 16 to 18 kts which, given the larger size of the VSOP-NA ships, is likely to be higher than average for the VOS fleet.

3.8 Variation in Sensor Heights

In order to determine changes in sensor height, the instrument heights on each VSOP-NA ship were specified with respect to a reference level (for example the main deck level, or mean sea level) and the height of this reference level above the actual sea surface was reported with each observation. Unfortunately this variable was not always reported correctly since some ships reported a constant value throughout the project, which is very unlikely. For those ships which did report changes, the variation in the reference level height was usually about 2m, extending to about 5m for certain of the larger ships. This represents the amount by which the ship was higher or lower in the water depending on the amount of cargo and fuel carried. For some ships this variation was regular, corresponding to the ship being more lightly laden when travelling in one direction compared to its return. In addition to this regular 2 to 5m variation the data from some ships indicated jumps of 10m or more. Whether this represents journeys with the ship in ballast or errors in the value reported for the reference level is not known.

Variations in the deck cargo height will alter the nature of airflow over the ship and may therefore affect anemometer measurements of wind velocity and possibly also the temperature and humidity measurements. For each ship, the height of the deck cargo above the main deck and the amount of variation are shown in figure 10.

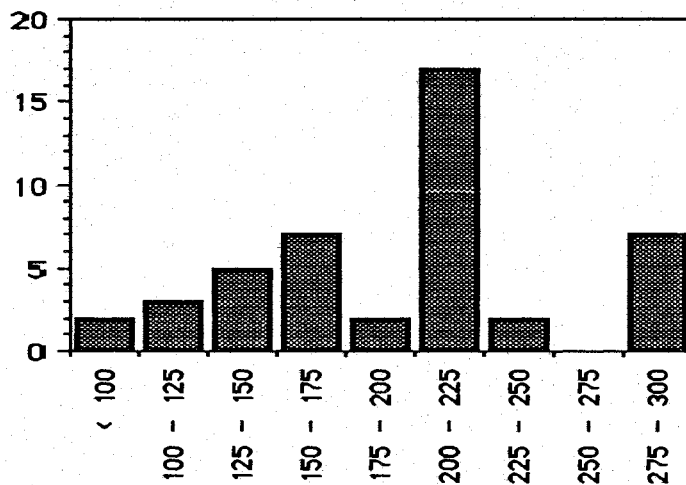
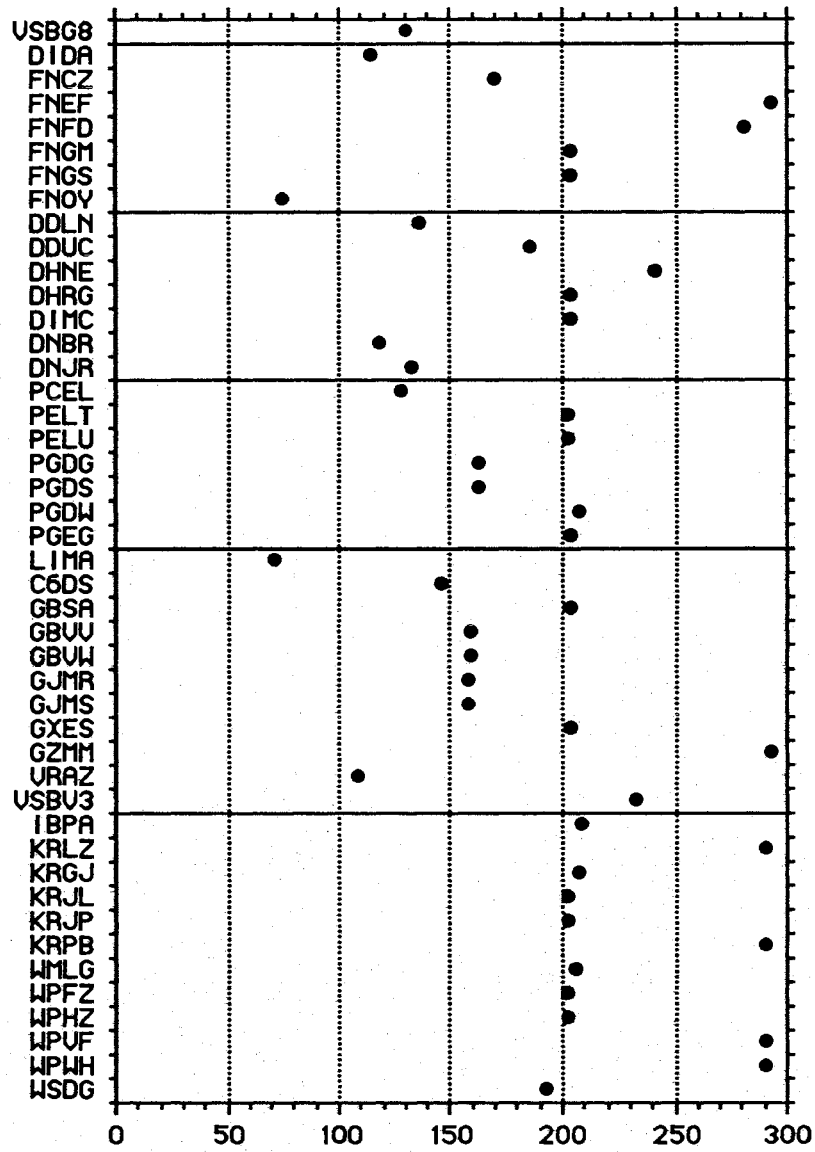

Figure 6. (a) The length of each of the VSOP-NA ships (metres).
 (b) histogram showing number of ships in each length category for the VSOP-NA ships.

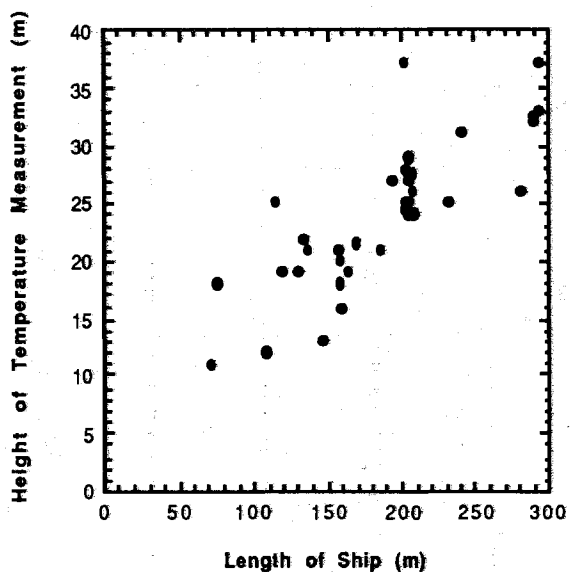

Figure 7 Relationship between the height of the temperature measurement and the length of the ship.

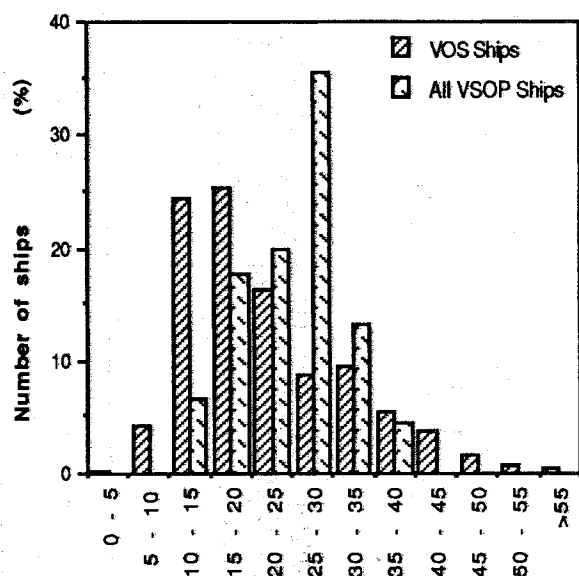

Figure 8. Histograms of the distribution of temperature measurement heights on the VSOP-NA ships and of the observing platform height on the VOS ships.

4. INSTRUMENTATION SUMMARY

4.1 Winds

4.1.1 Technique Used

Wind speeds are estimated visually from sea state ("Beaufort" estimates) or measured by fixed or handheld anemometers. The percentage of ships in the VSOP-NA project and in the VOS fleet as a whole which use each method is shown in Table 6. Of the VSOP-NA countries, **Germany**, the **Netherlands**, and the **UK** require ships officers to give visual estimates. Compared to anemometer measurements, this technique is considered to represent an integration of the wind speed and direction over the past hour or so, rather than a spot value. It also avoids effects such as errors due to ship motion, sheltering of the measurement site, or air flow disturbance over the ship. The **USA** recruited ships used visual estimates or fixed anemometers, the **Canadian** ship used a fixed anemometer, and the **French** ships used either fixed or hand-held anemometers. Fixed anemometers might be considered to provide a more objective wind measurement provided that the sensors are well maintained and calibrated, and properly exposed. The supplied plans and photographs (section 2.3) suggested that in general the fixed anemometers were well exposed, often being positioned high on the signal mast. The quality of exposure of handheld anemometers is difficult to estimate.

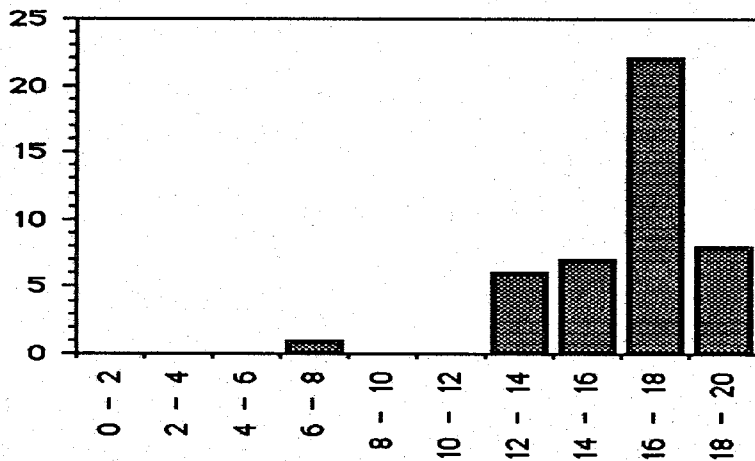
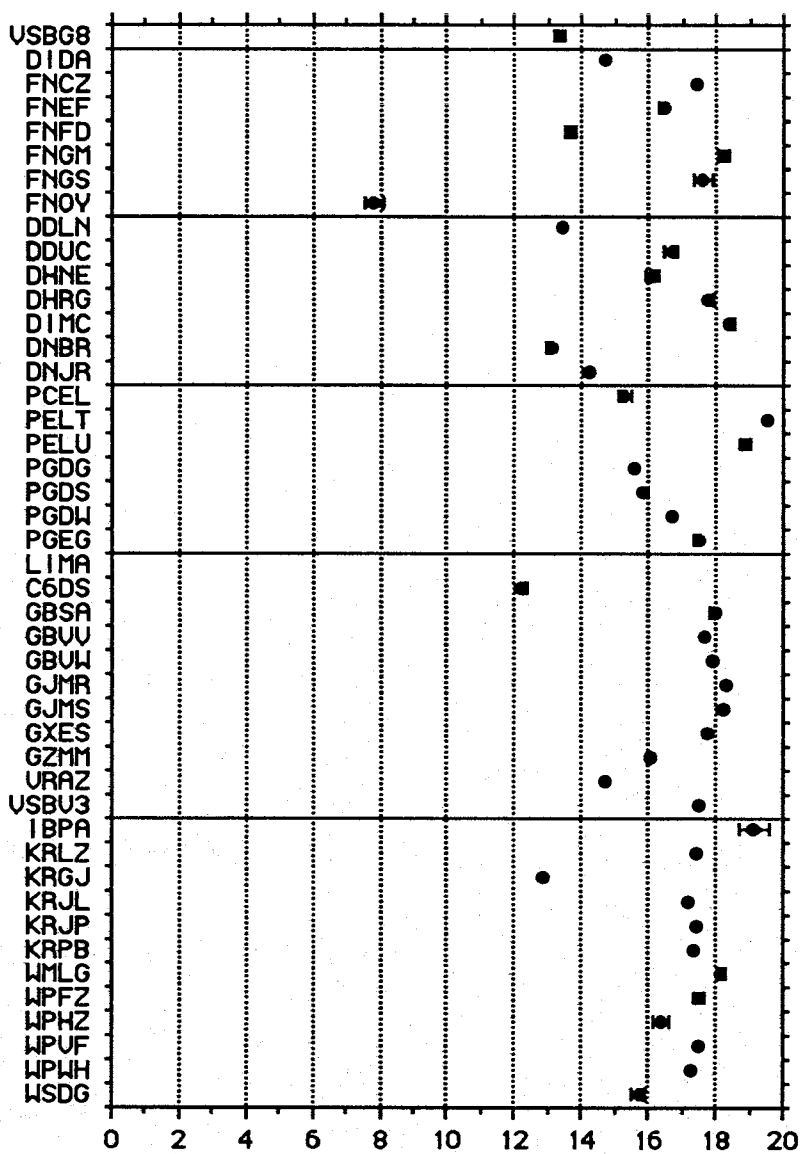

Figure 9. Speed of the ship at the time of observation (kts):
 (a) mean value for each ship
 (b) numbers of ships with mean speeds in the ranges shown.

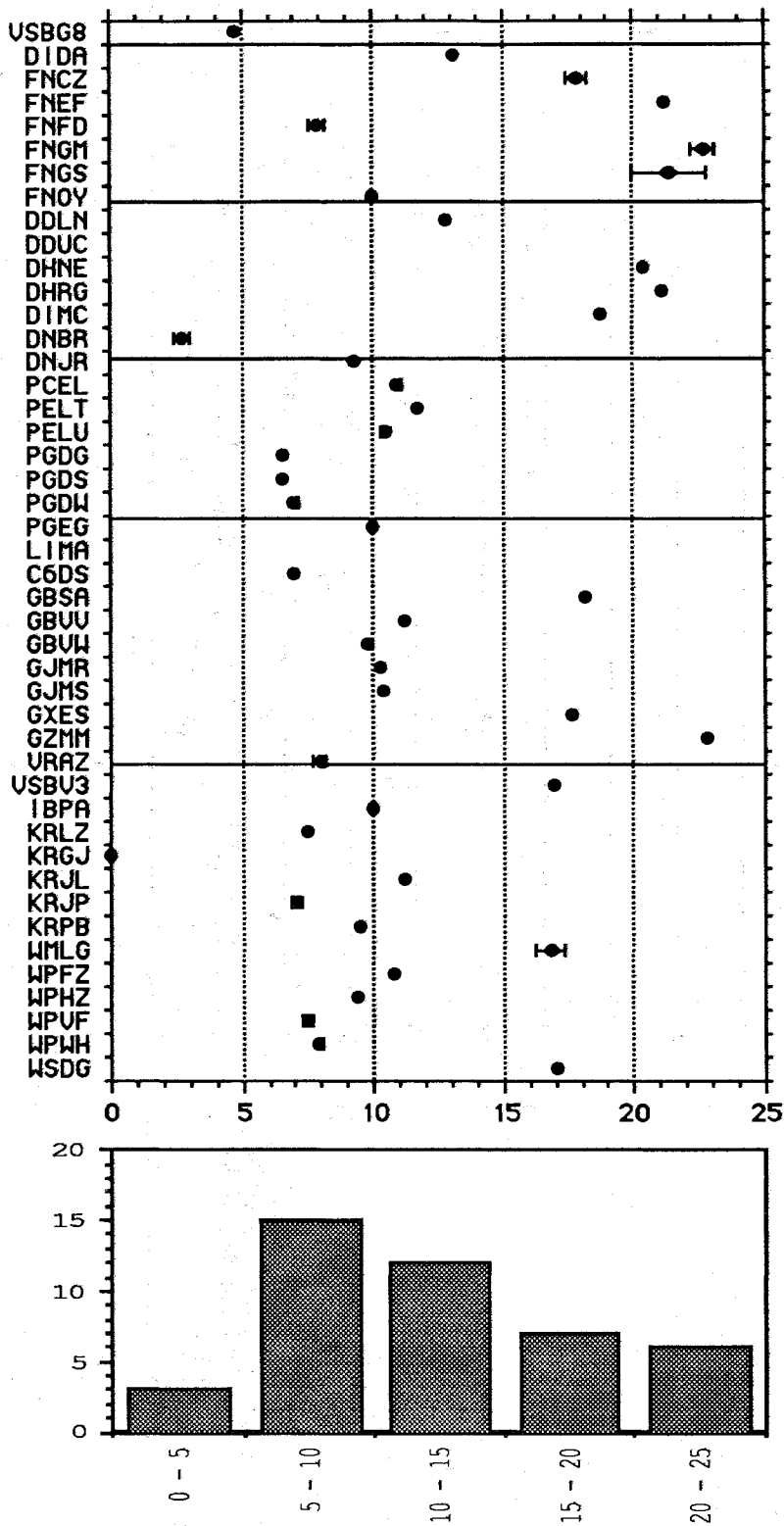

Figure 10. Height of cargo above main deck (m):
 (a) height and reported variation for each ship
 (b) numbers of ships with cargo heights in the ranges shown.

Table 6. Measurement technique used for wind observations for the VSOP-NA ships and for the VOS fleet as a whole.

Country	No. of Ships		Fraction of each fleet (%)						No. Unknown
			Visual		Fixed		Handheld		
	VSOP	VOS	VSOP	VOS	VSOP	VOS	VSOP	VOS	VSOP
Canada	1	424	0	10	100	87	0	3	0
France	7	153	0	0	43	49	43	50	1?
Germany	7	597*	100	96	0	4	0	0	0
Netherlands	7	273	100	100	0	0	(14)**	0	0
UK	10	464	100	100	(50)**	0	0	0	0
USA	13	1470	31	74	23	26	0	0	6
All ships	45	7491	63	70	17	22	7	8	13

* Combined East and West German Fleets
 ** Not used for wind measurement.

The statistics for the **VOS** fleet as a whole, shown in Table 6, were obtained from the "List of Selected Ships" (WMO, 1990). 70% of the VOS are listed as not being equipped with anemometers and it is assumed that these ships report visual estimates, compared to a figure of 63% for the VSOP-NA. The fractions of ships using fixed and handheld anemometers in the VSOP-NA and the VOS fleet are also similar (17% against 22% for fixed, 7% against 8% for handheld). Unfortunately the accuracy of the WMO (1990) figures is known to be questionable. For example 50% of the UK recruited VSOP-NA ships carried fixed anemometers. Although the VSOP-NA ships reported that the anemometers were not used for meteorological reports, Ive (1987) found that in the mid 1980's, 11% of observations from UK recruited VOS were reported to be anemometer measured winds (other figures were Canada 58%, France 88%, FRG 10%, Netherlands 3%, USA 49%). There is also the question of to what degree, if any, visual winds are influenced by the availability of an anemometer reading.

4.1.2 Height of Measurement

The height in metres above mean sea level of the anemometers for the VSOP-NA ships is shown in figure 11. All anemometers carried are shown, although in the case of the UK and Dutch ships the anemometers were only used for docking purposes. Visual estimates are shown at 10m, which is the effective height for VOS estimates using Beaufort scale WMO 1100 as specified for the VOS (WMO, 1970). The anemometer heights for the VSOP-NA ships are compared to those for the VOS fleet as a whole in figure 12. The most likely height for the VSOP-NA ships was about 30m, considerably higher than the value for the whole VOS fleet of about 15 to 20 metres. This was due to the larger size of the VSOP-NA ships (section 3.6). Inspection of figures 11 and 12 emphasises that the use of anemometers on large, modern ocean going ships will increase the measurement height for winds compared to the visual estimates.

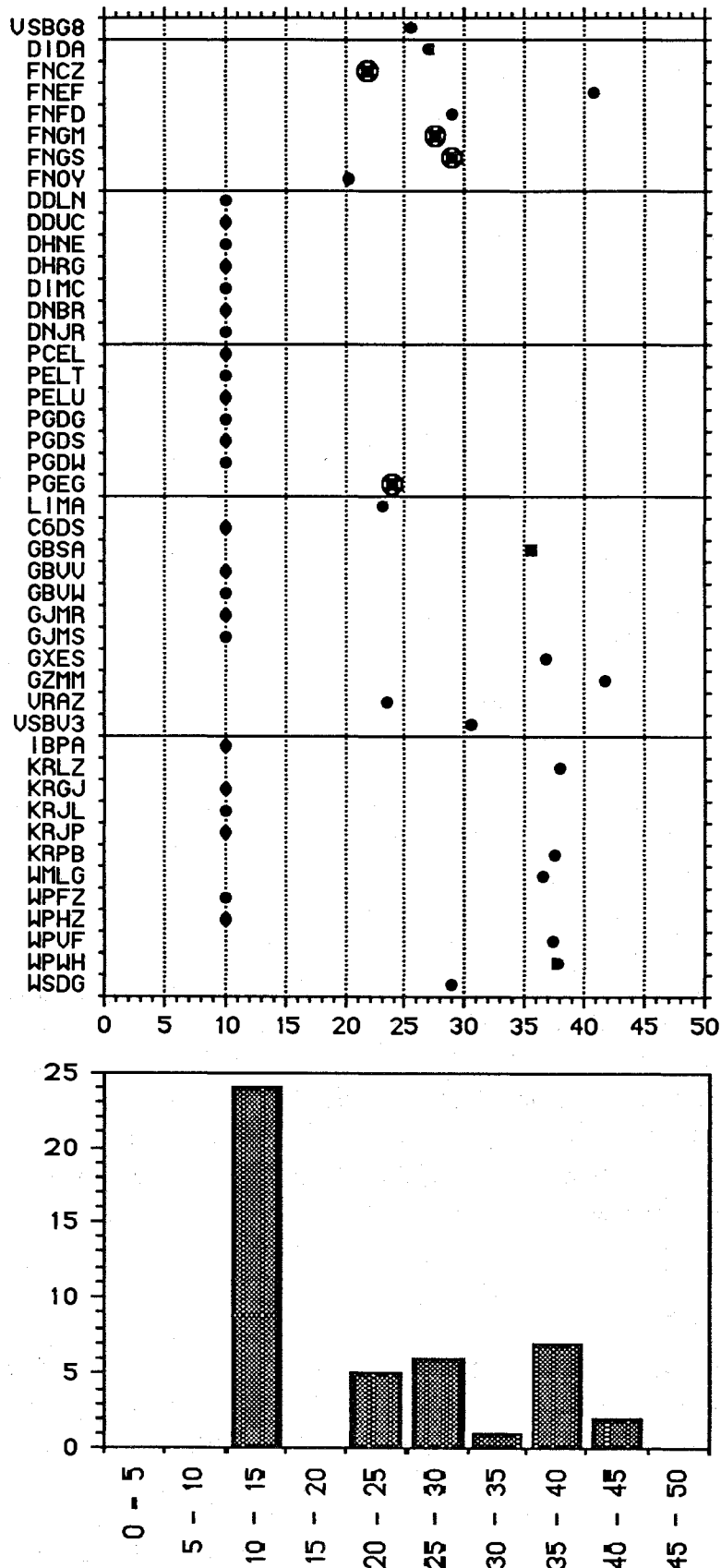

Figure 11 Height of the anemometer (m) or effective height of visual wind estimate:
 (a) height and reported variation for each ship
 (b) numbers of ships with wind measurement heights in the ranges shown.
 Visual estimates are shown at 10m, handheld anemometers are ringed.

4.1.3 Types of Instruments

The anemometers carried by the VOS have usually been fitted by the ship operators for docking purposes and will vary considerably. Where instruments are recommended or fitted by meteorological agencies the European countries tend to favour cup anemometer and wind vanes whereas the US use propeller-vane instruments. The French recruited ships either used cup anemometers (figure 13a - c) or handheld anemometers (figure 13d).

4.2 Air Temperature and Humidity

4.2.1 Technique Used

Air temperature and humidity measurement on the VSOP-NA ships was by dry and wet bulb thermometers housed in a Stevenson screen or used in a sling psychrometer. Mostly the thermometers were mercury-in-glass which require manual reading, however on 3 French recruited ships platinum resistance thermometers (PRT's), allowing a remote readout, were installed. Screens require a well exposed position for good ventilation and usually two screens must be installed to either side of the ship, normally on the bridge wing or wheelhouse top. Of the 21 VSOP-NA ships using screens, 8 were only equipped with one screen. Observations obtained using a handheld psychrometer were normally taken from the windward¹ bridge wing. These "sling psychrometer" instruments are swung to drive air over the thermometer bulbs; a disadvantage is that the thermometers are easily broken.

Table 7. Measurement technique used for temperature and humidity observations for the VSOP-NA ships and for the VOS fleet as a whole. For the latter, only the VOS which observe humidity are included (about half the VOS fleet).

Country	No. of Ships		Fraction of each fleet (%)						No. Unknown
			Screen		Psychrometer		Unscreened		
	VSOP	VOS	VSOP	VOS	VSOP	VOS	VSOP	VOS	VSOP
Canada	1	129	100	95	0	5	0	0	0
France	7	151	57*	42	43	58	0	0	0
Germany	7	596	0	<<1	100	>99	0	0	0
Netherlands	7	273	0	0	100	100	0	0	0
UK	10	459	100	>99	0	<<1	0	0	0
USA	13	393	46	18	8	82	0	<<1	46
All ships	45	3867	49	44	38	55	0	1	13

* of which 3 (43%) are remote reading screens containing PRT's and 1 (14%) is a conventional screen

¹ In bad weather it is possible that the leeward bridge wing is used, however no reports of this happening were received from the VSOP-NA ships. Errors could be introduced if the psychrometer is read in the wheelhouse after exposure on the Bridge Wing.

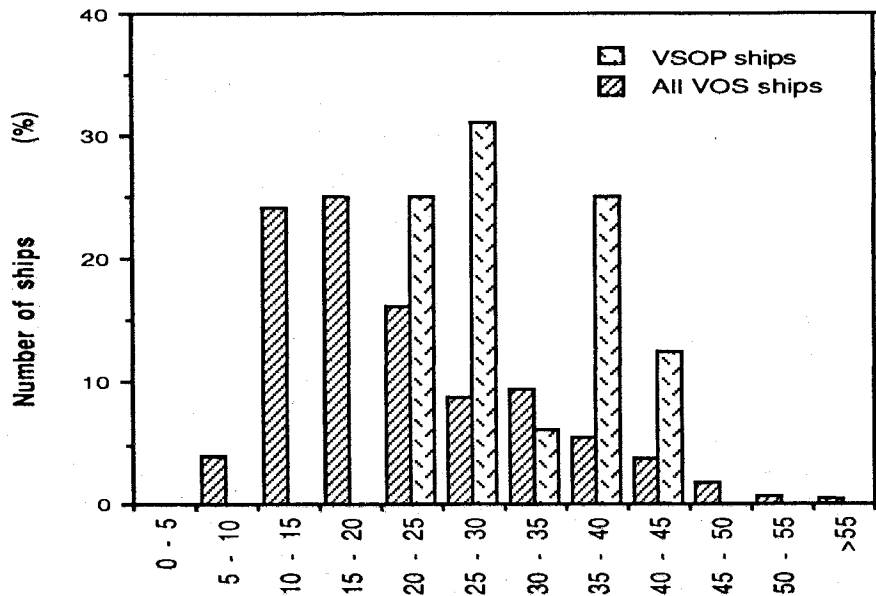

Figure 12 Anemometer heights for the VSOP-NA ships and for the whole of the VOS fleet.

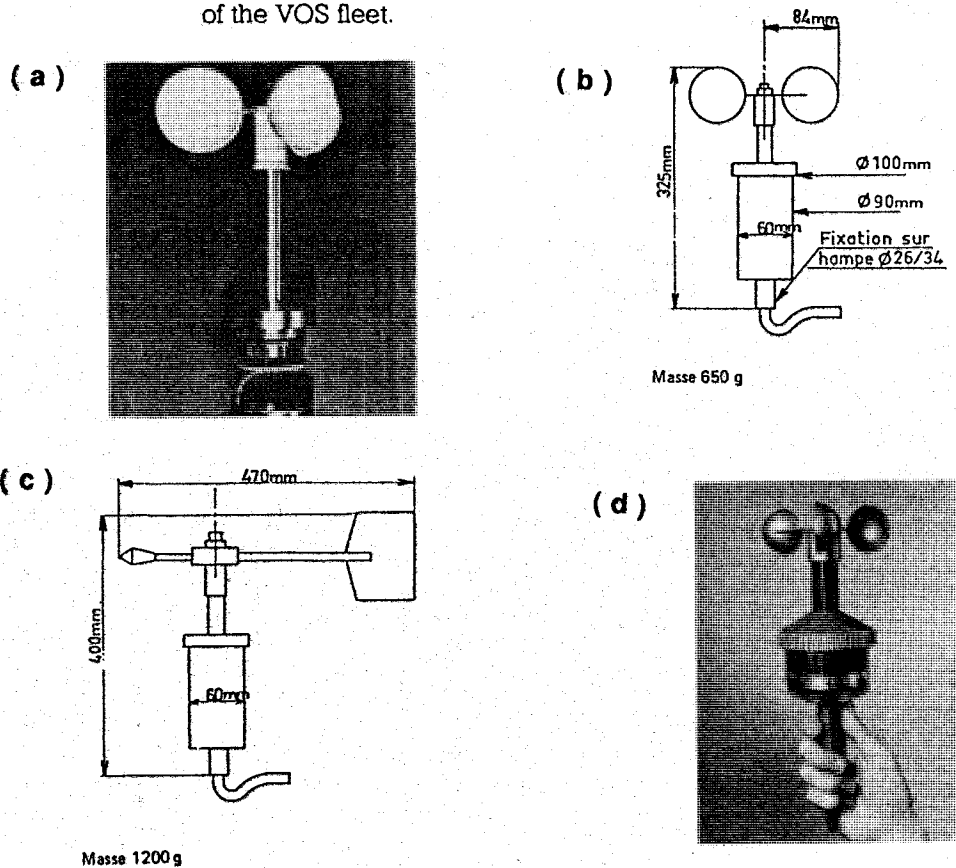

Figure 13 Types of anemometer used by the VSOP-NA ships. (a - c) Anemometer and wind vane of the "Pommar" met system (France). (d) Handheld anemometer (France).

Table 7 shows that about half the ships in the VSOP-NA used screens with the rest using psychrometers. Only about half the **VOS fleet** report humidity values, again about half these use screens and half use psychrometers. Of the different VSOP-NA recruiting countries, **Germany** and the **Netherlands** and the **USA** normally provide psychrometers, **Canada** and the **UK** provide screens, and **France** provides screens or psychrometers. The main difference between the VSOP-NA and VOS instrumentation was that nearly half the USA recruited VSOP-NA ships used screens whereas psychrometers are more usually used on American recruited VOS ships.

4.2.2 Height of Measurement

The height at which the measurements were taken on each VSOP-NA ship is shown in figure 14. It was shown in section 3.6 that the temperature measurement height is related to ship length and that the most likely measurement height on the VSOP-NA ships was higher than for the VOS fleet as a whole. Measurement heights were lowest on the Netherlands and UK recruited ships and highest in the German and USA ships.

4.2.3 Type of Instrument

Sling psychrometers used by the VSOP-NA ships are illustrated in figure 15(a) - (c). Screens used on the Canadian and British ships and on the French ships are shown in figure 15(d) and (e). The screens used on the USA recruited ships varied in design and effectiveness.

4.3 SST

4.3.1 Technique Used

Sea surface temperature measurements on the VSOP-NA ships were obtained using bucket, engine room intake or hull sensor thermometers. Additional instruments sometimes employed within the VOS fleet are expendable bathythermographs (XBT), and trailing thermistors.

Sea surface temperature buckets are normally lowered from the bridge wing to sample the surface water. Buckets were used on ships recruited by **Canada**, **Germany**, and the **Netherlands** and on about half of the **UK** ships. Hull contact sensors are being fitted to an increasing fraction of the VOS, but were only present on UK recruited VSOP-NA ships with 3 of the ships (the Geestbay, Geestcape, and Geesthaven) being fitted with sensors during the project¹. The engine room intake temperature is used predominantly on the VSOP-NA ships recruited by **France** and the **USA**. It is monitored routinely by all ships as the water is used as a coolant and some ships report either bucket or intake temperatures flagging the observation accordingly.

¹ Geestport had been fitted with a hull sensor prior to the project start.

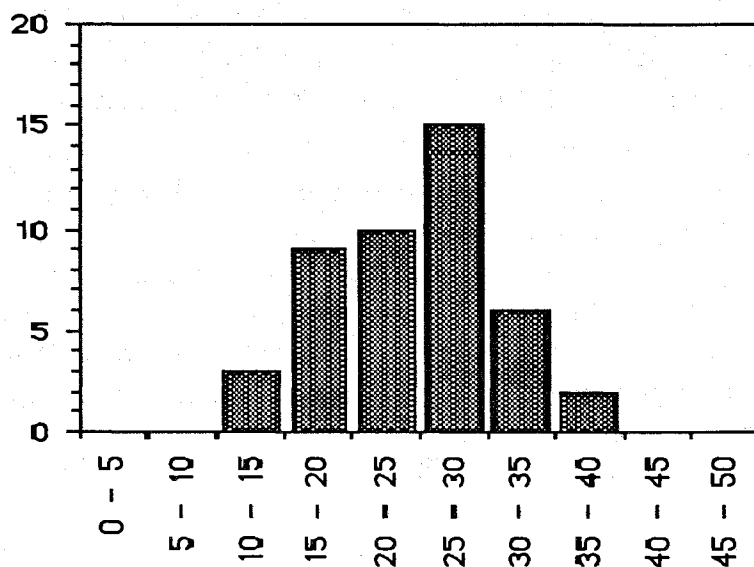
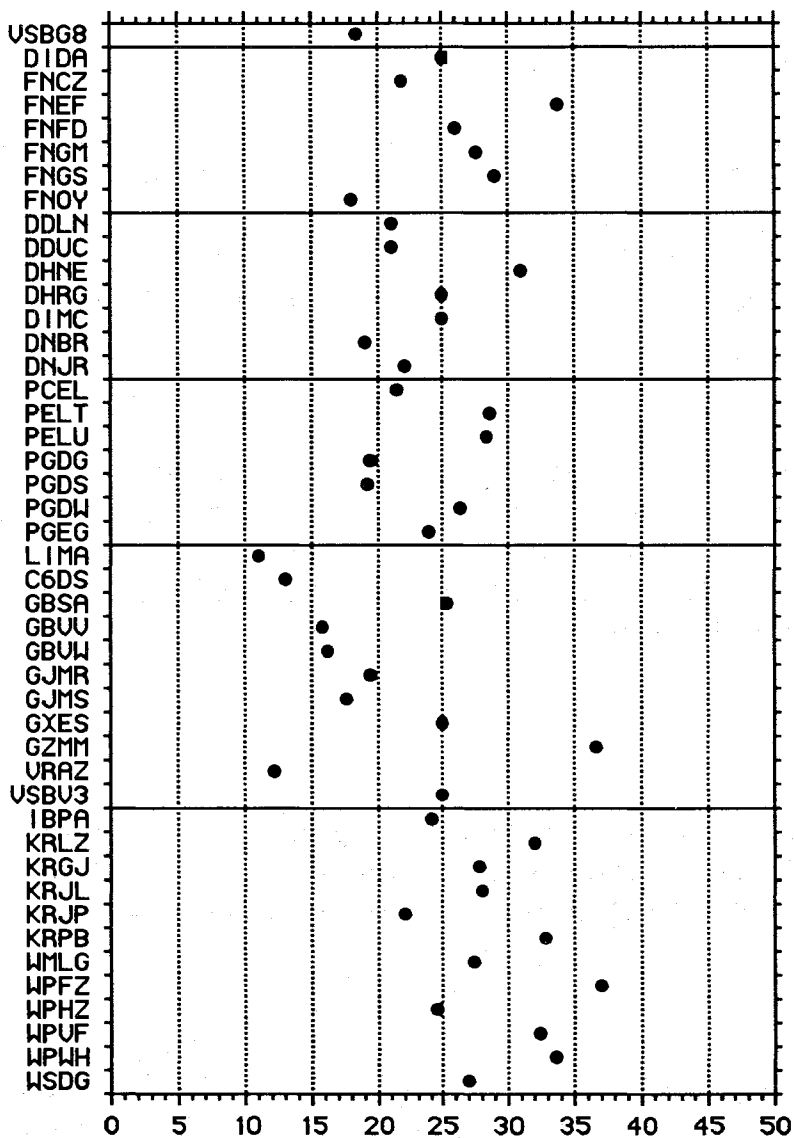
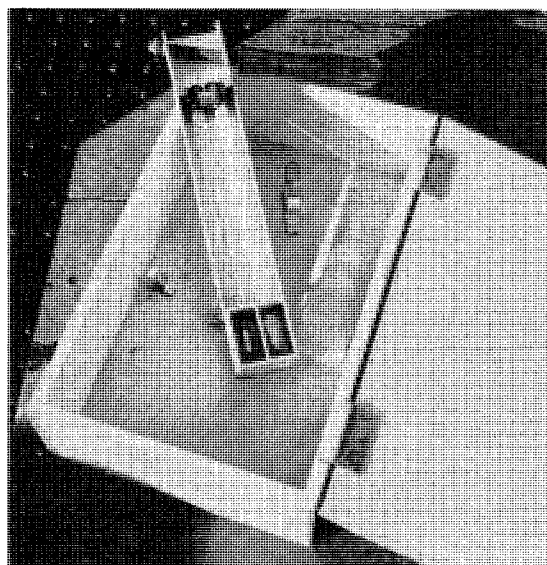
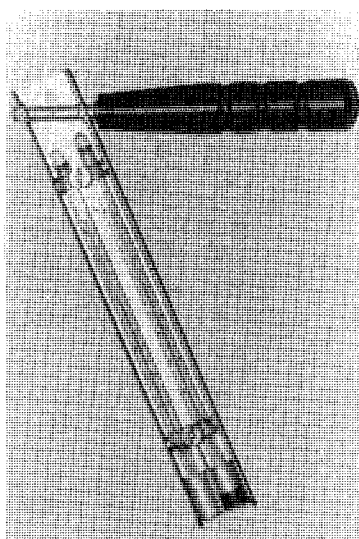

Figure 14 Height of the temperature and humidity measurements (m):
 (a) height for each ship
 (b) numbers of ships with measurement heights in the ranges shown.



(a)



(b)

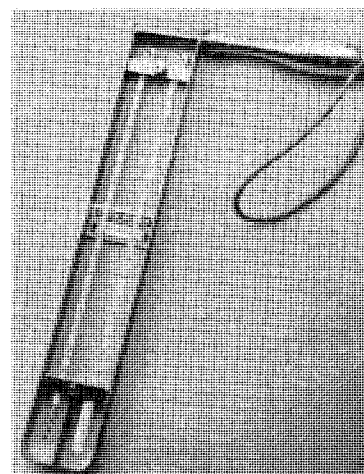

(c)

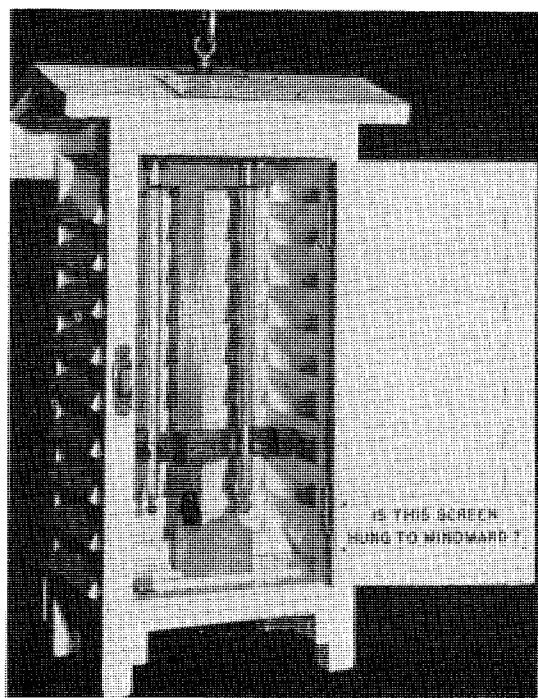

(d)

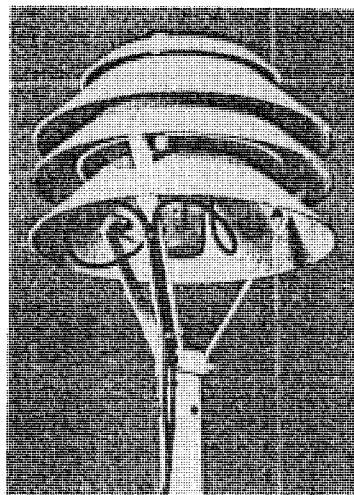

(e)

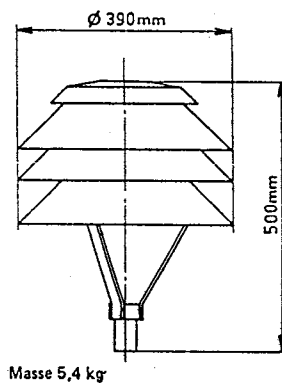

Figure 15 Temperature and humidity instruments on the VSOP-NA ships. Sling psychrometers: (a) KNMI, (b) Deutscher Wetterdienst, (c) French (U01-4230). Screens: (d) Canada, UK: Marine Screen Mk 1B (M.O., 1981), (e) Pommar Screen (France).

Table 8. Measurement technique used for sea surface temperature observations for the VSOP-NA ships and for the VOS fleet as a whole.

Country	No. of Ships		Fraction of each fleet (%)						No.	
			Bucket		Condenser or Engine Intake		Hull Sensor		Not known	Other
	VSOP	VOS	VSOP	VOS	VSOP	VOS	VSOP	VOS	VSOP	VOS
Canada	1	225	100	96	0	4	0	0	0	0
France	7	153	36	10	64	90	0	0	0	0
Germany	7	592	100	71	0	29	0	0	0	0
Netherlands	7	273	100	83	0	17	0	0	0	0
UK	10	445	52	87	18	3	30	9	0	0
USA	13	751	4	3	88	95	0	2	8	<1
All ships	45	6180	52	32	38	65	4	2	4	1

4.3.2 Depth of Measurement

For engine intake and hull sensor measurements the depth of the sea surface temperature measurement on the VSOP-NA ships was usually between 3 and 7 metres (figure 16). However subduction of water around the ships hull may result in an effective measurement depth which is nearer the surface. Sea temperature buckets are difficult to use from a high bridge wing and it is unlikely that water much below the surface is sampled. A measurement depth of 0 metres has been assumed, although mixing by the ship's bow wave may mean that the water sampled represents a greater depth.

4.3.3 Type of Instrument

Engine intake thermometers are normally part of the ship's equipment and will vary from ship to ship. They are not necessarily calibrated or designed to the precision desirable for meteorological measurements. They may be poorly sited with large parallax errors affecting the reading. The various types of sea surface temperature buckets used on the VSOP-NA ships are shown in figure 17. The hull contact sensor used on the UK recruited ships is a platinum resistance thermometer bonded to the inner skin of the hull, and insulated from the ship's internal temperature (MO, 1981). Details of hull sensors used by the Netherlands and the UK are attached to this report as Appendix 1.

4.4 Pressure

4.4.1 Technique Used

The VSOP-NA ships measured pressure measured either by using a digital Precision Aneroid Barometer or with an analogue barometer (Table 9). In addition many ships also carried a barograph.

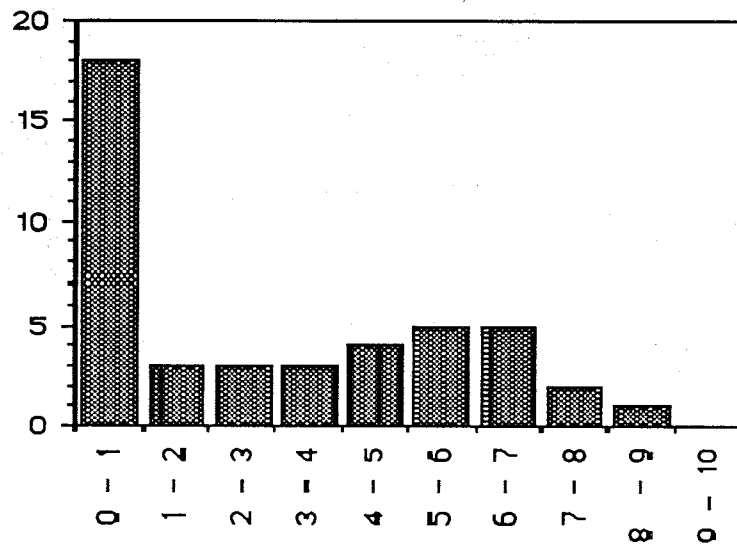
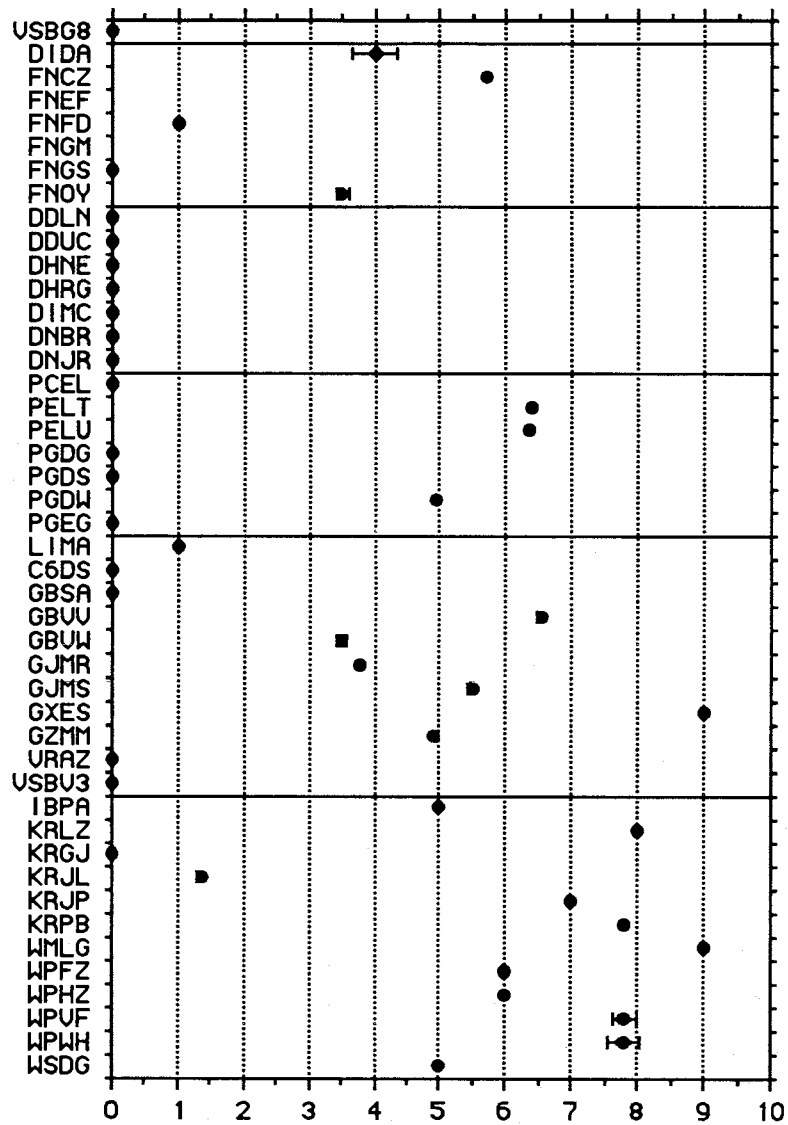

Figure 16 Depth of the sea surface temperature measurements (m):
 (a) depth for each ship (buckets are shown as 0 metres depth.)
 (b) numbers of ships with measurement depths in the ranges shown.

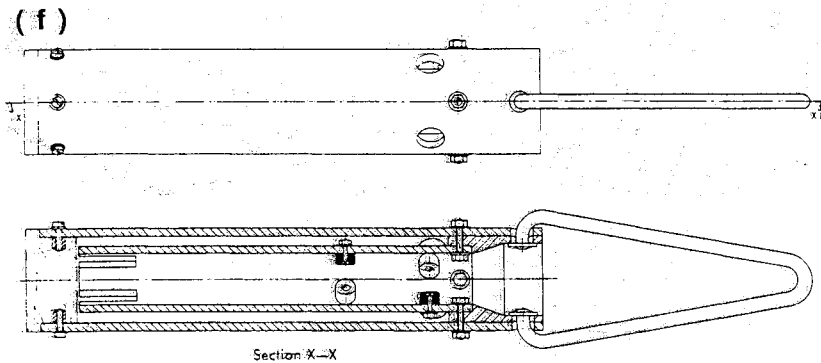
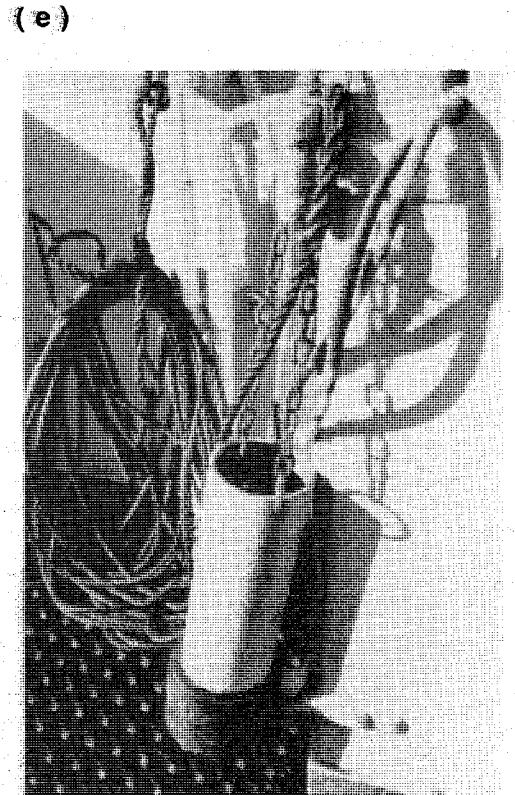
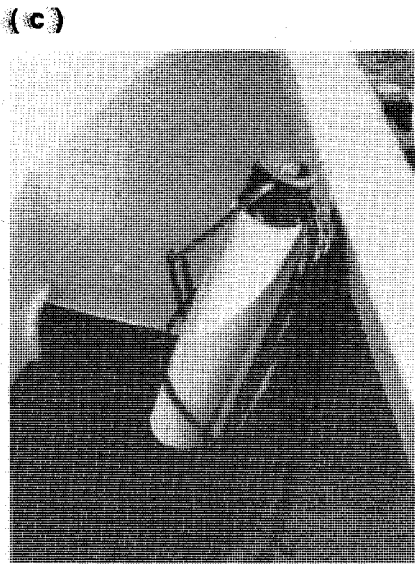
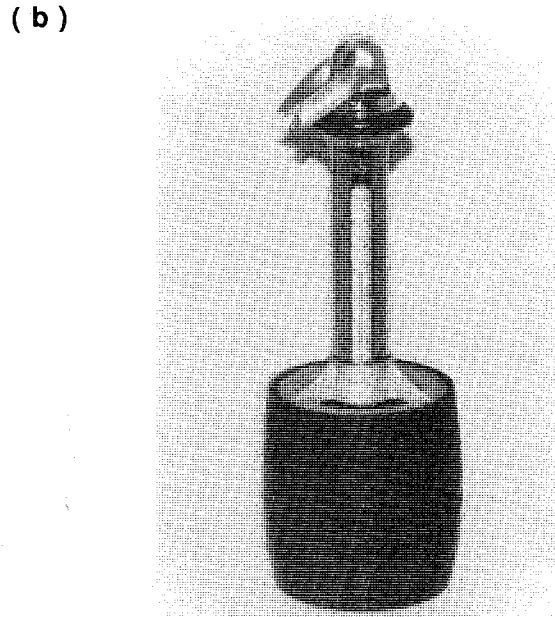
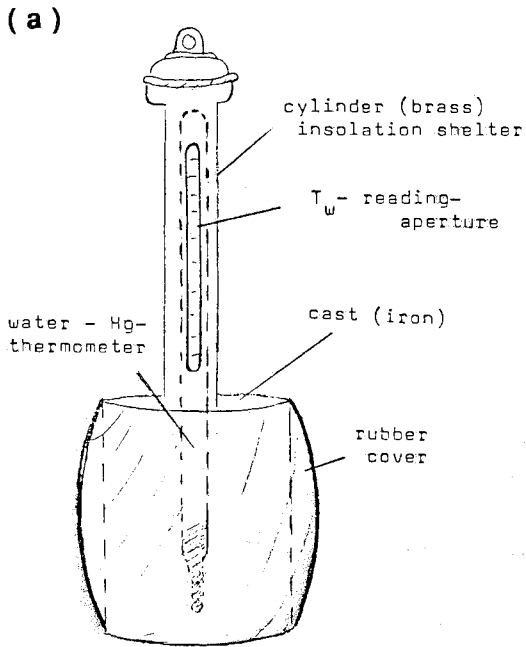

Figure 17 Types of sea temperature bucket designs used on the VSOP-NA ships. (a,b) France, Germany, (c - e) Netherlands, (f) U.K.(MO Mk.3A).

4.4.2 Height of Measurement

The barometers were normally situated on the Bridge or in the chart room, that is at a similar height (or one deck lower) to the temperature measurement and somewhat higher than for the VOS fleet as a whole (section 3.6). Instruments are typically at the 'height of eye' used for navigation.

4.4.3 Type of instrument

Figure 18 shows the Precision Aneroid Barometer used on the VSOP-NA ships.

Table 9. Measurement technique used for sea surface pressure observations for the VSOP-NA ships and for the VOS fleet as a whole.

Country	No. of Ships		Fraction of each fleet (%)					
			Digital Aneroid		Aneroid		Mercury	
	VSOP	VOS	VSOP	VOS	VSOP	VOS	VSOP	VOS
Canada	1	320	100	0	100	100	0	0
France	7	153	0	0	100	100	0	0
Germany	7	597	0	0	100	100	0	0
Netherlands	7	273	100	100	0	0	0	0
UK	10	464	100	>99	0	<<1	0	0
USA	13	745	0	<1	100	>99	0	<1
All ships	45	6527	40	9	60	89	0	2

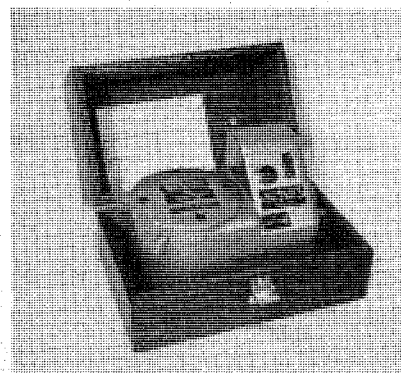
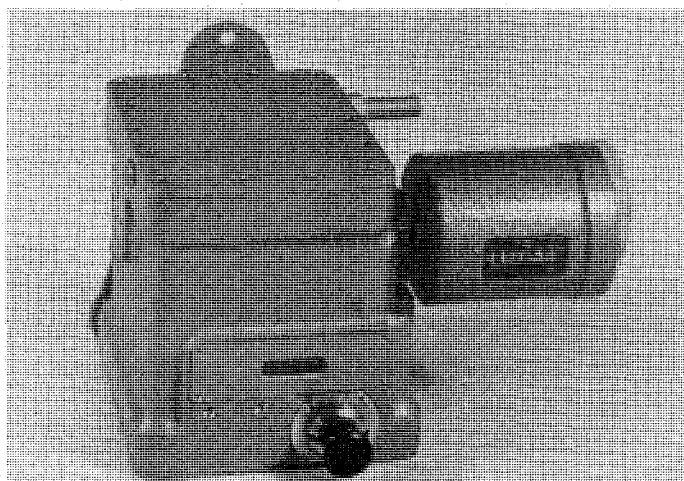

Figure 18 The Precision Aneroid Barometer (PAB) (MO, 1980).

4.5 Communications

The ease and reliability of communications between the ship and the shore will effect the reporting efficiency of the ship as a meteorological observing platform. All ocean going ships can be expected to carry MF, HF and VHF band radio communications equipment. The availability of satellite communications and of satellite navigation equipment on the VSOP-NA ships is shown in table 10. However this table only shows systems which were reported and it is likely that more of the VSOP-NA ships had these systems fitted.

Table 10. Satellite communications and navigation equipment on the VSOP-NA ships.

System	Number of ships
Inmarsat	12
Argos	1
Satellite Navigation (Navstar)	7
Satellite Navigation (GPS)	1

5. SUMMARY OF PART 1

Compared to the rest of the VOS fleet the VSOP-NA ships were different in several ways. The VSOP-NA ships were selected as having a good reporting record, because they regularly plied routes in the North Atlantic Ocean, and because they were willing to take part in the project. Once recruited, the VSOP-NA ships were documented as to ship details and instrumentation and asked to provide extra information with each observation.

The typical VSOP-NA ship was a container vessel of about 210m length which travelled at 17kts (8.5 m/s). It was loaded with cargo to about 10m to 20m above the main deck. Sea temperatures were measured by bucket or by engine intake or hull contact sensors at depths between 3m and 9m. The air temperature and humidity observations were taken at about 20m to 30m height above the sea, and the anemometer, if carried, was at about 30m to 35m. In these respects the VSOP-NA ships were biased toward greater length (and higher observing platforms) compared to the VOS fleet as a whole. The VSOP-NA ships reported between 20% and 40% of the maximum possible number of observations, the missing reports being partly due to in port periods or time spent outside the VSOP-NA area.

In general the mix of instrument types used on the VSOP-NA ships was similar to that for the VOS fleet as a whole. This was true for the fraction of visual and anemometer wind estimates (about 2/3 are visual), and for screen and psychrometer temperature and humidity measurements (roughly half and half with the VOS biased toward psychrometers and the VSOP-NA toward screens). For sea surface temperature 50% of the VSOP-NA used buckets compared to 30% of the VOS. There were also more VSOP-NA ships with hull contact sensors. The VSOP-NA ships used digital aneroid barometers to measure air pressure rather than the analogue aneroid barometers used by most of the VOS fleet, however this may really only indicate different ways of describing the same instrument for at least some cases.

Despite the various differences between the VSOP-NA ships and the VOS fleet as a whole, it is considered that the observations from the VSOP-NA ships will be of great value for investigating the accuracy of VOS reports. To aid that analysis, the full descriptions of the VSOP-NA ships are presented in Part 2.

6. ACKNOWLEDGEMENTS

We would like to acknowledge the following with out whose contribution this report could not have been assembled: the Owners, Masters, and Officers of the VSOP-NA ships; the Port Meteorological Officers, members of the VSOP-NA Management Committee, and staff of the Atmospheric Environment Service (Canada), Direction de la Météorologie Nationale (France), Deutscher Wetterdienst, Seewetteramt (Germany), Royal Netherlands Meteorological Institute (KNMI, Netherlands), Meteorological Office (UK), National Weather Service/NOAA (USA); and the World Weather Watch and World Climate Research Programme (WMO) and the Committee on Climate Changes and the Ocean (IOC/SCOR).

The report was prepared at the James Rennell Centre for Ocean Circulation as part of the UK contribution to the World Ocean Circulation Experiment.

7. REFERENCES

- Ive, D.S. (1987) A comparison of numbers of visually estimated and instrumentally measured wind data, Marine Technical Note No.2, Revised February 1987, (unpublished report available from Marine Advisory and Consultancy Service, Meteorological Office, Bracknell, U.K.) 43pp.
- Kent, E.C., Truscott, B., Hopkins, J., and Taylor, P. (1991) The accuracy of ship's meteorological observations - results of the VSOP-NA. Marine Meteorology and Related Oceanographic Activities, Report No. 26, WMO, Geneva.
- MO (1980) Handbook of Meteorological Instruments - 2nd Edition, Volume 1: Measurement of Atmospheric Pressure, London: Her Majesty's Stationary Office. pp. 11 - 20.
- MO (1981) Handbook of Meteorological Instruments - 2nd Edition, Volume 2: Measurement of Temperature, London: Her Majesty's Stationary Office. (Air temperature and Humidity, pp.11-12, Sea Surface temperature, pp.51 - 56)
- WMO (1970) The Beaufort scale of wind force (technical and operational aspects). Reports on Marine Science Affairs, No. 3, World Meteorological Organisation, Geneva, 22pp.
- WMO (1987) Final Report - Implementation Co-ordination meeting for the Ocean Observing System Development Programme Pilot Study on a high-quality Voluntary Observing Ships' subset, De Bilt, Netherlands, 21-23 September 1987 (unpublished report).
- WMO (1990) International List of Selected, Supplementary, and Auxiliary Ships, (1990 Edition - Magnetic tape version) WMO-47, World Meteorological Organisation, Geneva.
- Woodruff, S.D., Slutz, R.J., Jenne, R.L. & Steurer, P.M. (1987) A Comprehensive Ocean-Atmosphere Data Set, Bulletin of the American Meteorological Society, **68** (10), 1239-1250.

PART 2 THE SHIP CATALOGUE

1 Introduction

The following pages describe in detail each of the VSOP-NA ships. For each ship there is a set of ship drawings showing the position and surroundings of the sensors or measurement locations. The second page shows the ship size and the geographical positions of observations from that ship which are included in the VSOP-NA database. A table indicates the sensors carried and an assessment of the quality of the instrument exposure for relative winds from ahead (315° to 45°), the starboard beam (45° to 135°), astern (135° to 225°) and the port beam (225° to 315°). This exposure index (9 = good, 0 = bad) was assessed from the plans and photographs furnished by the PMO's using the following table. Three independent assessments were made by different people and a consensus used for the few cases of disagreement.

Exposure Index	Definition
0	Flow fully blocked adjacent to sensor (within 1m)
1	Flow fully blocked at medium distance (1m to 4m)
2	Flow fully blocked further away (4m to 10m)
3	Flow partially blocked near sensor (within 1m)
4	Flow partially blocked at medium distance (1m to 4m)
5	Flow partially blocked further away (4m to 10m)
6	Clear flow, long upwind fetch over ship (>30m)
7	Clear flow, upwind fetch over ship (10m to 30m)
8	Clear flow, upwind fetch over ship (1m to 10m)
9	Clear flow, short upwind fetch over ship (<1m)

IRVING FOREST - CALLSIGN VSBG8

Length: 129.4 m
 Breadth: 19.4 m
 Draft: 8.1 / 6.4
 Type: Cargo
 Recruiting Country: Canada
 Reference Level: 17±4 m asl

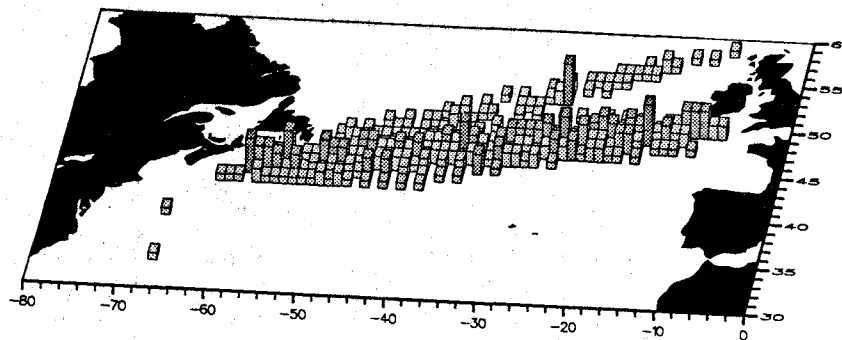
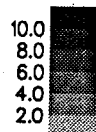

Instrument	Location	Instrument Type	Height ASL (m)	Height Above Deck (m)	Exposure				See Note
					315-045	045-135	135-225	225-315	
Anemometer	Radar mast Centreline	AES U2A	26		8	4	3	4	
Port Screen	Bridge deck	AES Marine Screen	19	1.5	5	1	8	9	1
Starboard Screen	Bridge deck		19	1.5	5	9	8	1	1
Psychrometer	Not fitted								
Barometer	Wheelhouse	Three fitted inc. PAB	19						
SST	Bucket	AES Rubber Sea Bucket							

Note 1 The screens are lashed to open metal rails with a solid metal bulwark to the front

The Irving Forest was lost at sea during VSOP-NA with no loss of life

The Irving Forest made 439 observations in the North Atlantic between 58°N and 33°N

IRVING FOREST - CALLSIGN VSBG8

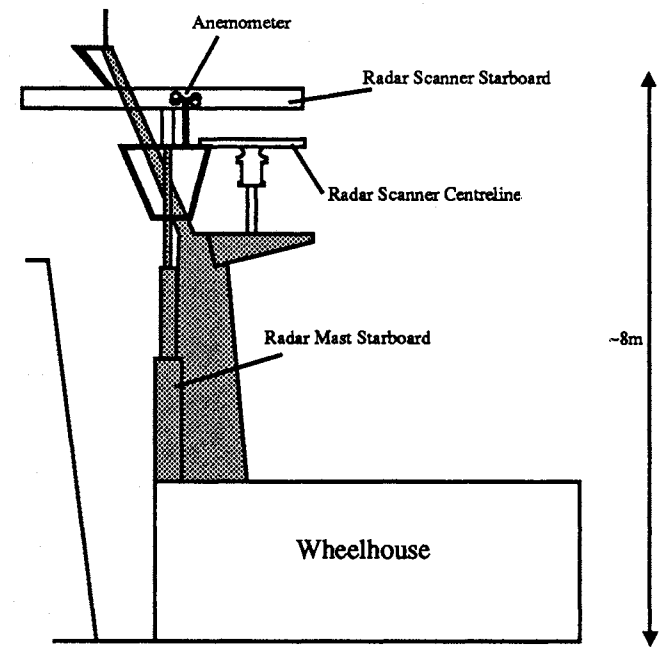
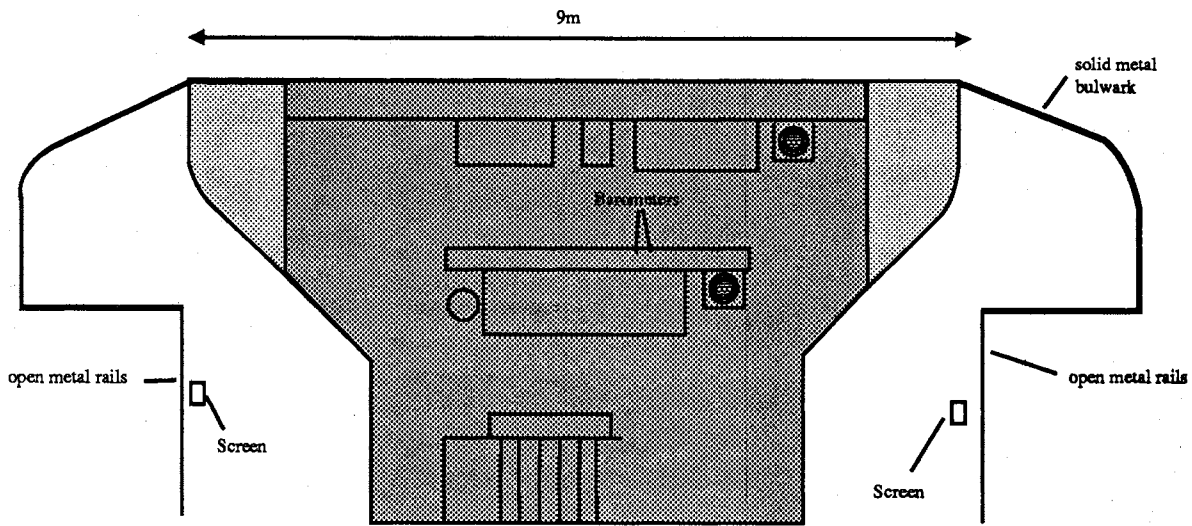
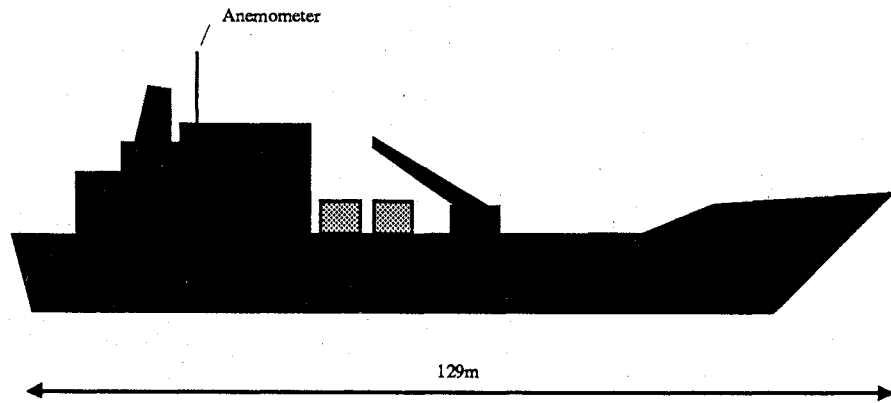

ARIANA - CALLSIGN DIDA

Length: 115 m
 Breadth: 19 m
 Draft: 7 m
 Type: Container
 Recruiting Country: France
 Reference Level: 19±5 m asl

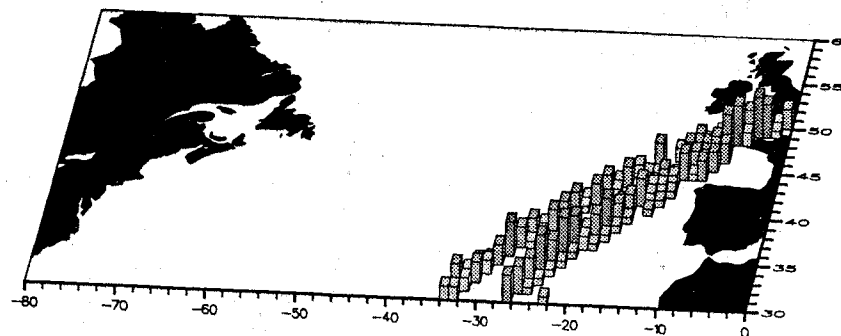
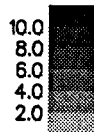

Instrument	Location	Instrument Type	Height ASL (m)	Height Above Deck (m)	Exposure				See Note
					315-045	045-135	135-225	225-315	
Anemometer	Mast on starboard forward corner of wheelhouse top	Pommar	27		9	7	7	8	1
Port Screen	Not fitted								
Starboard Screen	Rails on rear of wheelhouse top	Pommar	25		8	5	9	9	2
Psychrometer	Not fitted								
Aneroid Barometer	Wheelhouse	Naudet Compense	21						
SST	Engine room intake		-4						

- Note 1 The anemometer is on a mast about 2 m above the front edge of the wheelhouse top
 Note 2 Screen is situated 3 m from the front of the wheelhouse top. Wet and dry bulb temperatures are measured using platinum resistance thermometers

The Ariana has made 228 observations in the North Atlantic between 30°N and 51°N

ARIANA - CALLSIGN DIDA

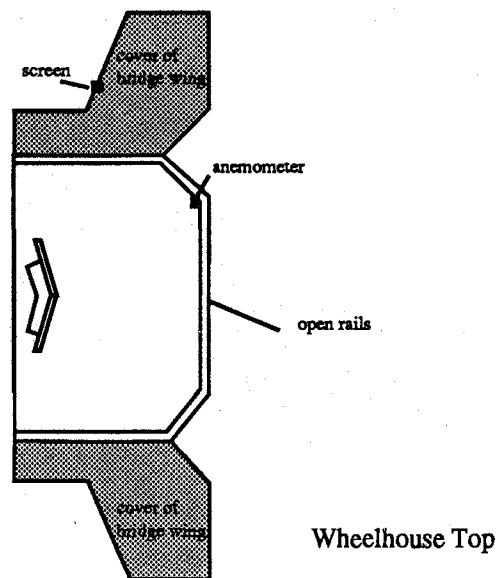
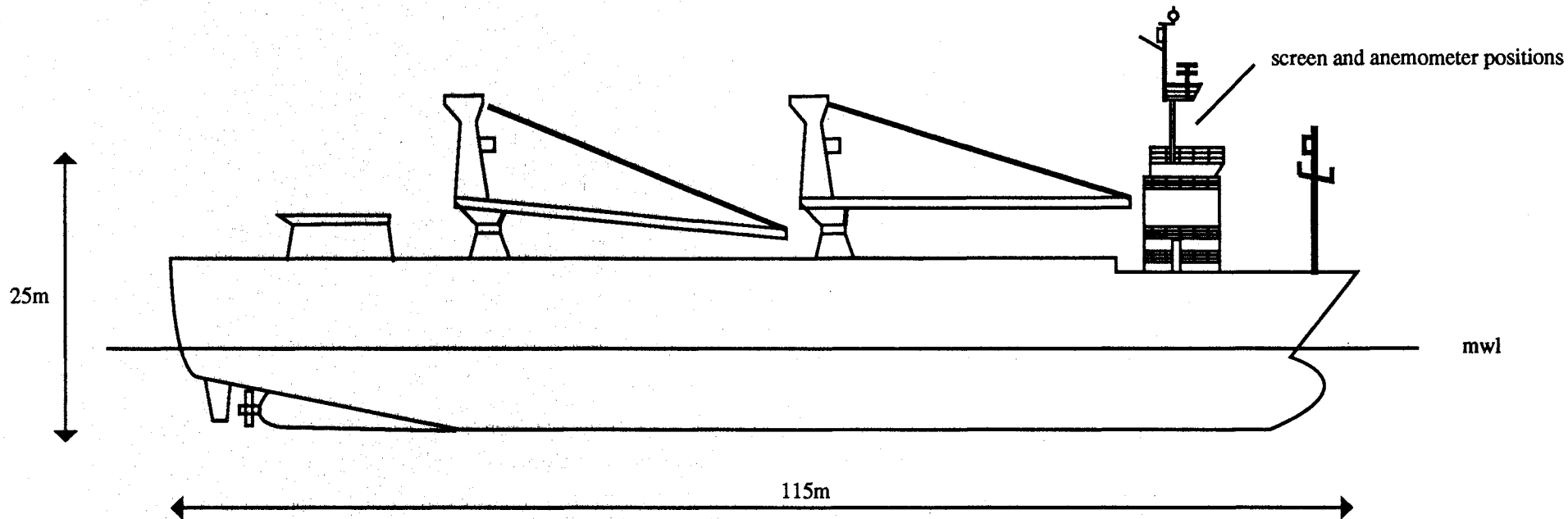

LIBREVILLE - CALLSIGN FNCZ

Length: 169.5 m
 Breadth: ~20 m
 Draft: 5 m
 Type: Container Ship
 Recruiting Country: France
 Reference Level: 22.5±1 m asl

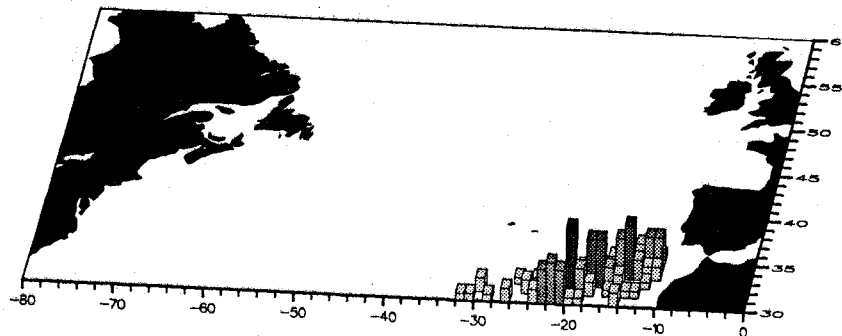
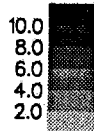

Instrument	Location	Instrument Type	Height ASL (m)	Height Above Deck (m)	Exposure				See Note
					315-045	045-135	135-225	225-315	
Anemometer	Handheld	Richard Pekly	21.5	~1.5	6	6	8	6	1
Screen	Not fitted								
Psychrometer	Used on port Bridge Wing	U01 4230	21.5	~1.5	4	1	8	8	2
Psychrometer	Used on starboard Bridge Wing	U01 4230	21.5	~1.5	4	8	8	1	2
Aneroid Barometer	Wheelhouse	Naudet	21.5						
SST	Engine room intake		-5.7						3
SST	Bucket	Maurer							3

- Note 1 Exposures have been estimated as no photographs were available. The handheld anemometer is used on the windward side of the Bridge Wing
- Note 2 The psychrometer is used on the windward side of the Bridge Wing. Exposures are estimated. Thermometers are mercury
- Note 3 The bucket is only used when sea water samples are taken, measurement is usually by collection thermometer

The Libreville has made 133 observations in the North Atlantic between 30°N and 38°N

LIBREVILLE - CALLSIGN FNCZ

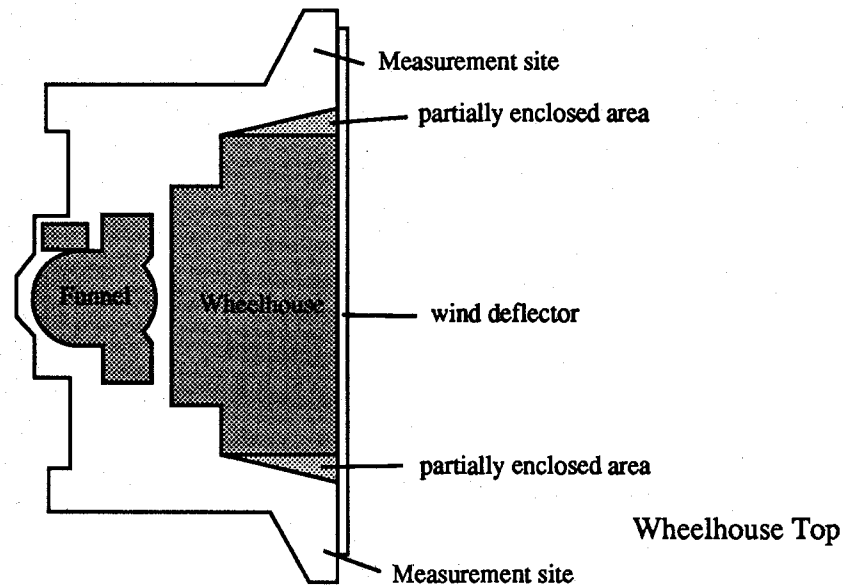
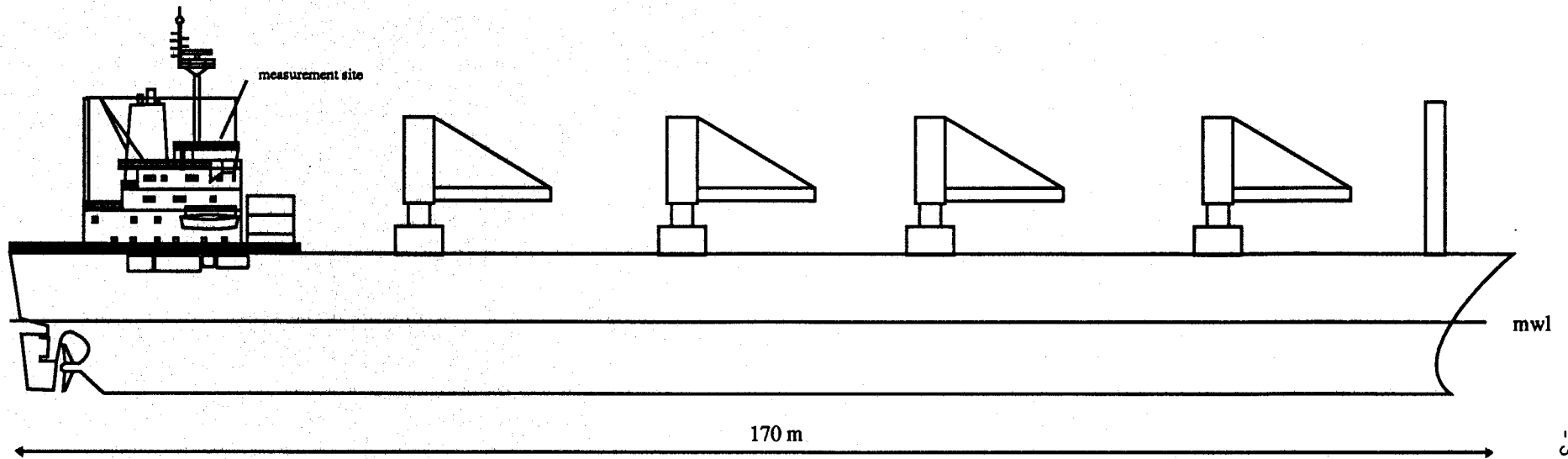

ATLANTIC CARTIER - CALLSIGN FNEF

Length: 293 m
 Breadth: 32 m
 Draft: 9.2 m
 Type: Ro-ro Container
 Recruiting Country: France
 Reference Level: 32±0.5 m asl

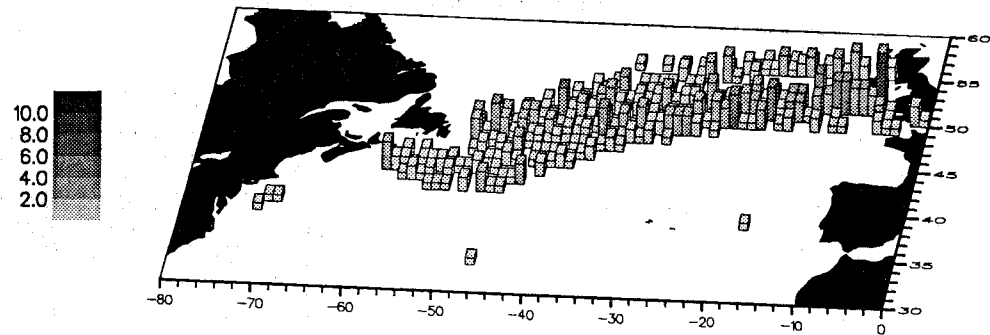

Instrument	Location	Instrument Type	Height ASL (m)	Height Above Deck (m)	Exposure				See Note
					315-045	045-135	135-225	225-315	
Anemometer	Main mast on Wheelhouse	Pommar / Walker	41	9.3	9	9	9	6	1
Port Screen	Wheelhouse Top	Pommar	33	2.2	8	7	8	9	2
Starboard Screen	Not fitted								
Psychrometer	Not fitted								
Aneroid Barometer	Wheelhouse	Pommar	~30						
SST	Engine room intake		?						

Note 1 The anemometer appears to be well exposed on the main mast but no photographs are available. The wind speed measurements must be affected by the large fetch over the containers

Note 2 Exposure ratings are estimated as no photographs available. Thermometers are electric resistance

The Atlantic Cartier has made 653 observations in the North Atlantic between 38°N and 56°N

ATLANTIC CARTIER - CALLSIGN FNEF

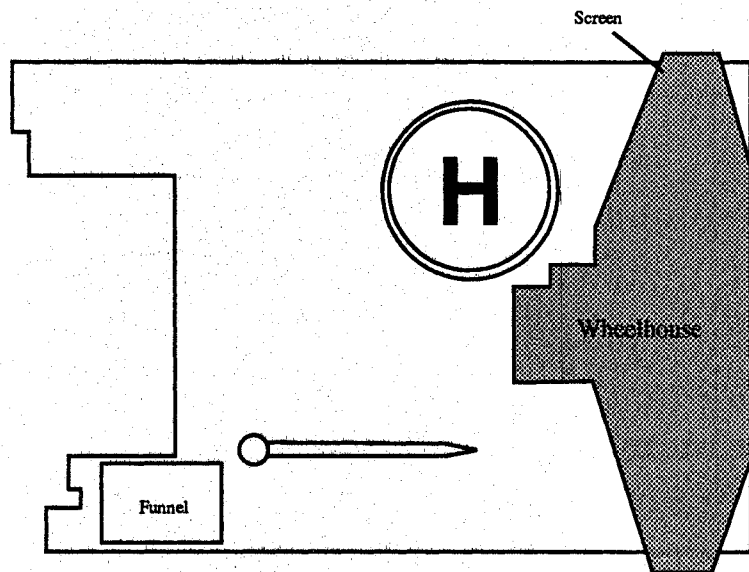
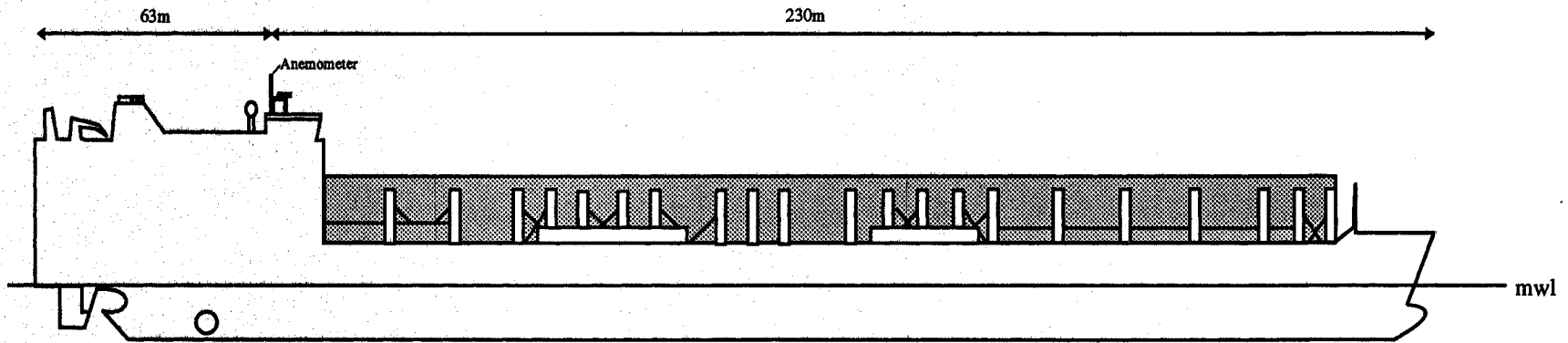

Plan of Wheelhouse Top

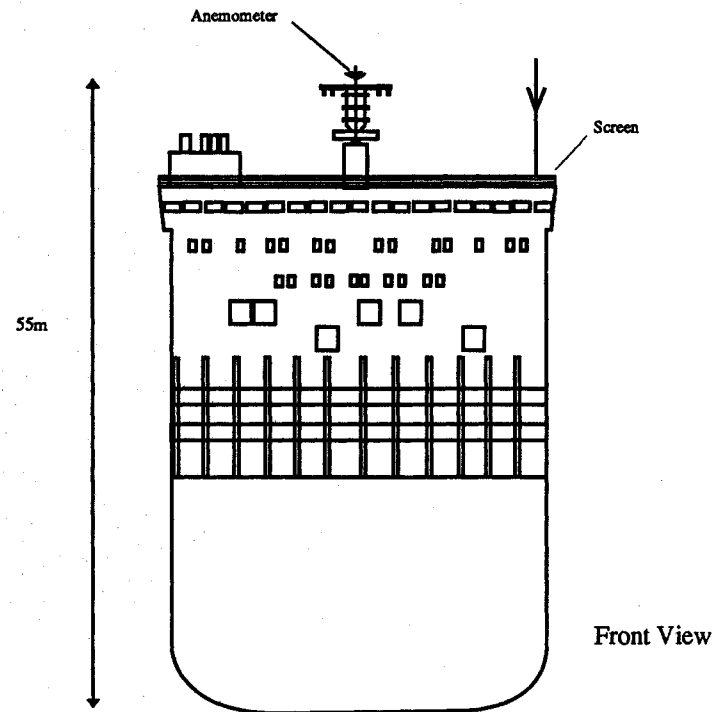

EDOUARD-LD - CALLSIGN FNFD

Length: 280.6
 Breadth: 41.6
 Draft: 11.2
 Type: Gas Tanker
 Recruiting Country: France
 Reference Level: 18±1 m asl

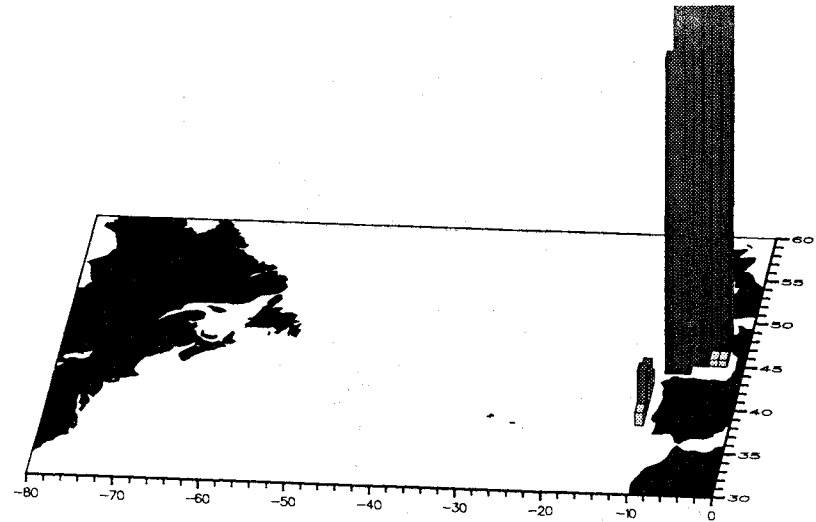
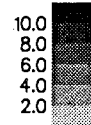

Instrument	Location	Instrument Type	Height ASL (m)	Height Above Deck (m)	Exposure				See Note
					315-045	045-135	135-225	225-315	
Anemometer	Mast on starboard forward corner of wheelhouse top	Tavid anemomograph	30		9	9	6	9	
Port Screen	Not fitted								
Starboard Screen	Upper Bridge		~26		8	9	7	7	1
Psychrometer	Not fitted								
Aneroid Barometer	Wheelhouse	Vibrochoc	~20						
SST	Engine room intake		-1						

Note 1 Screen is situated behind the anemometer mast, the forward exposure is therefore slightly blocked. The platinum resistance thermometers are remotely read from Bridge

The Edouard has made 1275 observations in the North Atlantic between 35°N and 47°N. Only 766 of these observations were included in the analysis at the James Rennel Centre as the remainder were too close to land to enable a suitable comparison with the model to be made.

EDOUARD-LD - CALLSIGN FNFD

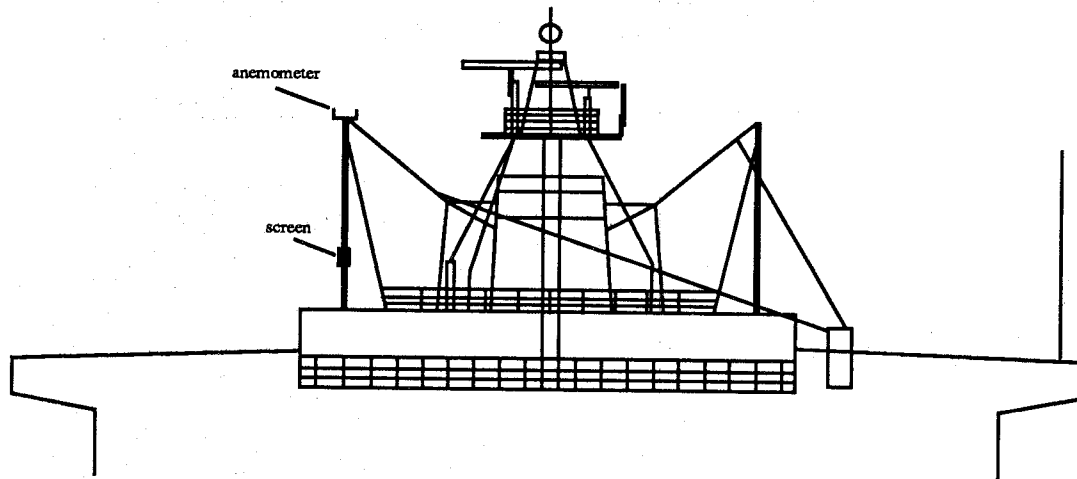
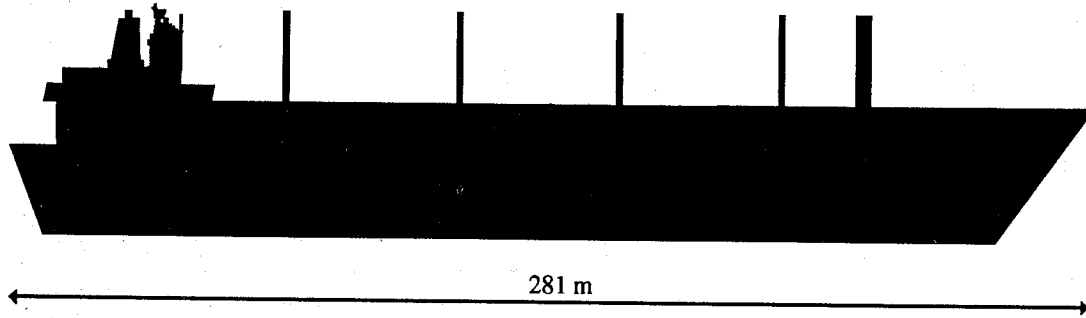

Wheelhouse - Front View

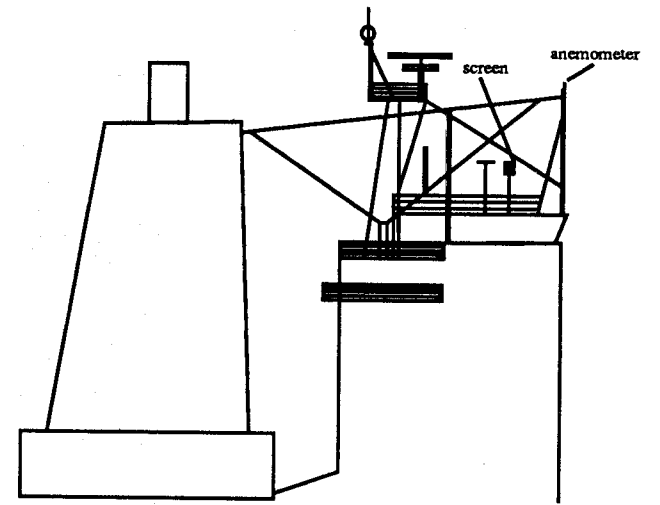

Wheelhouse - Starboard Side

LE CARABIE - CALLSIGN FNGM

Length: 204 m
 Breadth: 31 m
 Draft: 10 m
 Type: Container
 Recruiting Country: France
 Reference Level:

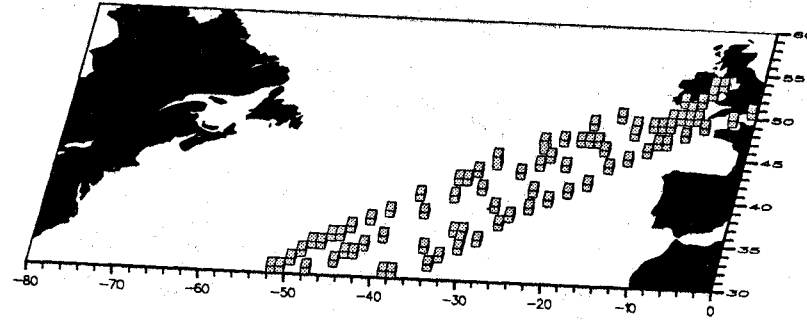
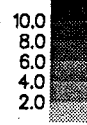

Instrument	Location	Instrument Type	Height ASL (m)	Height Above Deck (m)	Exposure				See Note
					315-045	045-135	135-225	225-315	
Anemometer	Handheld	Jules Richard	26.5-28.5	~1.5	4	4	4	4	1
Screen	Not fitted								
Psychrometer	Used on port Bridge Wing	Precis Mechanique	26.5-28.5	~1.5	4	1	8	8	2
Psychrometer	Used on starboard Bridge Wing	Precis Mechanique	26.5-28.5	~1.5	4	8	8	1	2
Aneroid Barometer	Wheelhouse		26.5-28.5						
SST	Bucket	STIL thermometer							3

Note 1 The handheld anemometer is used on the Bridge Wing

Note 2 Bridge Wings are enclosed by a solid metal bulwark, to the rear of the Bridge Wings are open metal rails. thermometers are mercury

Note 3 The bucket is lowered from the Bridge

The Carabie has made 81 observations in the North Atlantic between 30°N and 54°N

CARABIE - CALLSIGN FNGM

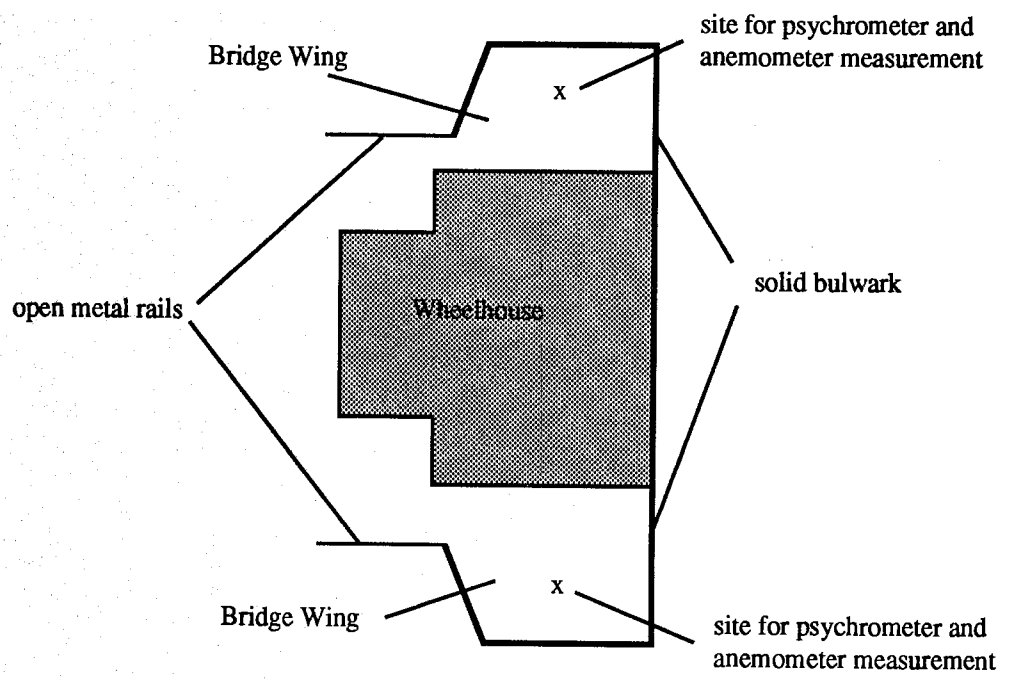
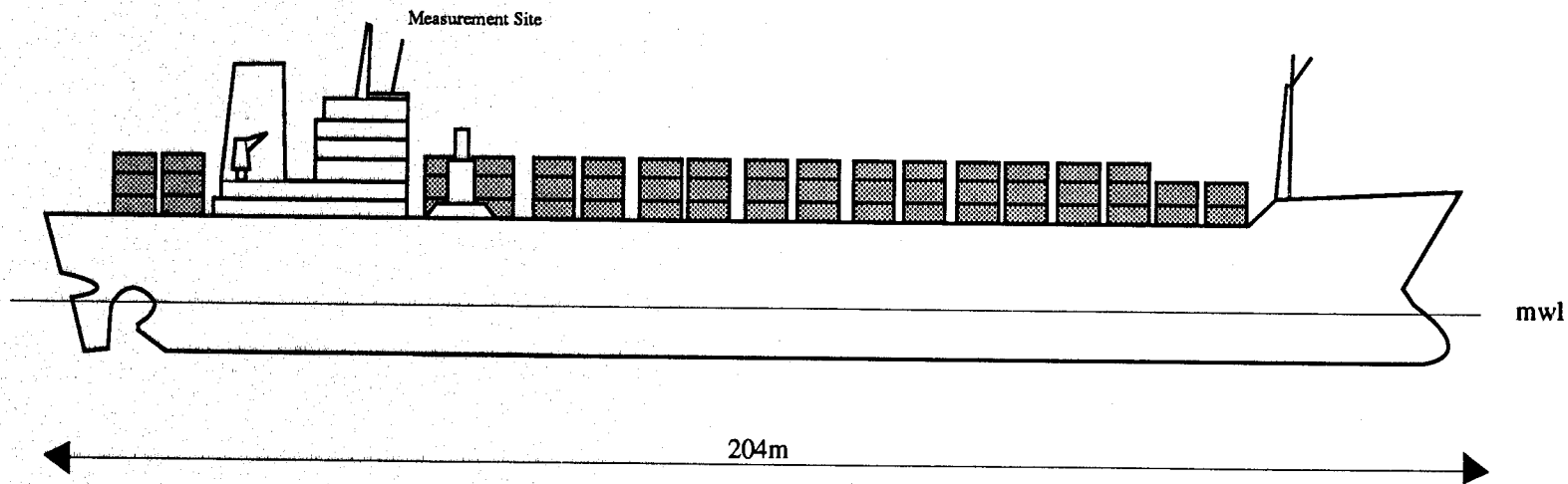

LA FAYETTE - CALLSIGN FNGS

Length: 204 m
 Breadth: 31 m
 Draft: 10 m
 Type: Container
 Recruiting Country: France
 Reference Level: 26±0.5 m asl

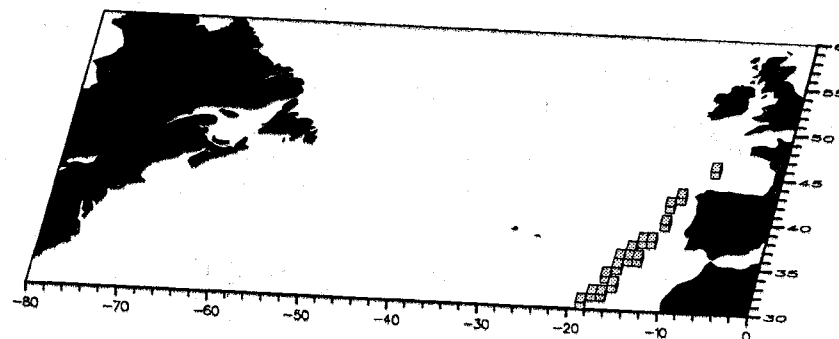
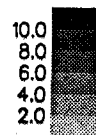

Instrument	Location	Instrument Type	Height ASL (m)	Height Above Deck (m)	Exposure				See Note
					315-045	045-135	135-225	225-315	
Anemometer	Handheld	Jules Richard No 64	29	~1.5	4	4	4	4	1
Screen	Not fitted								
Psychrometer	Used on port Bridge Wing	MNU04 Precis Mechanique	29	~1.5	4	1	8	8	2
Psychrometer	Used on starboard Bridge Wing	MNU04 Precis Mechanique	29	~1.5	4	8	8	1	2
Aneroid Barometer	Wheelhouse	Naudet Holosterique No 776	~29						
SST	Bucket	Metio							3

Note 1 The handheld anemometer is used on the Bridge Wing

Note 2 Bridge Wings are enclosed by a solid bulwark, to the rear of the Bridge Wings are open metal rails. Thermometers are mercury

Note 3 The bucket is lowered from the Bridge

La Fayette has made 16 observations in the North Atlantic

LA FAYETTE - CALLSIGN FNGS

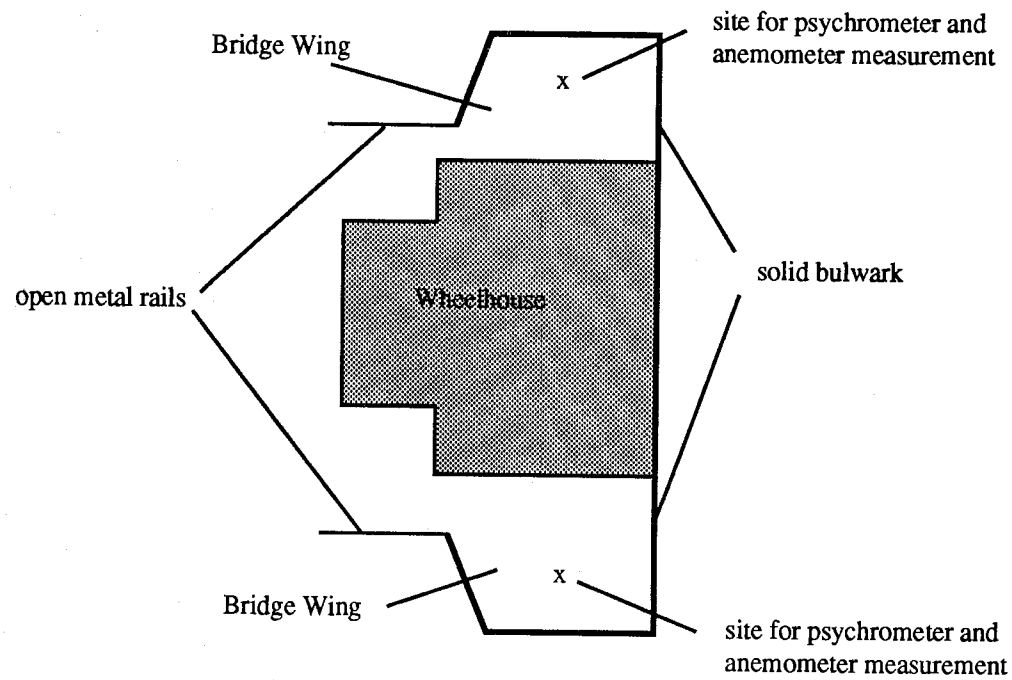
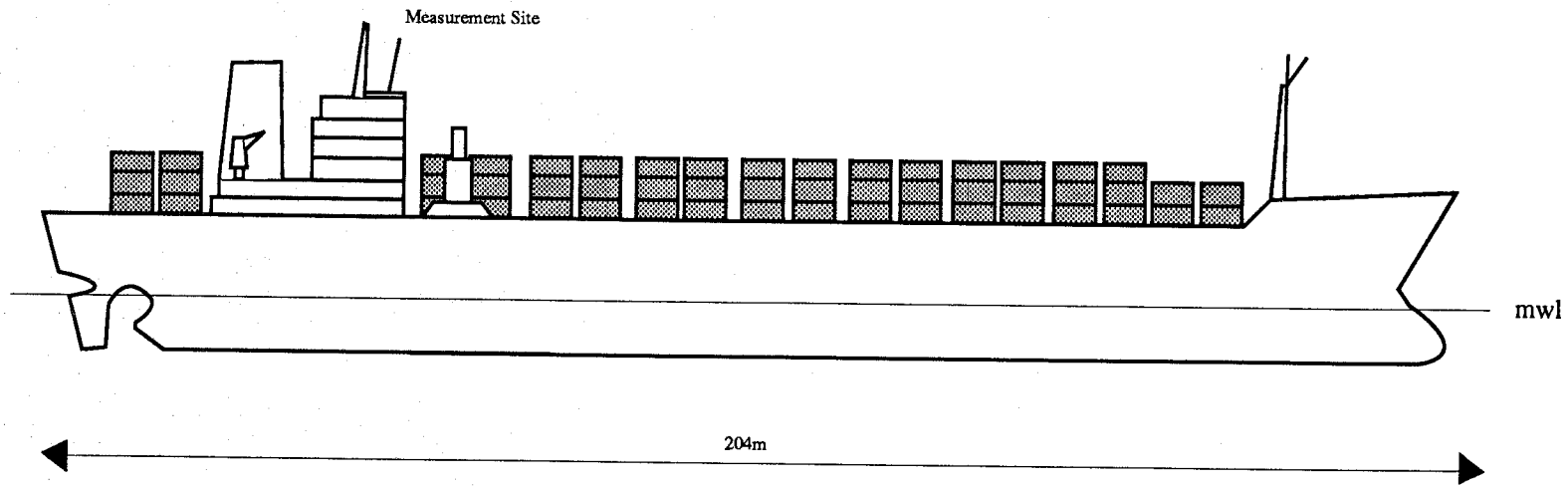

JEAN CHARCOT - CALLSIGN FNOY

Length: 75 m
 Breadth: 14 m
 Draft: 5 m
 Type: Research Vessel
 Recruiting Country: France
 Reference Level: 14±2 m asl

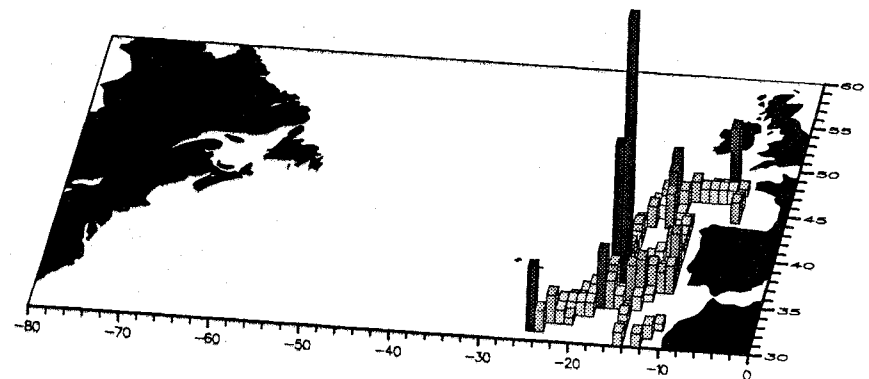
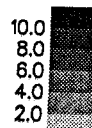

Instrument	Location	Instrument Type	Height ASL (m)	Height Above Deck (m)	Exposure				See Note
					315-045	045-135	135-225	225-315	
Anemometer	Port mainmast cross-tree	Pommar	21		9	6	9	9	1
Port Screen	Not fitted								1, 2
Starboard Screen	Mast on aft of wheelhouse top	Pommar	18		5	8	8	7	1, 2
Psychrometer	Not fitted								
Aneroid Barometer	Wheelhouse	Naudet Compense	17						
SST	Engine room intake		-3.5						

Note 1 Exposures have been estimated as no photographs were available
 Note 2 Thermometer is electric resistance

The Jean Charcot has made 271 observations in the North Atlantic between 30°N and 48°N

JEAN CHARCOT - CALLSIGN FNOY

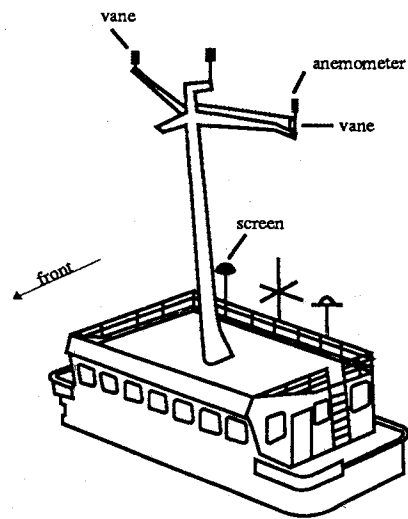
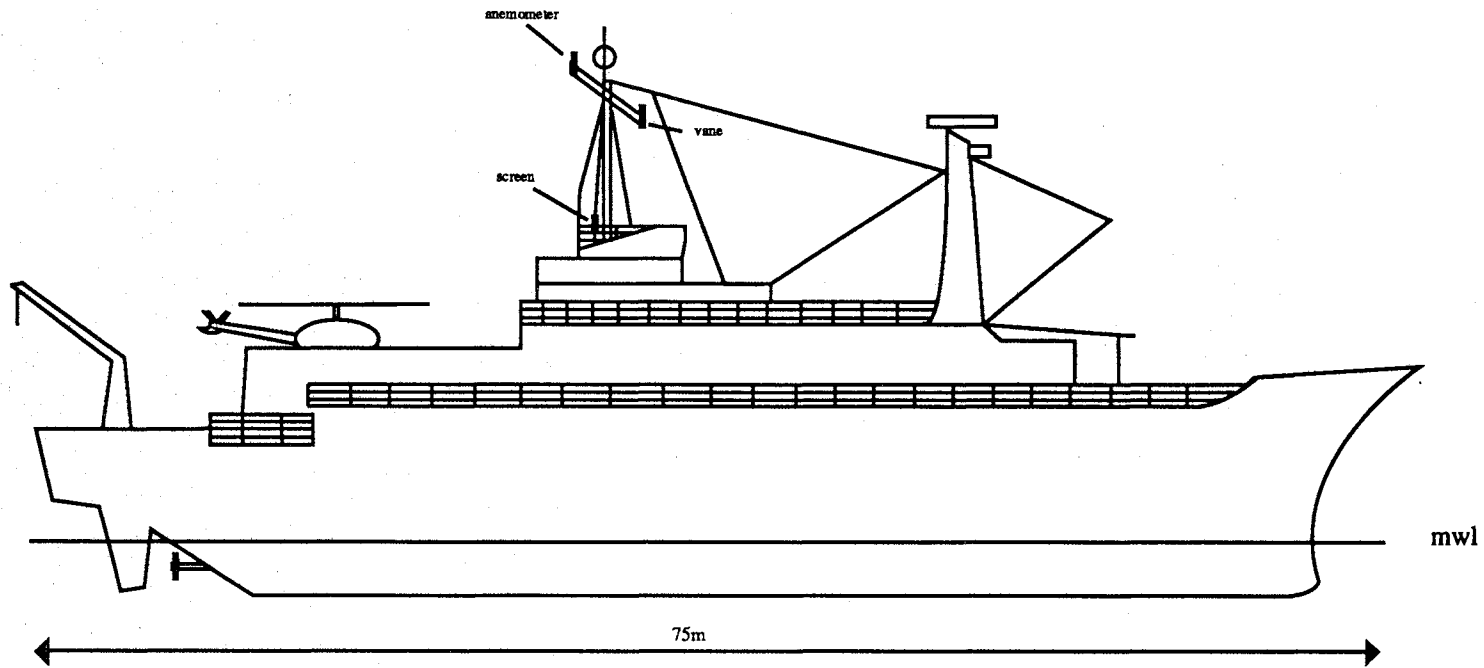

Wheelhouse Top

INDEPENDENT ENDEAVOR - CALLSIGN DDLN

Length: 136 m
 Breadth: 22 m
 Draft: 7 m
 Type: Container Ship
 Recruiting Country: Germany
 Reference Level: 0 m asl

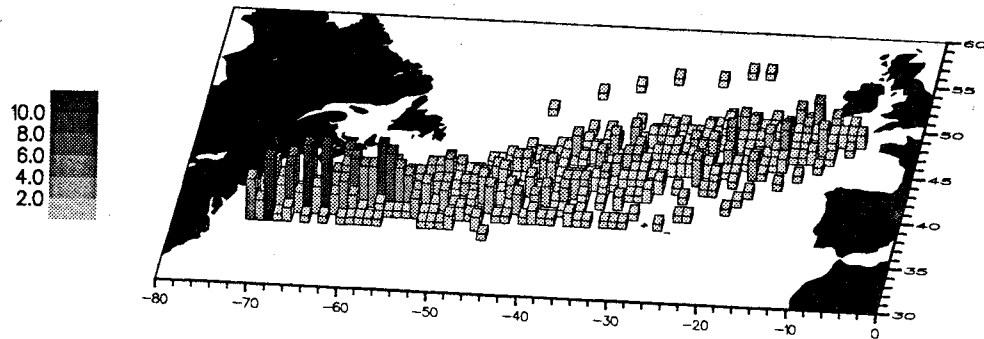

Instrument	Location	Instrument Type	Height ASL (m)	Height Above Deck (m)	Exposure				See Note
					315-045	045-135	135-225	225-315	
Anemometer	Not fitted								1
Screen	Not fitted								
Psychrometer	Used on port Bridge Wing	G K Walker Eigenbrodt	21	~1.5	4	1	8	8	2
Psychrometer	Used on starboard Bridge Wing	G K Walker Eigenbrodt	21	~1.5	4	8	8	1	2
Aneroid Barometer	Wheelhouse	Fuess type 15 PM	21						
SST	Bucket	See Figure 17							3
SST	Engine room intake		-6						3

- Note 1 Method of wind measurement is visual
 Note 2 The psychrometer is used on the windward side of the Bridge Wing which is surrounded by a solid metal bulwark with a wind deflector to the fore and open metal rails to the rear. Thermometers are mercury
 Note 3 Method of sea surface temperature measurement is reported with each observation

The Independent Endeavor has made 751 observations in the North Atlantic between 37°N and 56°N

INDEPENDENT ENDEAVOR - CALLSIGN DDLN

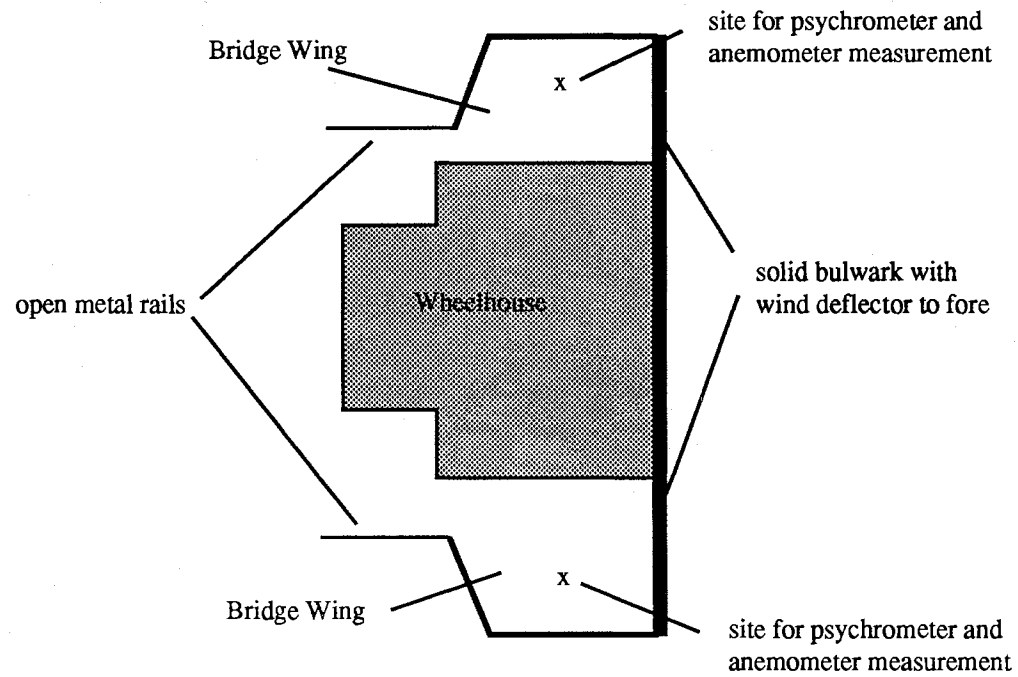
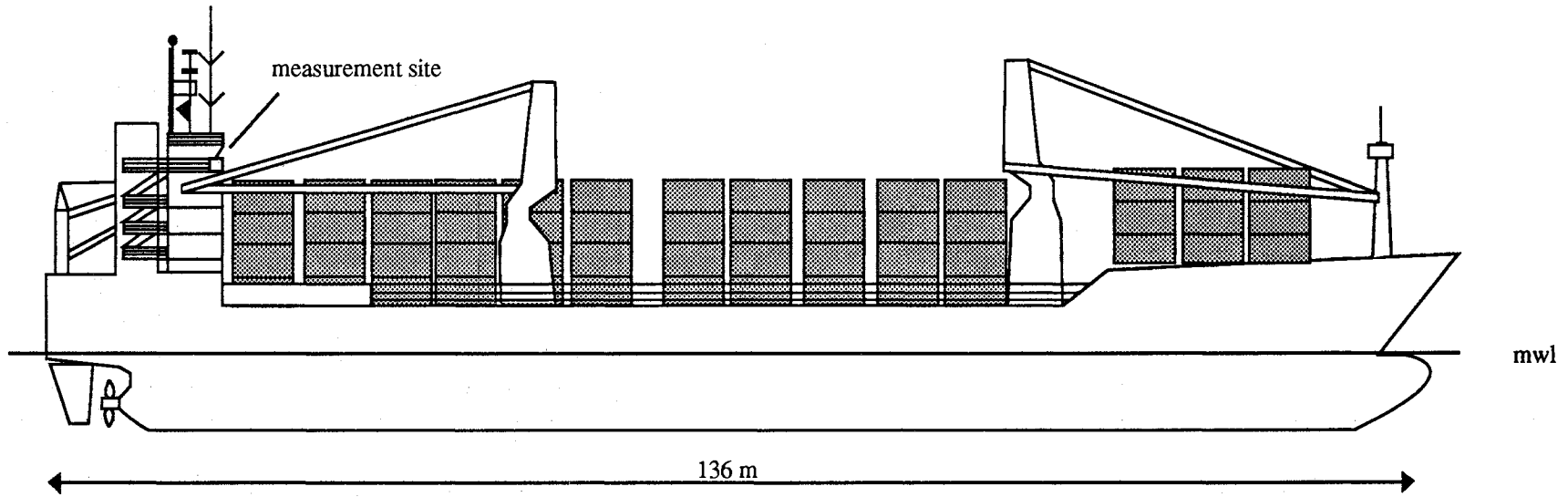

EUROTEXAS - CALLSIGN DDUC

Length: 186 m
 Breadth: 27 m
 Draft: 11 m
 Type: Container Ship
 Recruiting Country: Germany
 Reference Level: 0 m asl

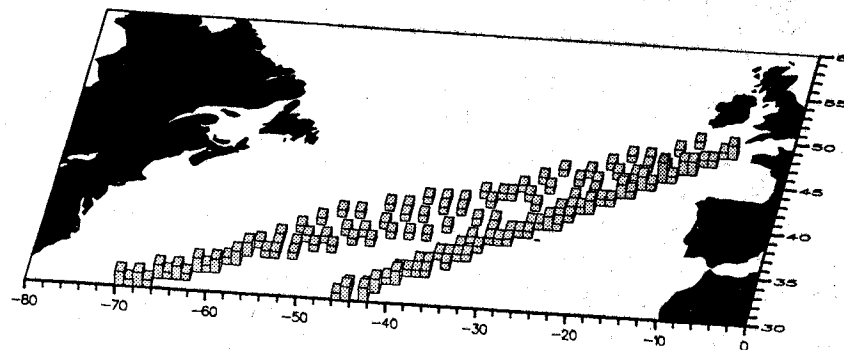
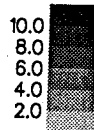

Instrument	Location	Instrument Type	Height ASL (m)	Height Above Deck (m)	Exposure				See Note
					315-045	045-135	135-225	225-315	
Anemometer	Not fitted								1
Screen	Not fitted								
Psychrometer	Used on port Bridge Wing	G K Walker Eigenbrodt	21	~1.5	4	1	8	8	2
Psychrometer	Used on starboard Bridge Wing	G K Walker Eigenbrodt	21	~1.5	4	8	8	1	2
Aneroid Barometer	Wheelhouse	Fuess type 15 PM	21						
SST	Bucket	See Figure 17							

Note 1 The method of wind measurement is visual

Note 2 The psychrometer is used on the windward side of the Bridge Wing, if the observation is made on the outboard end of the wing the forward exposure becomes 8. The Bridge Wing is surrounded by a solid metal bulwark and to the rear are open metal rails. Thermometers are mercury

The EuroTexas has made 148 observations in the North Atlantic between 30°N and 50°N

EURO TEXAS - CALLSIGN DDUC

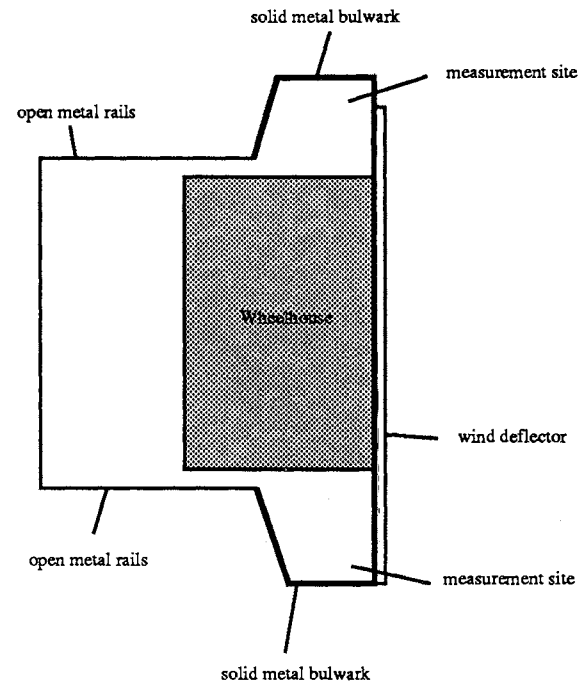
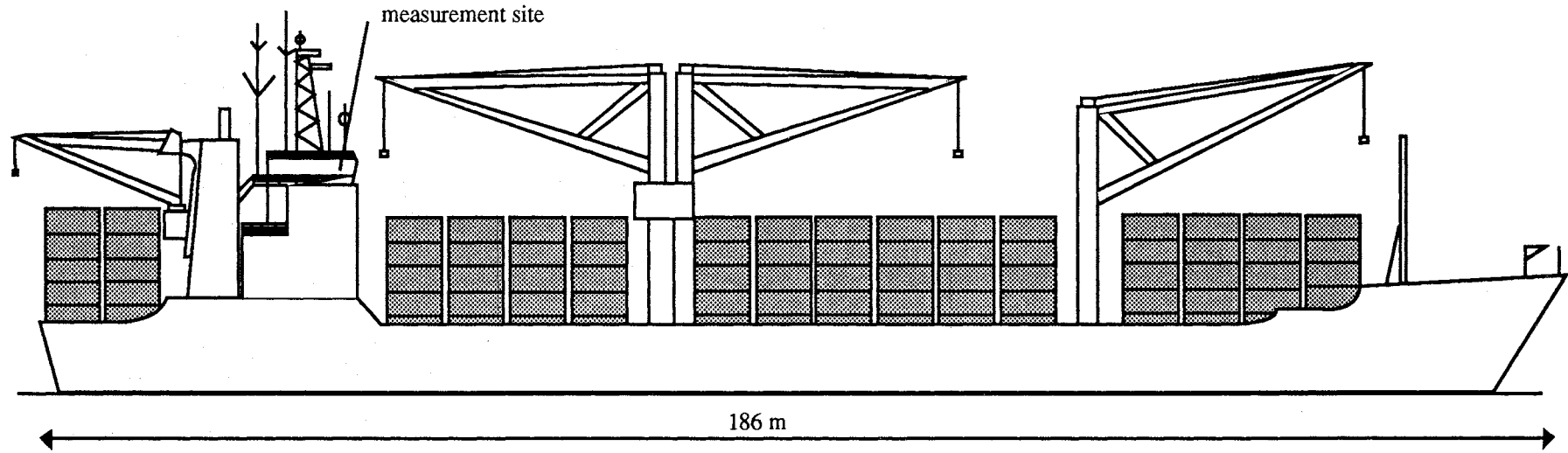

NURNBERG ATLANTIC - CALLSIGN DHNE

Length: 241 m
 Breadth: 32 m
 Draft: 9 m
 Type: Container Ship
 Recruiting Country: Germany
 Reference Level: 0 m asl

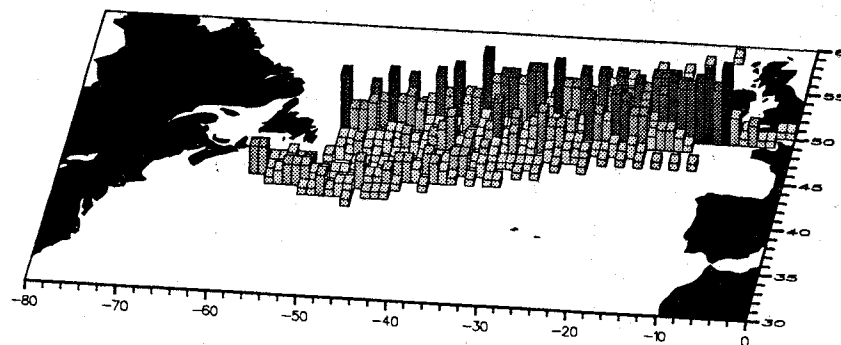
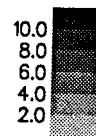

Instrument	Location	Instrument Type	Height ASL (m)	Height Above Deck (m)	Exposure				See Note
					315-045	045-135	135-225	225-315	
Anemometer	Not fitted								1
Screen	Not fitted								
Psychrometer	Used on port Bridge Wing	G K Walker Eigenbrodt	31	~1.5	4	1	8	8	2
Psychrometer	Used on starboard Bridge Wing	G K Walker Eigenbrodt	31	~1.5	4	8	8	1	2
Aneroid Barometer	Wheelhouse	Fuess type 15 PM	31						
SST	Bucket	See Figure 17							3
SST	Engine room intake		-8						3

Note 1 Method of wind measurement is visual

Note 2 The exposures of the observation sites have been estimated as no photographs were available. Thermometers are mercury

Note 3 Method of sea surface temperature measurement is reported with each observation

The Nurnberg Atlantic has made 981 observations in the North Atlantic between 40°N and 57°N

NURNBERG ATLANTIC - CALLSIGN DHNE

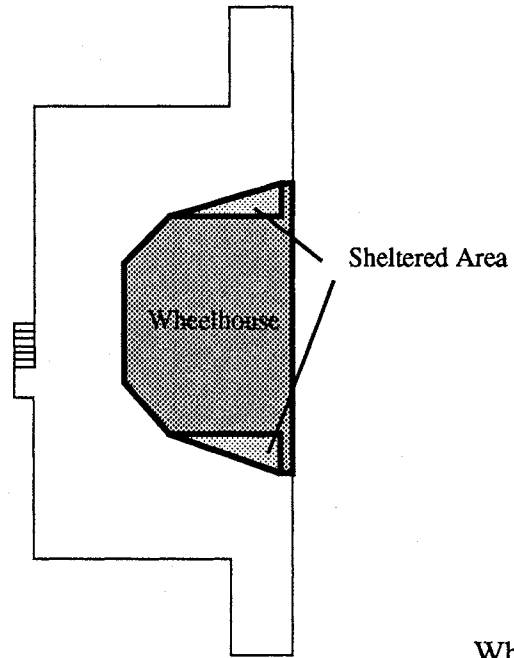
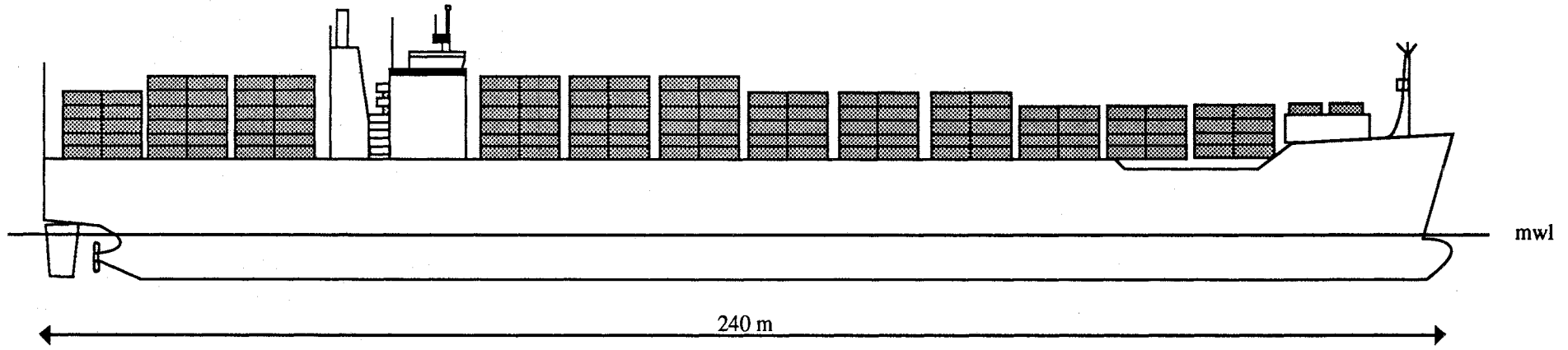

Wheelhouse Top

ALEMANIA EXPRESS - CALLSIGN DHRG

Length: 204 m
 Breadth: 31 m
 Draft: 10 m
 Type: Container Ship
 Recruiting Country: Germany
 Reference Level: 0 m asl

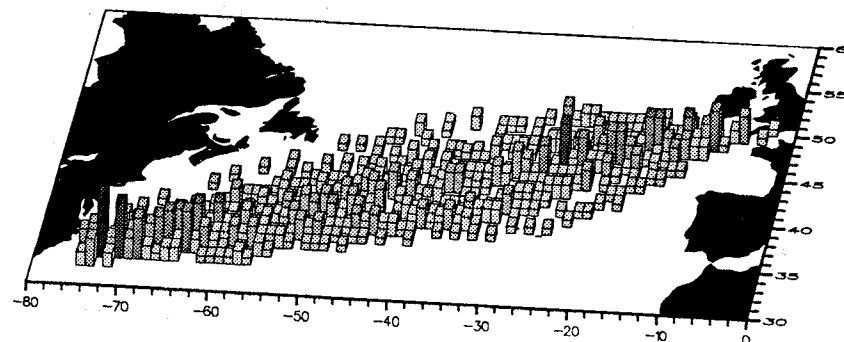
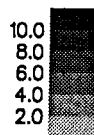

Instrument	Location	Instrument Type	Height ASL (m)	Height Above Deck (m)	Exposure				See Note
					315-045	045-135	135-225	225-315	
Anemometer	Not fitted								1
Screen	Not fitted								
Psychrometer	Used on port Bridge Wing	G K Walker Eigenbrodt	25	~1.5	4	1	8	8	2
Psychrometer	Used on starboard Bridge Wing	G K Walker Eigenbrodt	25	~1.5	4	8	8	1	2
Aneroid Barometer	Wheelhouse	Fuess type 15 PM	25						
SST	Engine room intake		-8						
SST	Bucket	See Figure 17							

Note 1 Method of wind measurement is visual

Note 2 The psychrometer is used on the windward side of the Bridge Wing. The Bridge Wing is surrounded by a solid metal rail with a wind deflector to the front. To the rear are open metal rails. Thermometers are mercury

The Alemania Express has made 772 observations in the North Atlantic between 30°N and 51°N

ALEMANIA EXPRESS - CALLSIGN DHRG

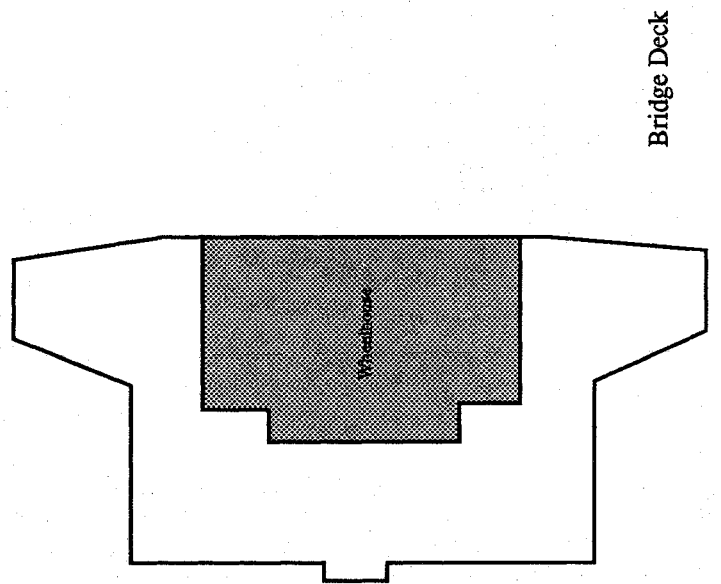
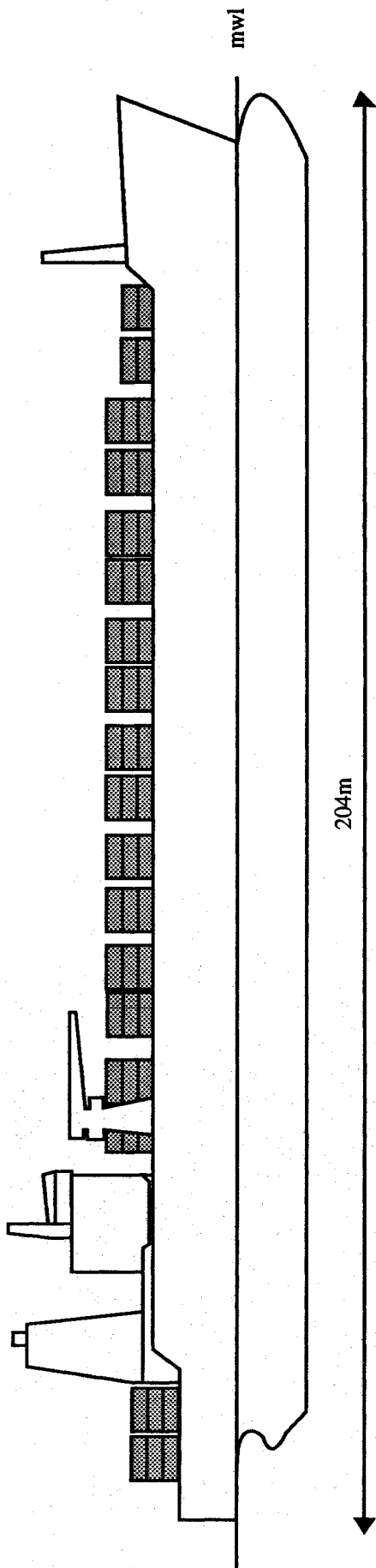

AMERICA EXPRESS - CALLSIGN DIMC

Length: 204 m
 Breadth: 31 m
 Draft: 10 m
 Type: Container Ship
 Recruiting Country: Germany
 Reference Level: 0 m asl

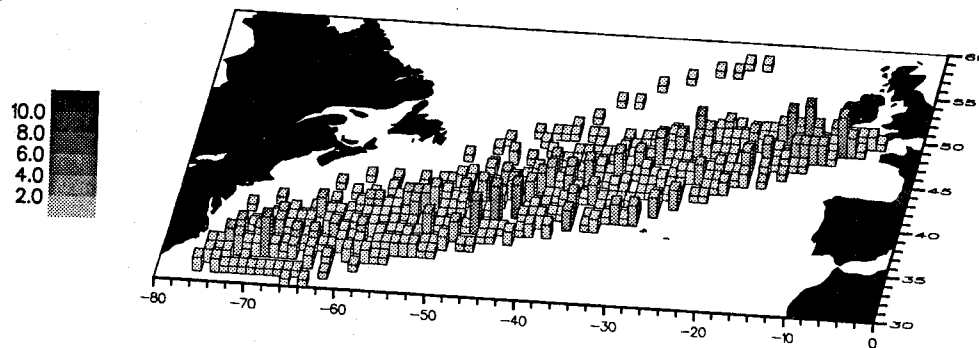

Instrument	Location	Instrument Type	Height ASL (m)	Height Above Deck (m)	Exposure				See Note
					315-045	045-135	135-225	225-315	
Anemometer	Not fitted								1
Screen	Not fitted								
Psychrometer	Used on port Bridge Wing	G K Walker Eigenbrodt	25	~1.5	4	1	8	8	2
Psychrometer	Used on starboard Bridge Wing	G K Walker Eigenbrodt	25	~1.5	4	8	8	1	2
Aneroid Barometer	Wheelhouse	Fuess type 15 PM	25						
SST	Engine room intake	See Figure 17	-8						
SST	Bucket	See Figure 17							

Note 1 Method of wind measurement is visual

Note 2 The psychrometer is used on the windward side of the Bridge Wing. The Bridge Wing is surrounded by a solid metal rail with a wind deflector to the front. To the rear are open metal rails. Thermometers are mercury

The America Express has made 721 observations in the North Atlantic between 30°N and 51°N

AMERICA EXPRESS - CALLSIGN DIMC

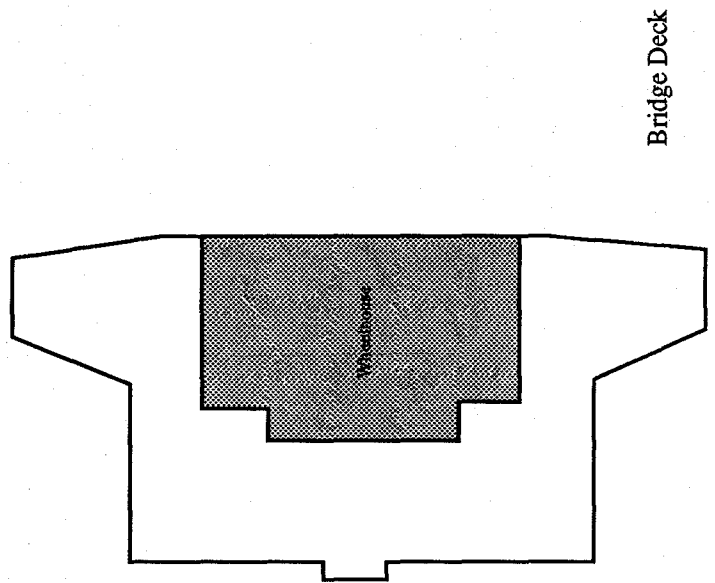
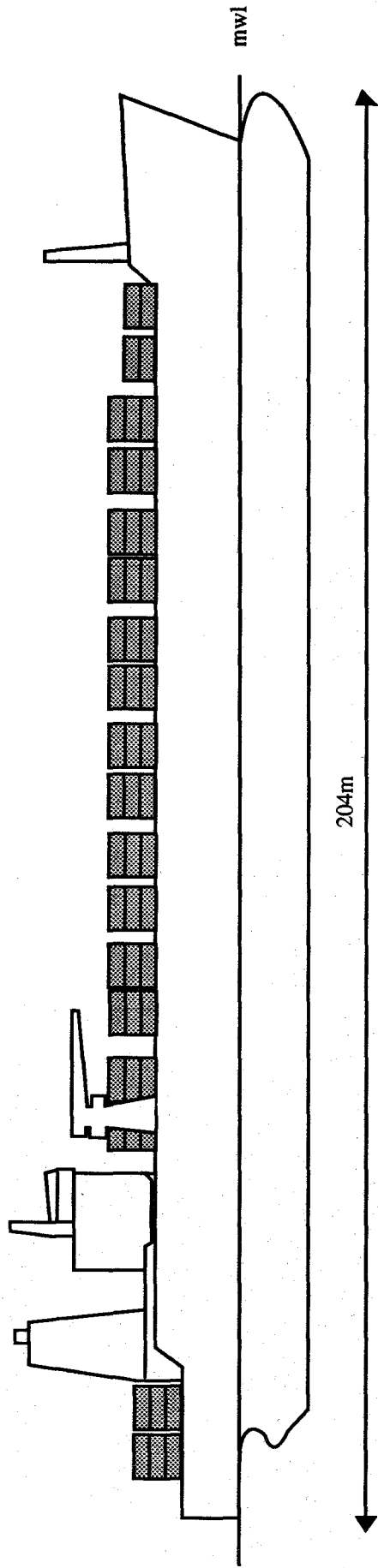

INDEPENDENT CONCEPT - CALLSIGN DNBR

Length: 118 m
 Breadth: 20 m
 Draft: 7.5 m
 Type: Container Ship
 Recruiting Country: Germany
 Reference Level: 0 m asl

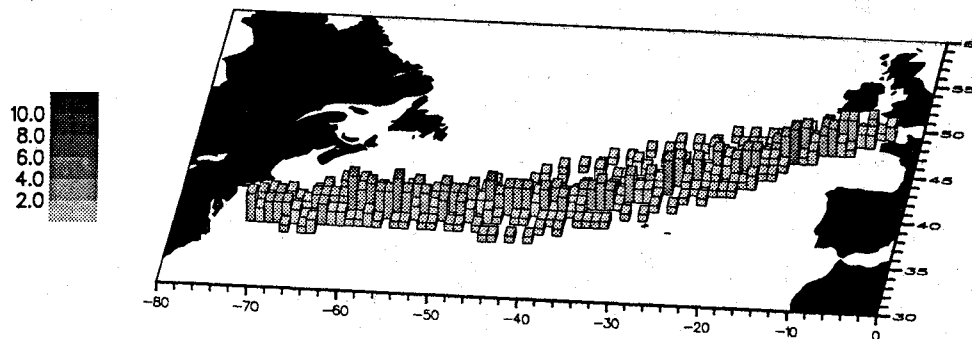

Instrument	Location	Instrument Type	Height ASL (m)	Height Above Deck (m)	Exposure				See Note
					315-045	045-135	135-225	225-315	
Anemometer	Not fitted								1
Screen	Not fitted								
Psychrometer	Used on port Bridge Wing	G K Walker Eigenbrodt	19	~1.5	8	1	8	8	2
Psychrometer	Used on starboard Bridge Wing	G K Walker Eigenbrodt	19	~1.5	8	8	8	1	2
Aneroid Barometer	Wheelhouse	Fuess type 15 PM	19						
SST	Bucket	See Figure 17							

Note 1 Method of wind measurement is visual

Note 2 The psychrometer is used on the windward side of the Bridge Wing. The Bridge Wing is surrounded by a solid metal bulwark, to the rear of the Bridge Wing are open metal rails. Thermometers are mercury

The Independent Concept has made 459 observations in the North Atlantic between 36°N and 50°N

INDEPENDENT CONCEPT - CALLSIGN DNBR

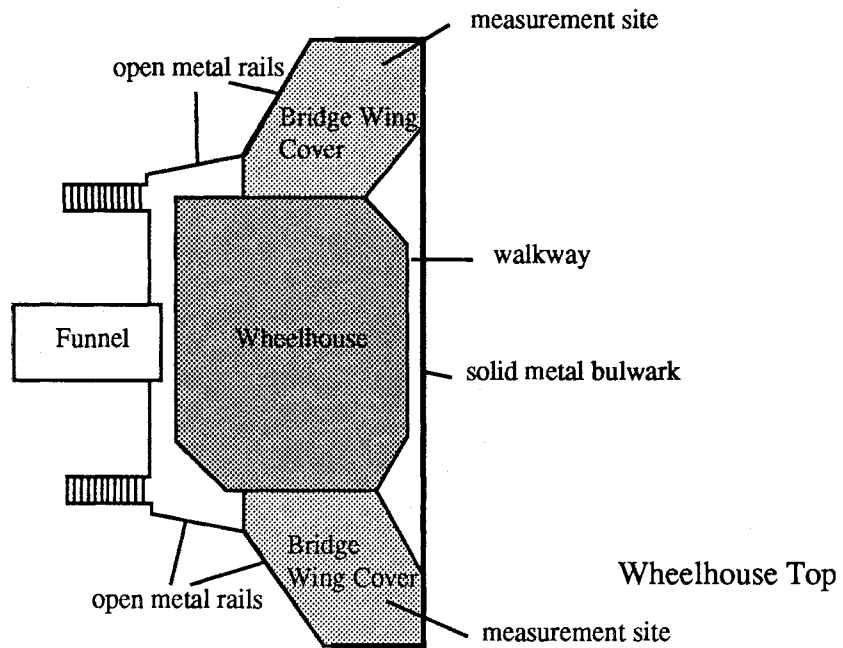
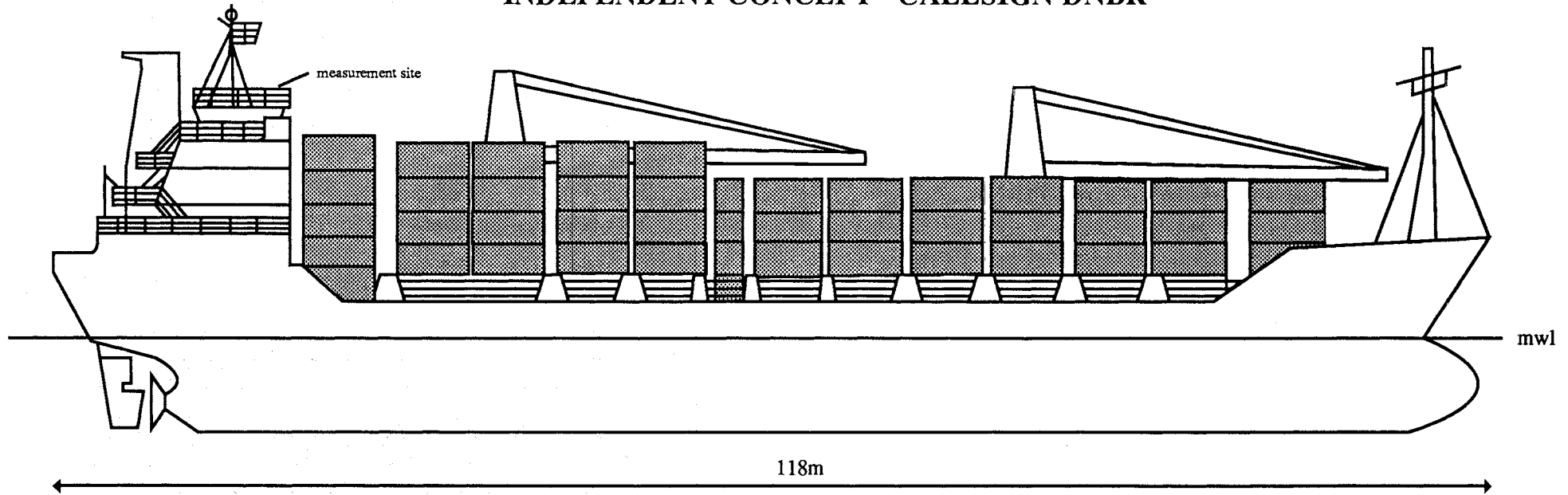

INDEPENDENT PURSUIT - CALLSIGN DNJR

Length: 133 m
 Breadth: 22 m
 Draft: 7.5 m
 Type: Container Ship
 Recruiting Country: Germany
 Reference Level: 0 m asl

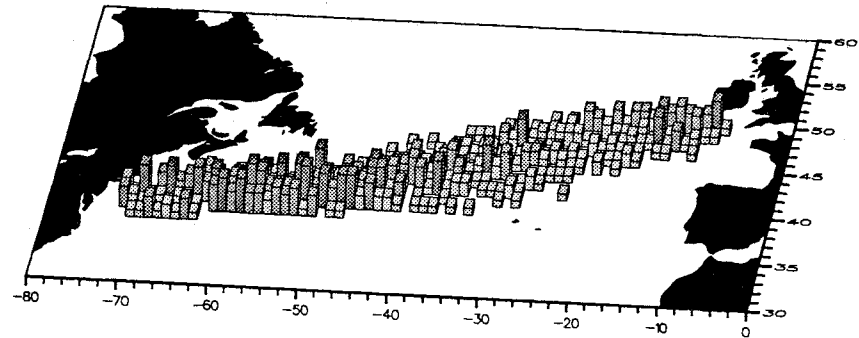
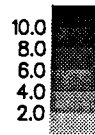

Instrument	Location	Instrument Type	Height ASL (m)	Height Above Deck (m)	Exposure				See Note
					315-045	045-135	135-225	225-315	
Anemometer	Not fitted								1
Screen	Not fitted								
Psychrometer	Used on port Bridge Wing	G K Walker Eigenbrodt	22	~1.5	8	1	8	8	2
Psychrometer	Used on starboard Bridge Wing	G K Walker Eigenbrodt	22	~1.5	8	8	8	1	2
Aneroid Barometer	Wheelhouse	Fuess type 15 PM	22						
SST	Bucket	See Figure 17							

Note 1 Method of wind measurement is visual

Note 2 The psychrometer is used on the windward side of the Bridge Wing. The Bridge Wing is surrounded by a solid metal bulwark, to the rear of the Bridge Wing are open metal rails. Thermometers are mercury

The Independent Pursuit has made 599 observations in the North Atlantic between 37°N and 50°N

INDEPENDENT PURSUIT - CALLSIGN DNJR

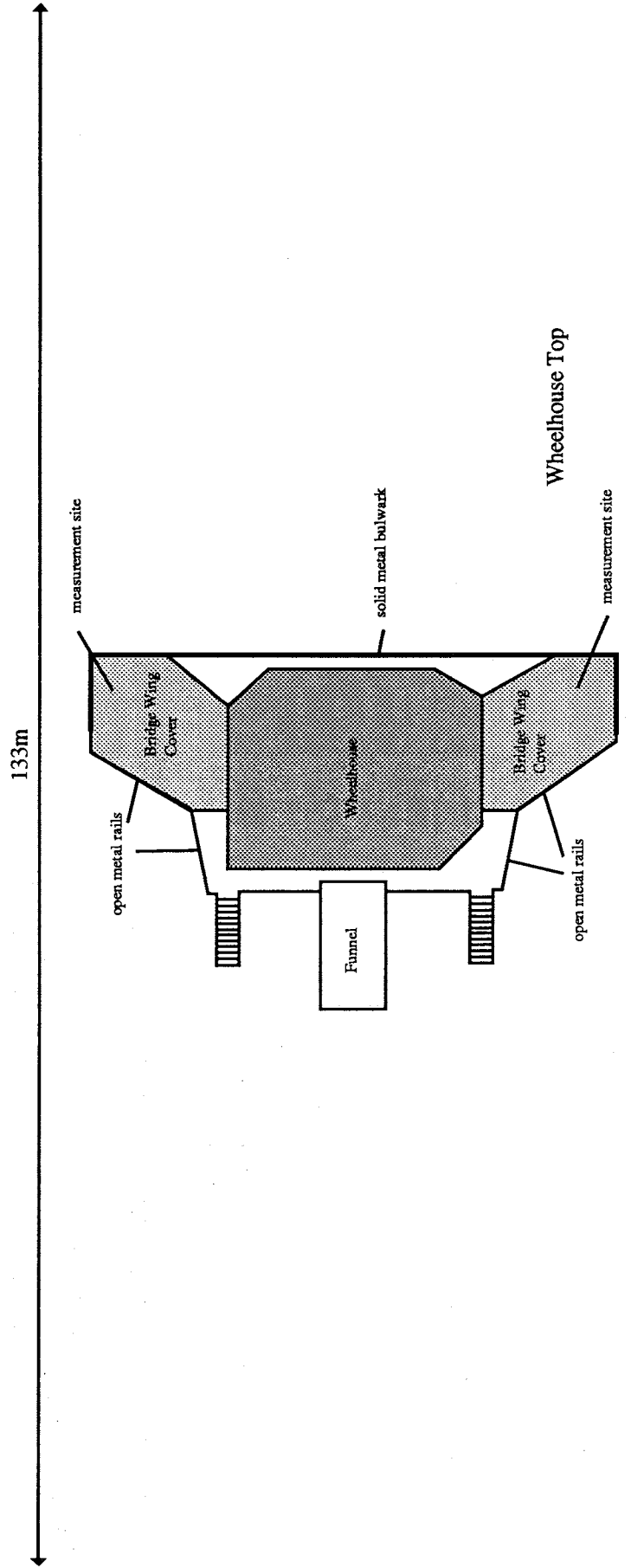
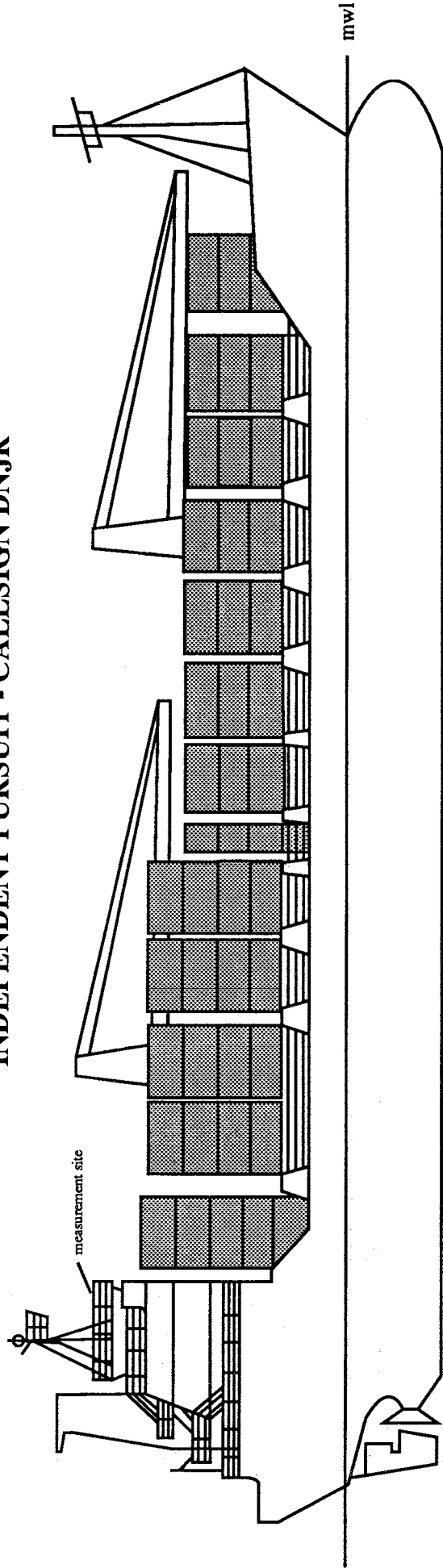

AEL AMERICA - CALLSIGN PCEL

Length: 156.9
 Breadth: 22.9
 Draft: 11.2
 Type: Container
 Recruiting Country: Netherlands
 Reference Level: 3±1 m asl

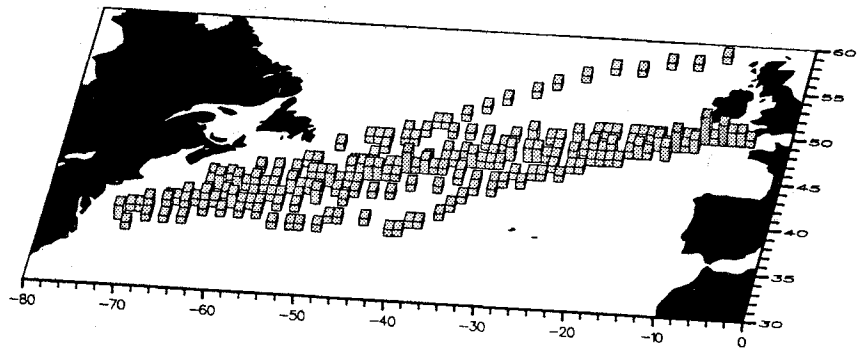
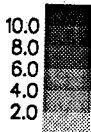

Instrument	Location	Instrument Type	Height ASL (m)	Height Above Deck (m)	Exposure				See Note
					315-045	045-135	135-225	225-315	
Anemometer	Not fitted								1
Screen	Not fitted								
Psychrometer	Used on port Bridge Wing	KNMI	21	~1.5	4	1	8	8	2
Psychrometer	Used on starboard Bridge Wing	KNMI	21	~1.5	4	8	8	1	2
Barometer	Wheelhouse	PAB	21						
SST	Bucket								3

- Note 1 The method of wind measurement is visual
- Note 2 Exposures are estimated as no photographs or plans of the ship were available
- Note 3 Bucket is lowered from the Bridge Wing

The AEL America has made 259 observations in the North Atlantic between 35°N and 59°N

AEL AMERICA - CALLSIGN PCEL

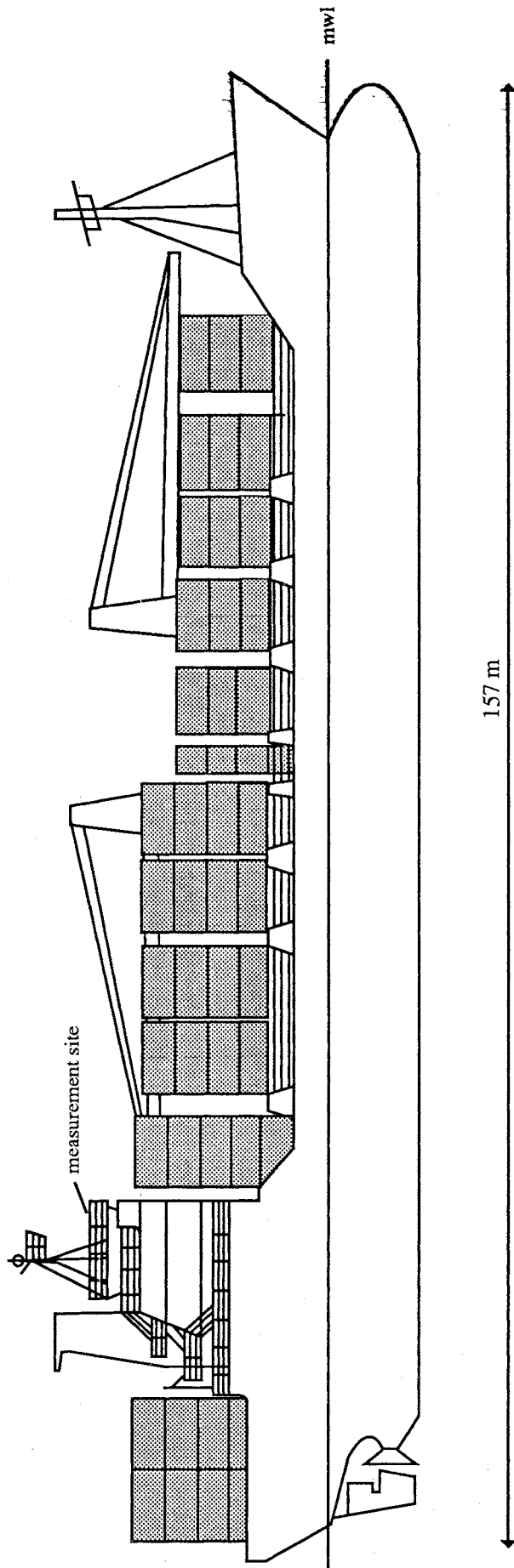

GULF SPEED - CALLSIGN PELT

Length: 203 m
 Breadth: 30.5 m
 Draft: 10.5 m
 Type: Container
 Recruiting Country: Netherlands
 Reference Level: 10±0.5 m asl

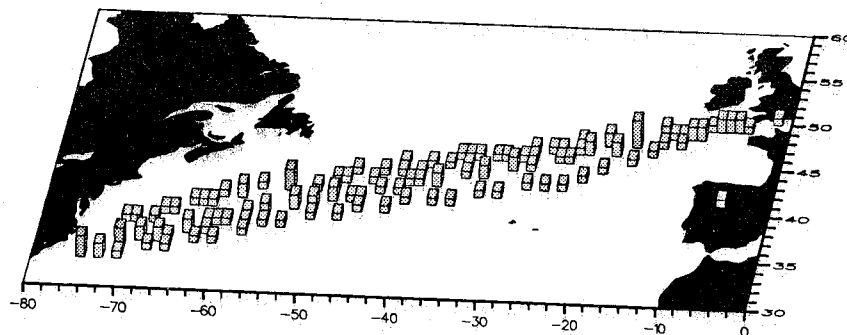
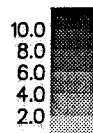

Instrument	Location	Instrument Type	Height ASL (m)	Height Above Deck (m)	Exposure				See Note
					315- 045	045- 135	135- 225	225- 315	
Anemometer	Not fitted								1
Screen	Not fitted								
Psychrometer	Used on port Bridge Wing		28	~1.5	4	1	8	8	2
Psychrometer	Used on starboard Bridge Wing		28	~1.5	4	8	8	1	2
Barometer	Wheelhouse	PAB	26						
SST	Intake Probe	PT100(CSI) thermometer	-6						

Note 1 The method of wind measurement is visual

Note 2 Bridge Wings are enclosed by a solid metal bulwark, to the rear of the Bridge Wings are open metal rails. No photographs are available so exposure ratings are estimated

The Gulf Speed has made 153 observations in the North Atlantic between 32°N and 51°N

GULF SPEED - CALLSIGN PELT

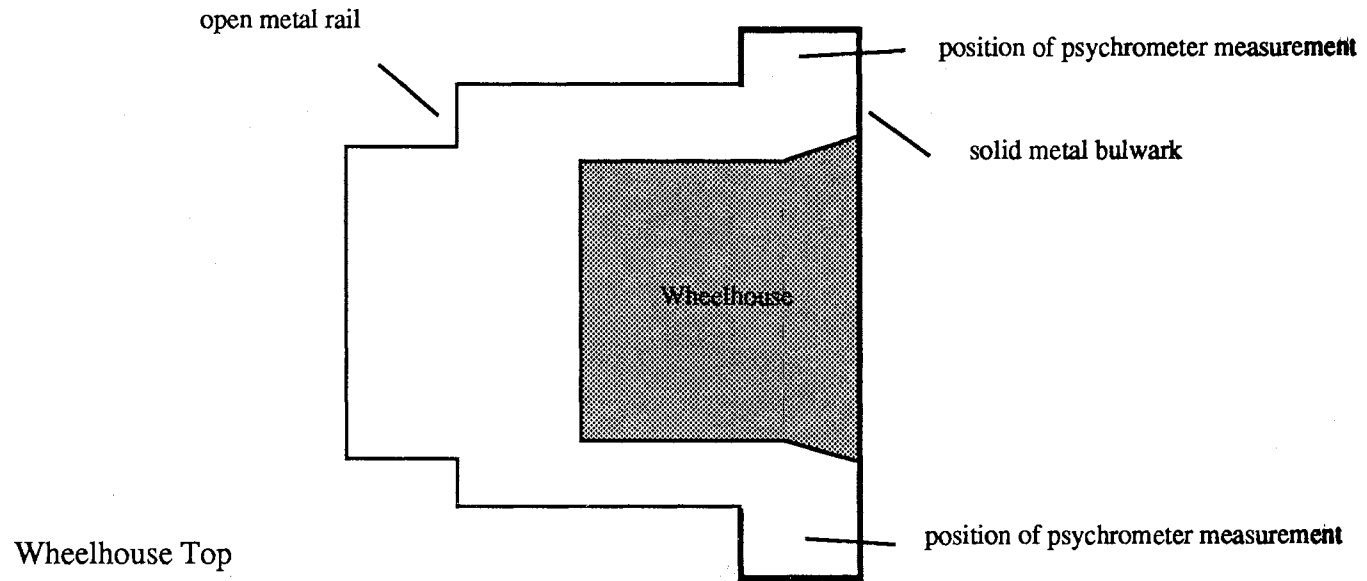
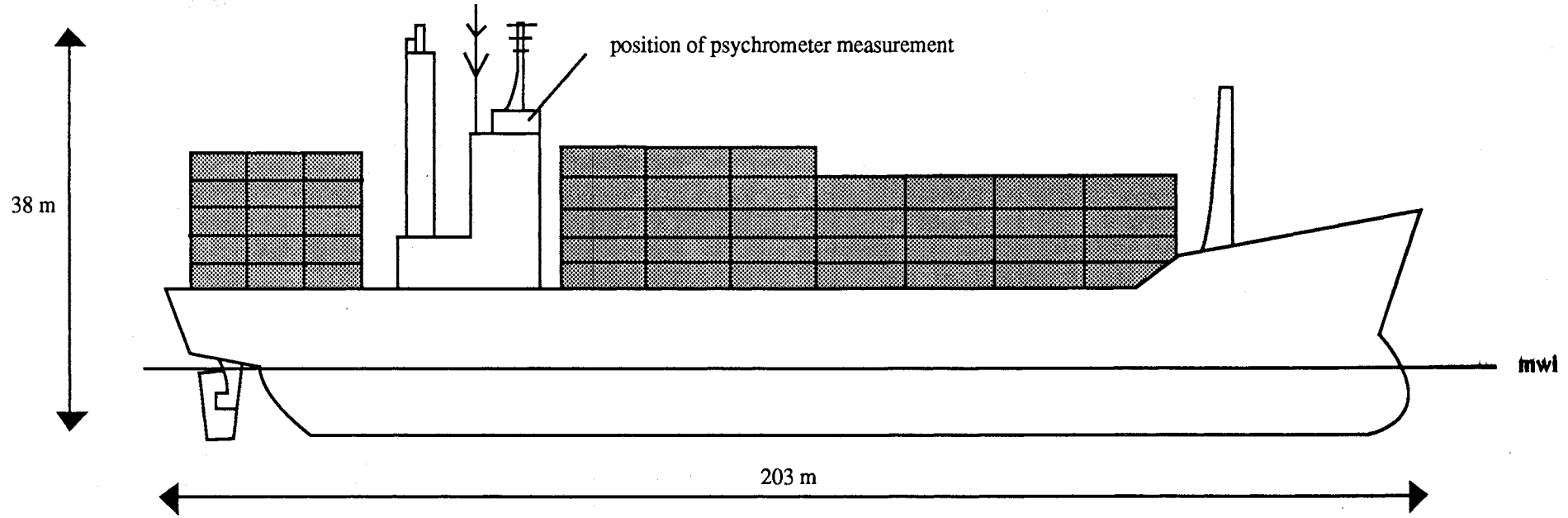

GULF SPIRIT - CALLSIGN PELU

Length: 203 m
 Breadth: 30.5 m
 Draft: 10.5 m
 Type: Container
 Recruiting Country: Netherlands
 Reference Level: 10±0.5 m asl

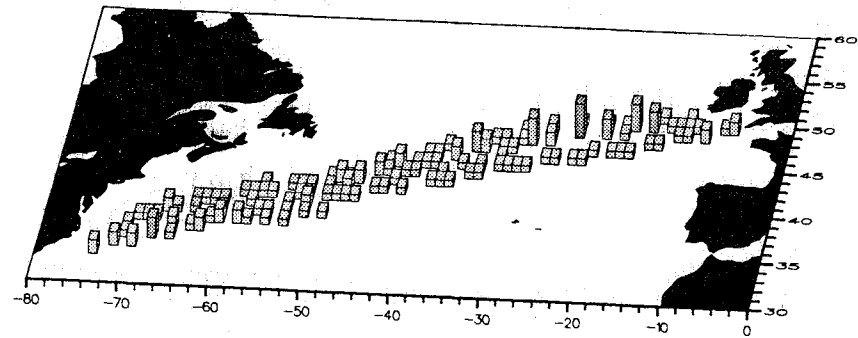
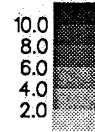

Instrument	Location	Instrument Type	Height ASL (m)	Height Above Deck (m)	Exposure				See Note
					315-045	045-135	135-225	225-315	
Anemometer	Not fitted								1
Screen	Not fitted								
Psychrometer	Used on port Bridge Wing		28	~1.5	4	1	8	8	2
Psychrometer	Used on starboard Bridge Wing	PAB	28	~1.5	4	8	8	1	2
Barometer	Wheelhouse		26						
SSI	Intake Probe	PT100(CSI) thermometer	-6						

Note 1 The method of wind measurement is visual

Note 2 Bridge Wings are enclosed by a solid metal bulwark, to the rear of the the Bridge Wing are open metal rails. No photographs were available so exposure ratings are estimated

The Gulf Spirit has made 175 observations in the North Atlantic between 32°N and 51°N

GULF SPIRIT - CALLSIGN PELU

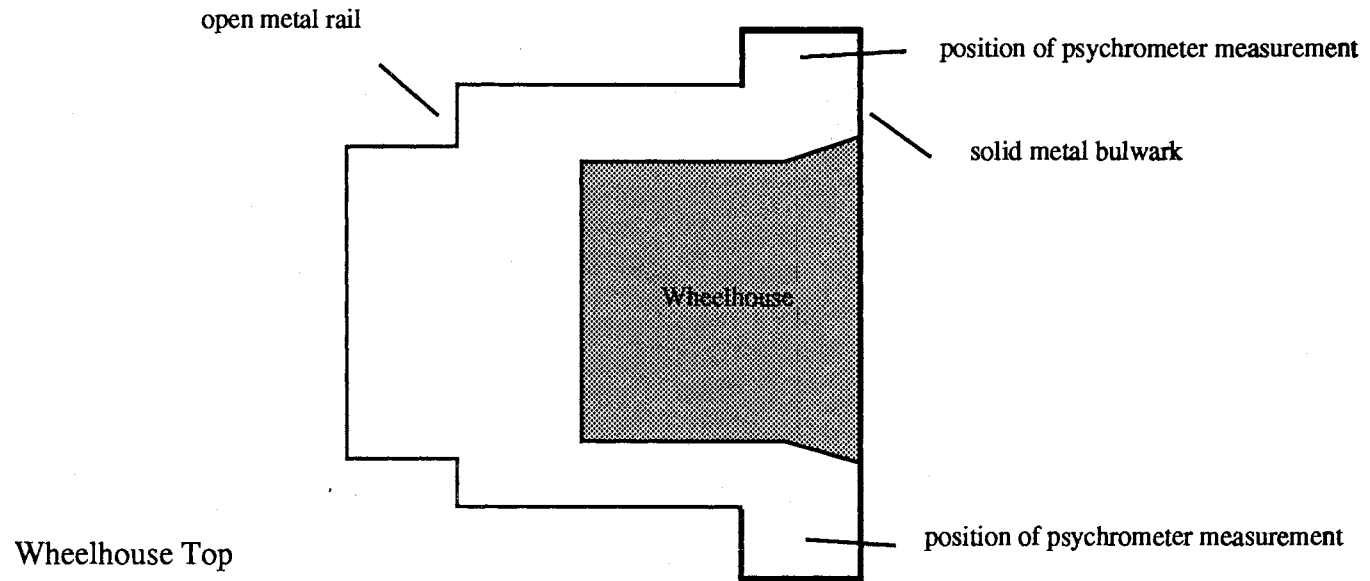
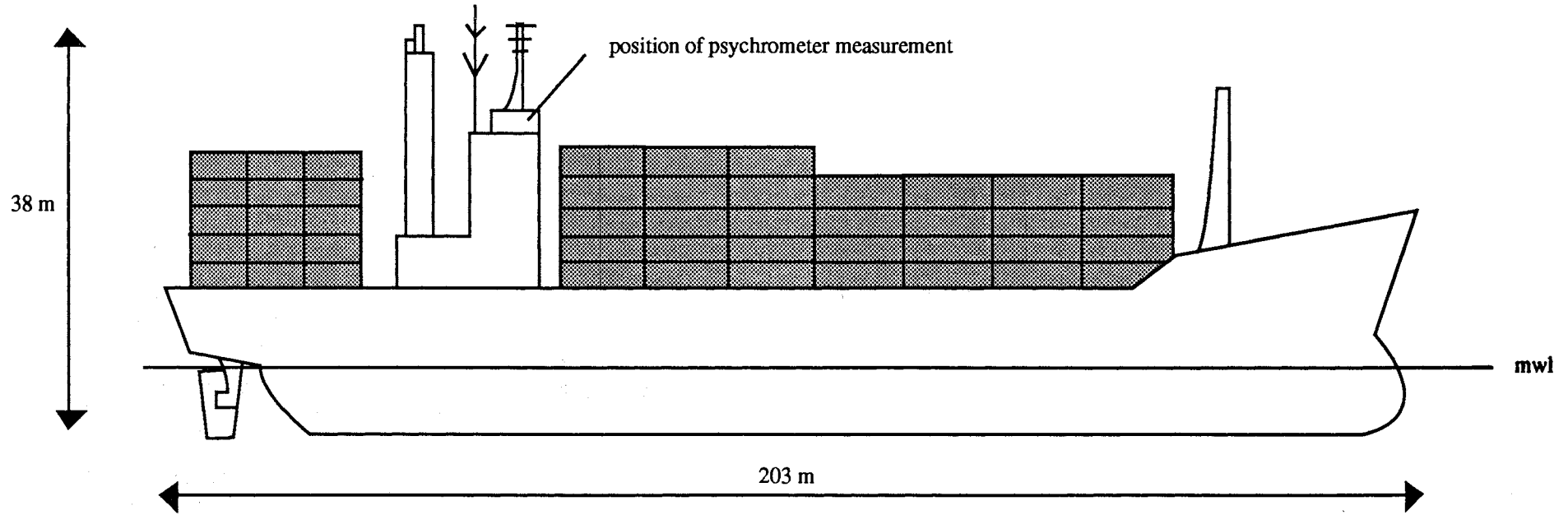

NEDLLOYD KINGSTON - CALLSIGN PGDG

Length: 163 m
 Breadth: 22 m
 Draft: 10 m
 Type: Container
 Recruiting Country: Netherlands
 Reference Level: 7±1 m asl

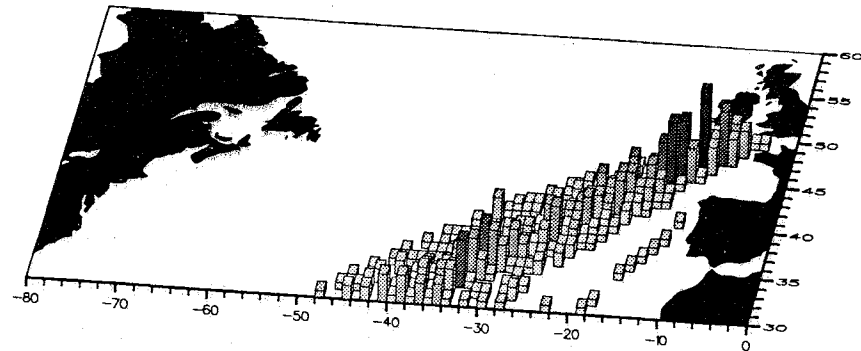
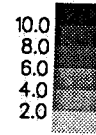

Instrument	Location	Instrument Type	Height ASL (m)	Height Above Deck (m)	Exposure				See Note
					315-045	045-135	135-225	225-315	
Anemometer	Not fitted								1
Screen	Not fitted								
Port Psychrometer	Used on port Bridge Wing	Sling KNMI	19	~1.5	8	1	8	8	2
Psychrometer	Used on Starboard Bridge Wing	Sling KNMI	19	~1.5	8	8	8	1	2
Aneroid Barometer	Wheelhouse	Negretti and Lambra N2236 PAB	19						
SST	Bucket or XBT	See Figure 17 e							3

Note 1 The method of wind measurement is visual

Note 2 Bridge Wings are enclosed by a solid metal bulwark, to the rear of the Bridge Wings are open metal rails. Thermometers are mercury

Note 3 The bucket or XBT is lowered from the port side of the Bridge Wing. The method of sea surface temperature measurement depends on the sea state, the bucket being used in calm conditions

The Nedlloyd Kingston has made 473 observations in the North Atlantic between 30°N and 50°N

NEDLLOYD KINGSTON - CALLSIGN PGDG

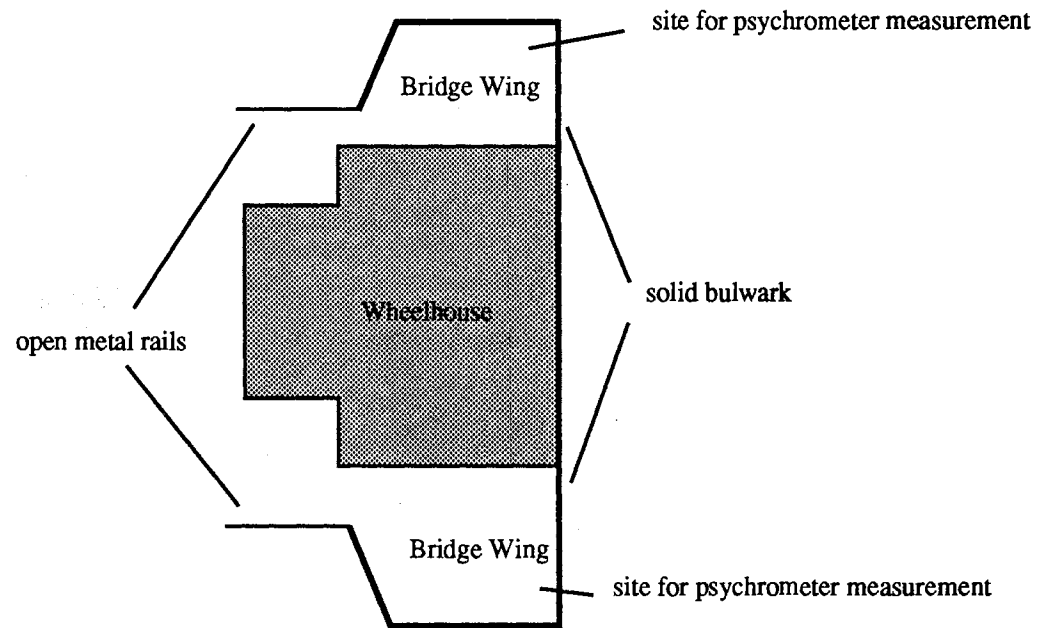
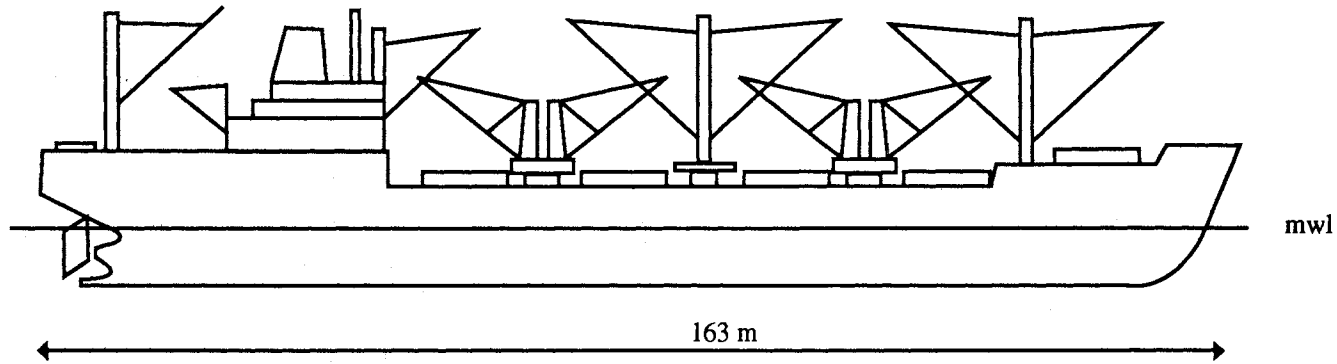

NEDLLOYD KYOTO - CALLSIGN PGDS

Length: 163 m
 Breadth: 22 m
 Draft: 10 m
 Type: Container
 Recruiting Country: Netherlands
 Reference Level: 7±1 m asl

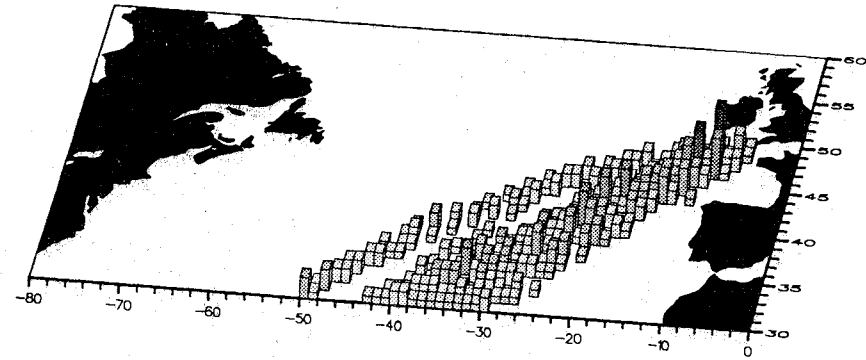
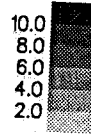

Instrument	Location	Instrument Type	Height ASL (m)	Height Above Deck (m)	Exposure				See Note
					315-045	045-135	135-225	225-315	
Anemometer	Not fitted								1
Screen	Not fitted								
Psychrometer	Used on port Bridge Wing	KNMI	19	~1.5	8	1	8	8	2
Psychrometer	Used on starboard Bridge Wing	KNMI	19	~1.5	8	8	8	1	2
Aneroid Barometer	Wheelhouse	No 1110/M/69 PAB	19						
SST	Bucket	See Figure 17 e							3

Note 1 The method of wind measurement is visual

Note 2 Bridge Wings are enclosed by a solid metal bulwark, to the rear of the Bridge Wings are open metal rails. Thermometers are mercury

Note 3 Bucket is lowered from the Bridge Wings

The Nedlloyd Kyoto has made 422 observations in the North Atlantic between 30°N and 50°N

NEDLLOYD KYOTO - CALLSIGN PGDS

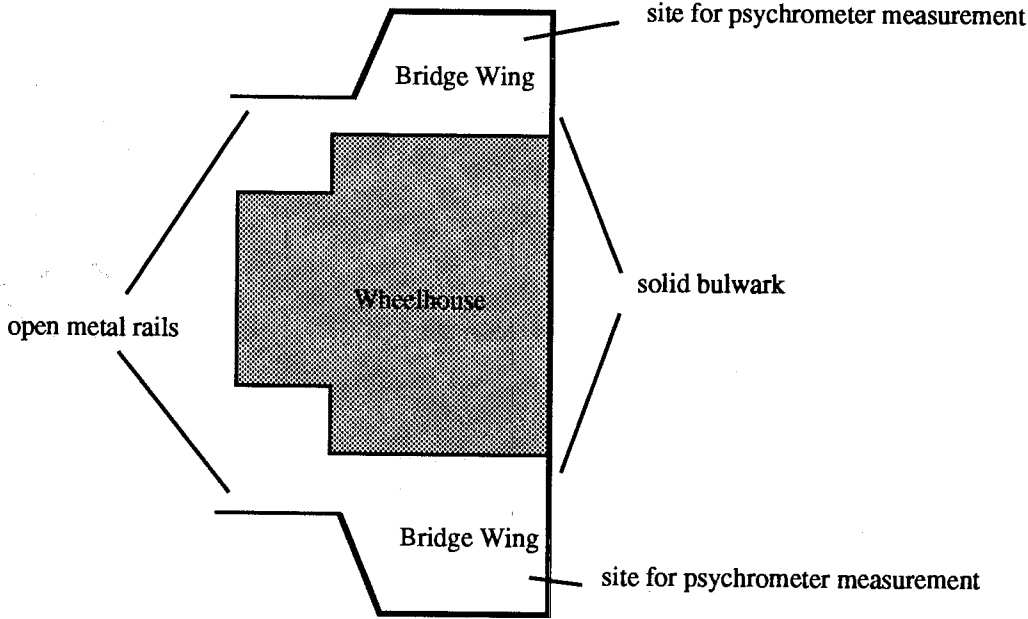
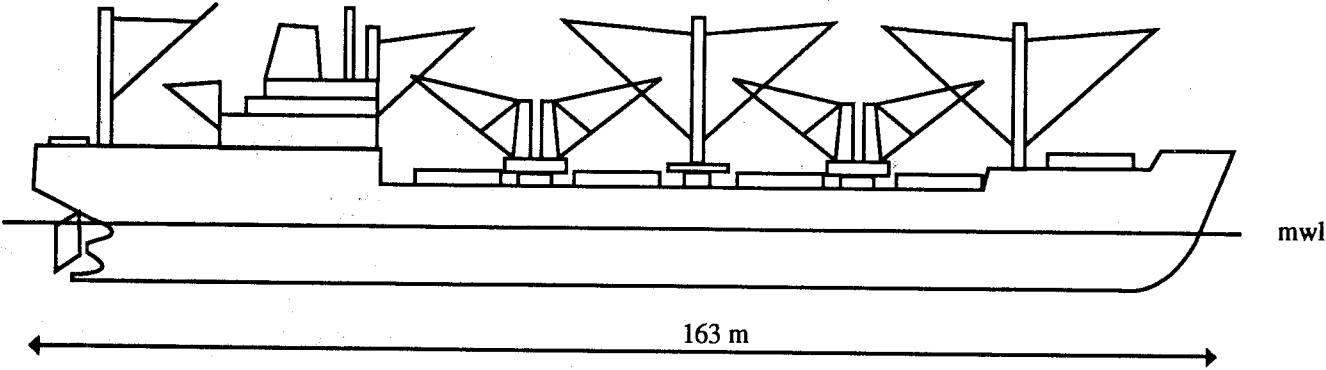

NEDLLOYD ZEELANDIA - CALLSIGN PGDW

Length: 207 m
 Breadth: 30 m
 Draft: 10 m
 Type: Container
 Recruiting Country: Netherlands
 Reference Level: 10±0.5 m asl

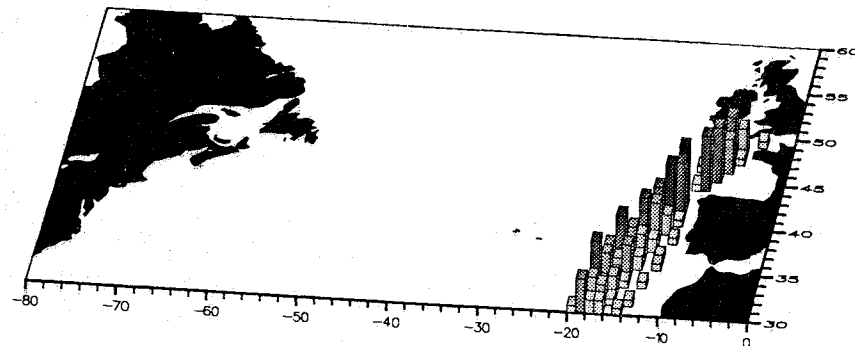
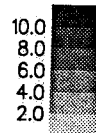

Instrument	Location	Instrument Type	Height ASL (m)	Height Above Deck (m)	Exposure				See Note
					315-045	045-135	135-225	225-315	
Anemometer	Not fitted								1
Screen	Not fitted								
Psychrometer	Used on port Bridge Wing	KNMI	26	~1.5	8	1	8	8	2
Psychrometer	Used on starboard Bridge Wing	KNMI	26	~1.5	8	8	8	1	2
Aneroid Barometer	Wheelhouse	PAB	26						
SST	Hull sensor								

Note 1 The method of wind measurement is visual

Note 2 Bridge Wings are enclosed by a solid metal bulwark, to the rear of the Bridge Wings are open metal rails. Thermometers are mercury

The Nedlloyd Zeelandia has made 197 observations in the North Atlantic between 30°N and 50°N

NEDLLOYD ZEELANDIA - CALLSIGN PGDW

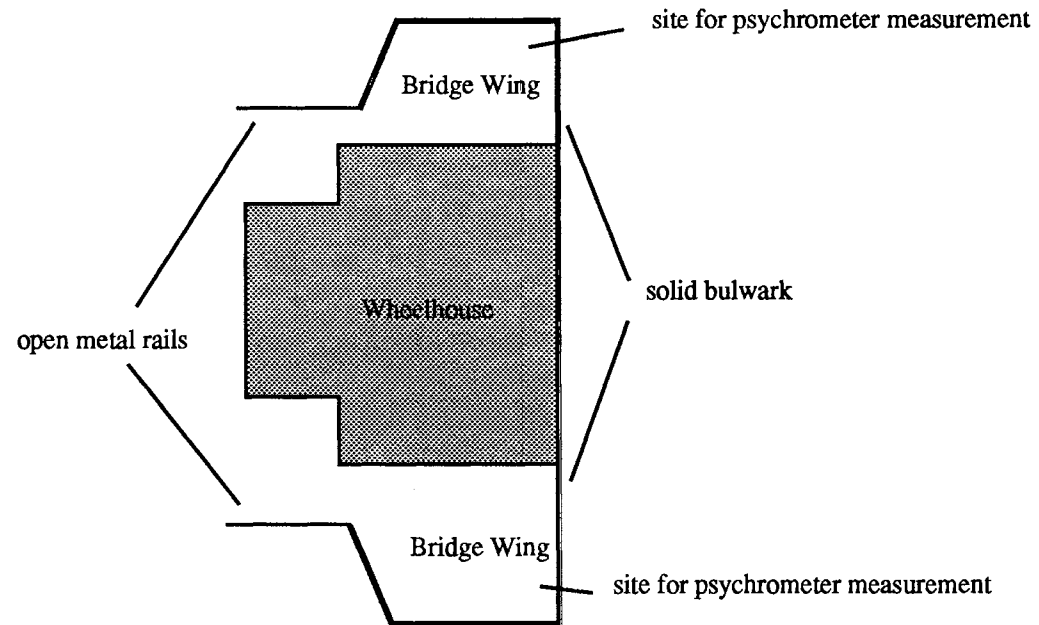
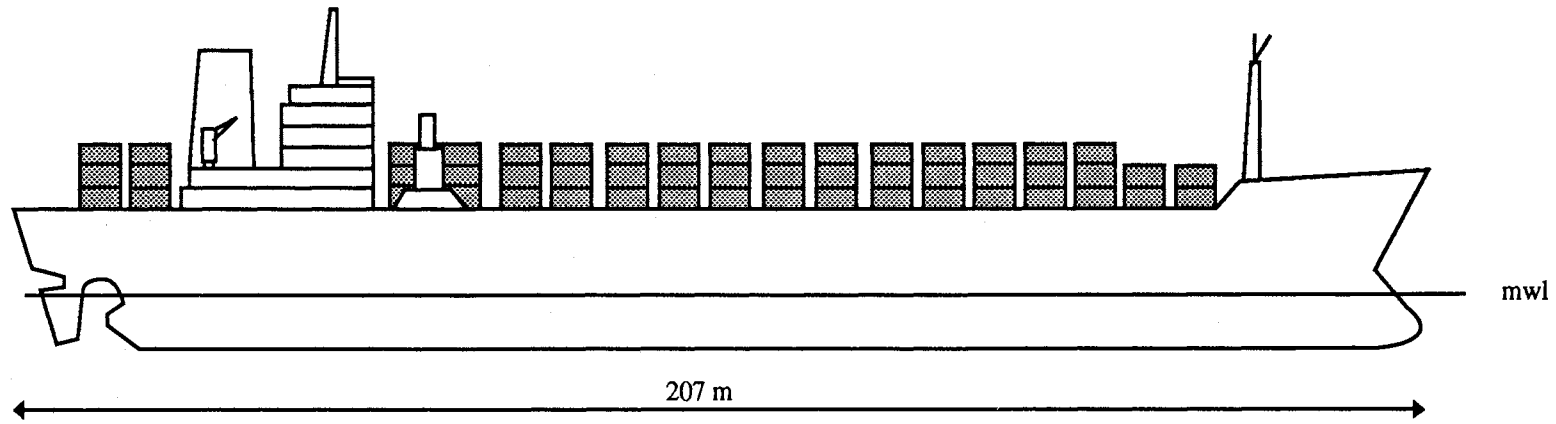

NEDLLOYD NEERLANDIA - CALLSIGN PGE6

Length: 204 m
 Breadth: 30 m
 Draft: 10 m
 Type: Container
 Recruiting Country: Netherlands
 Reference Level: 9±2 m asl

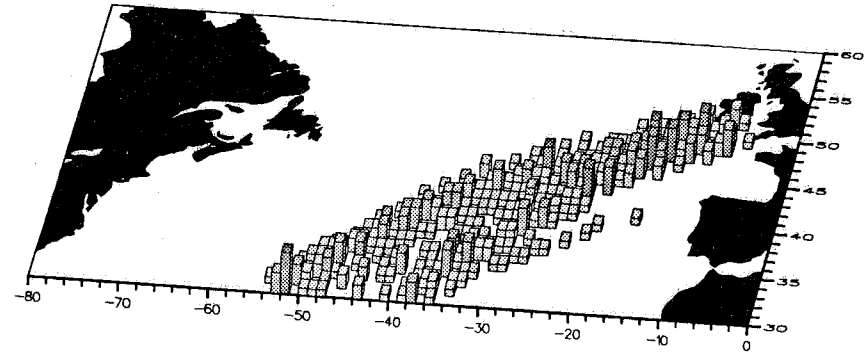
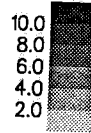

Instrument	Location	Instrument Type	Height ASL (m)	Height Above Deck (m)	Exposure				See Note
					315-045	045-135	135-225	225-315	
Anemometer	Handheld	Boosman	24		4	4	4	4	1
Screen	Not fitted								
Psychrometer	Used on port Bridge Wing	Sling KNMI	24	~1.5	4	1	8	8	2
Psychrometer	Used on starboard Bridge Wing	Sling KNMI	24	~1.5	4	8	8	1	2
Aneroid Barometer	Wheelhouse	PAB	25						
SST	Bucket	See Figures 17c and d							3

- Note 1 The method of wind measurement is visual
- Note 2 Bridge Wings are enclosed by a solid metal bulwark, to the rear of the Bridge Wings are open metal rails. Thermometers are mercury
- Note 3 Bucket is lowered from the Bridge Wings

The Nedlloyd Neerlandia has made 443 observations in the North Atlantic between 30°N and 52°N

NEDLLOYD NEERLANDIA - CALLSIGN PGEG

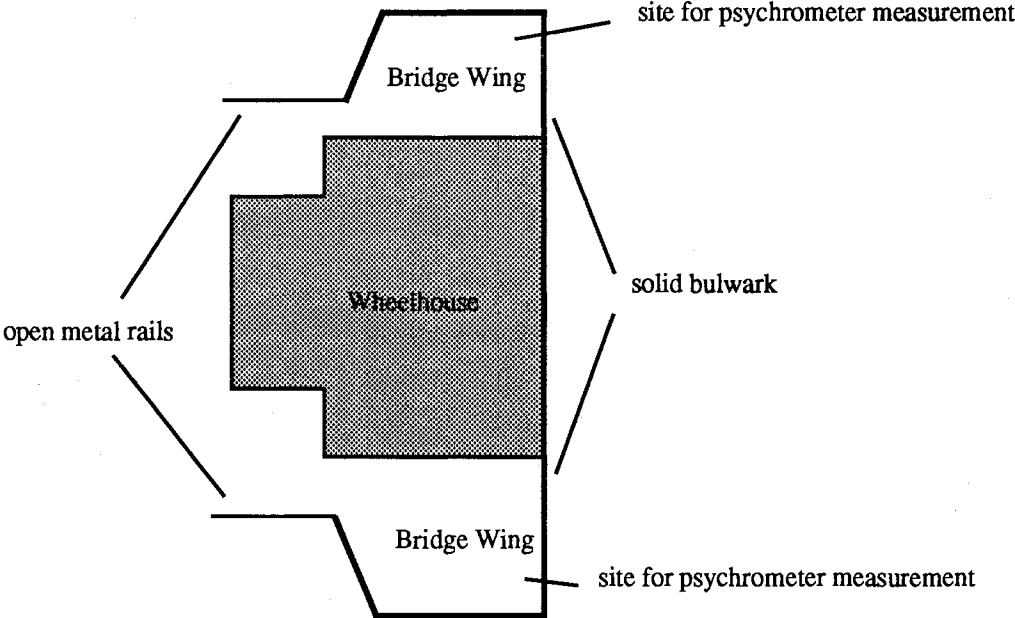
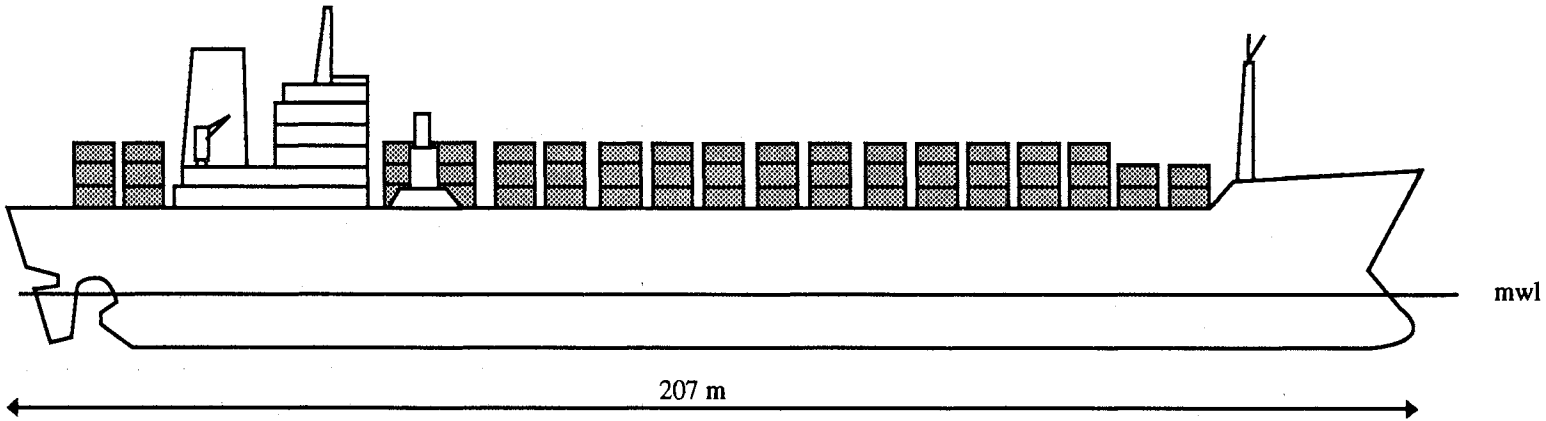

CUMULUS - CALLSIGN LIMA

Length: 71 m
 Breadth: 12.5 m
 Draft: 4.6 m
 Type: Ocean Weather Ship
 Recruiting Country: Britain
 Reference Level: ? m asl

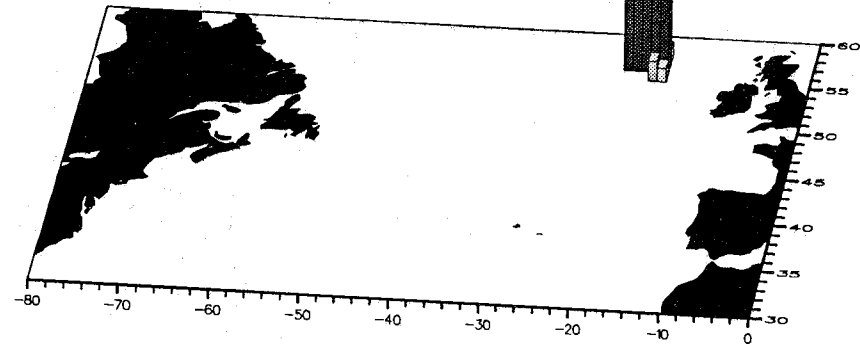
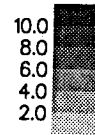

Instrument	Location	Instrument Type	Height ASL (m)	Height Above Deck (m)	Exposure				See Note
					315-045	045-135	135-225	225-315	
Anemometer x 2	Port and Starboard, Aft mast	Munroe Mk 4	23						
Port Screen	Wheelhouse Top	Electrical Resistance (remote read)	11	6					
Starboard Screen	Wheelhouse Top	Electrical Resistance (remote read)	11	6					
Psychrometer	Not fitted								
Barometer	Instrument Room	PAB	5.8						
SST	Hull Sensor		-1						

Note The Cumulus dataset does not include codes for instrumentation

The Cumulus has made 3846 observations in the North Atlantic at 18-22°W by 56-57°N

O.W.S. CUMULUS - CALLSIGN LIMA

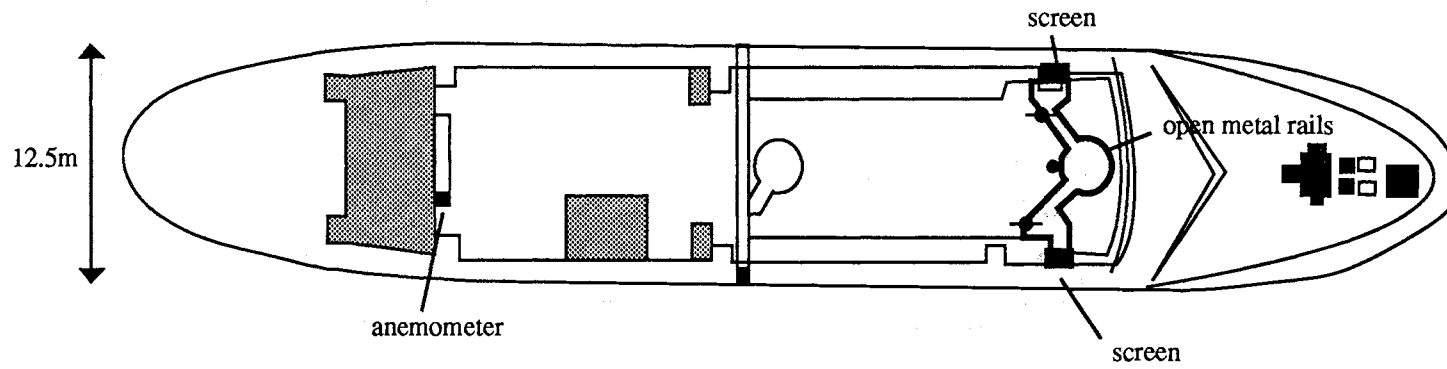
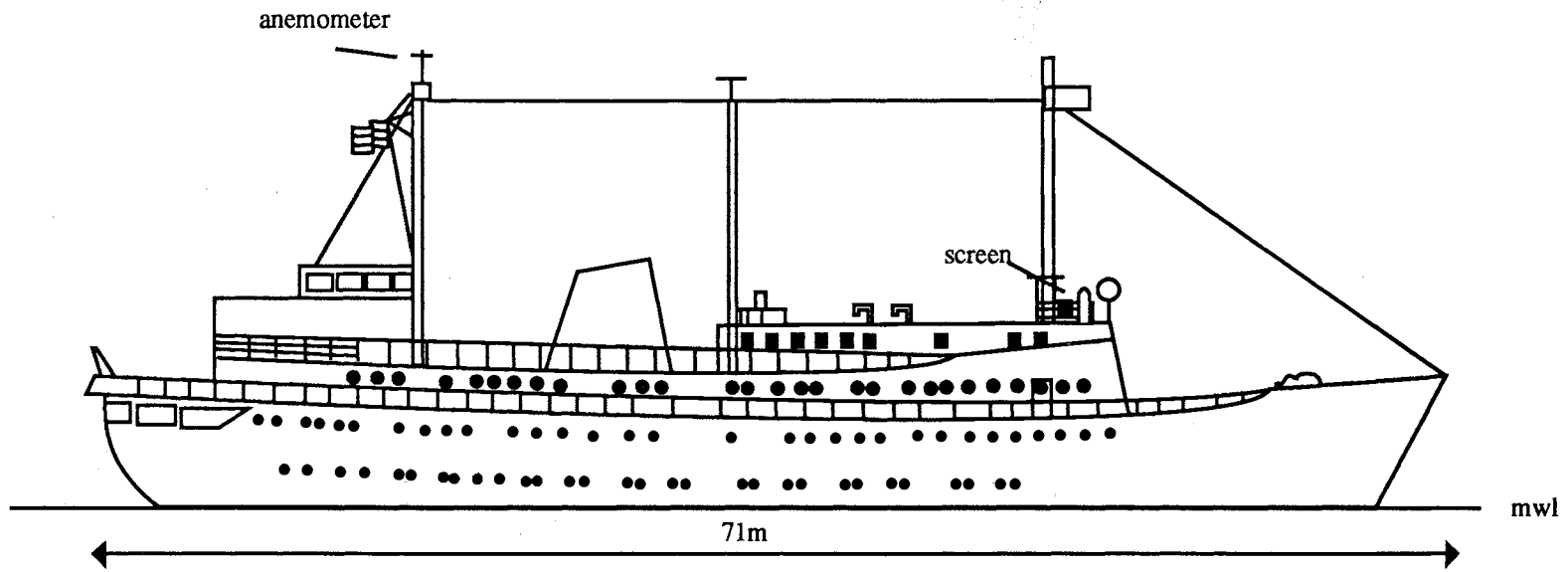

ATLANTIC LINK - CALLSIGN C6DS

Length: 145.5 m
 Breadth: 20.5 m
 Draft: 5 m
 Type: Closed Container
 Recruiting Country: Britain
 Reference Level: 13±1 m asl

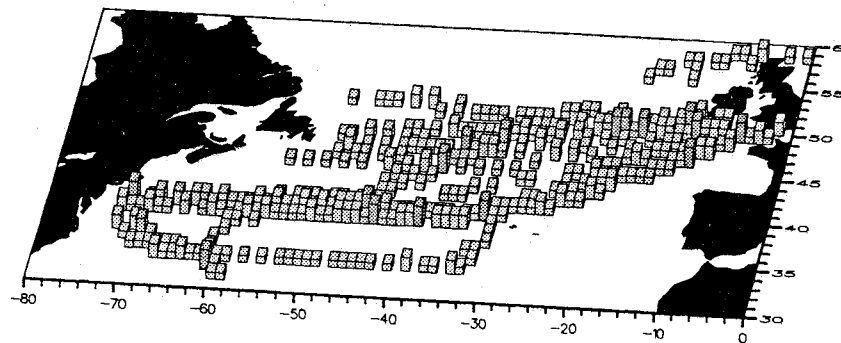
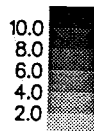

Instrument	Location	Instrument Type	Height ASL (m)	Height Above Deck (m)	Exposure				See Note
					315-045	045-135	135-225	225-315	
Anemometer	Not fitted								1
Port Screen	Bridge Wings	Marine Screen	13	~1	3	0	6	4	2
Starboard Screen	Bridge Wings	Marine Screen	13	~1	3	4	6	0	2
Psychrometer	Not fitted								
Aneroid Barometer	Wheelhouse	Barograph, PAB	13						
SST	Bucket	Rubber							

Note 1 The method of wind measurement is visual

Note 2 The screens are lashed to the side of the wheelhouse and are positioned 3 m inboard and clear of the superstructure. To the front is a wind deflector on a solid metal bulwark, to the side a solid metal bulwark and to the rear, open metal rails around the large enclosed cargo area. Thermometers are mercury

The Atlantic Link has made 511 observations in the North Atlantic between 58°N and 31°N

ATLANTIC LINK - CALLSIGN C6DS

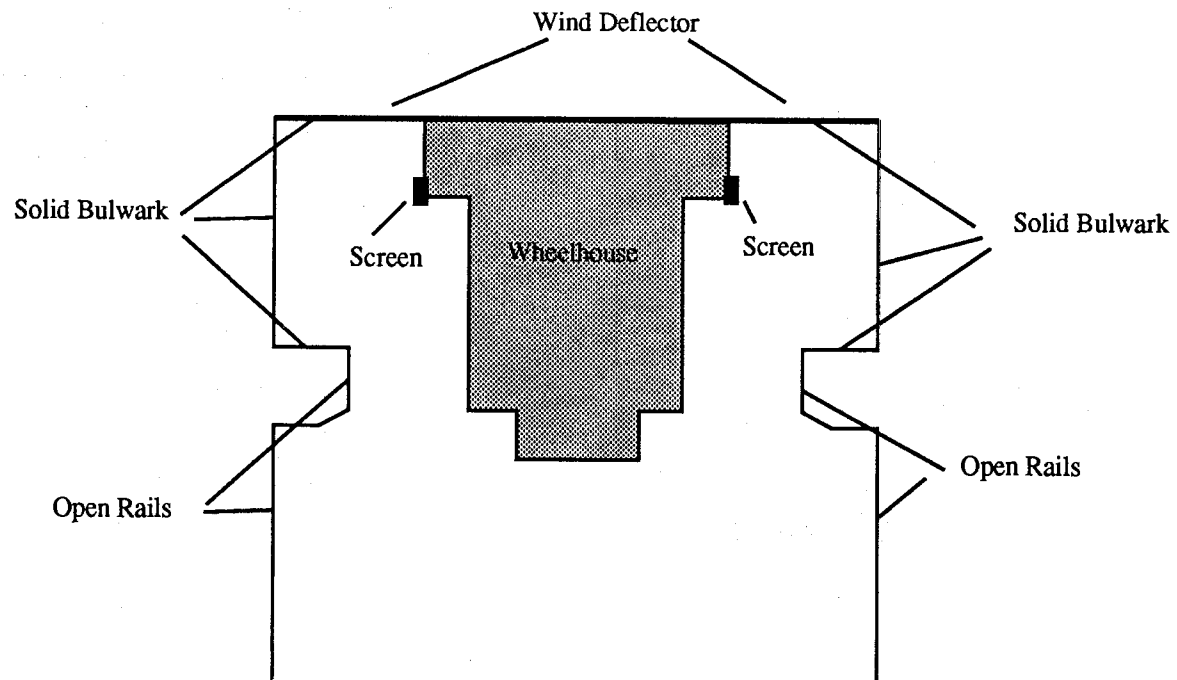
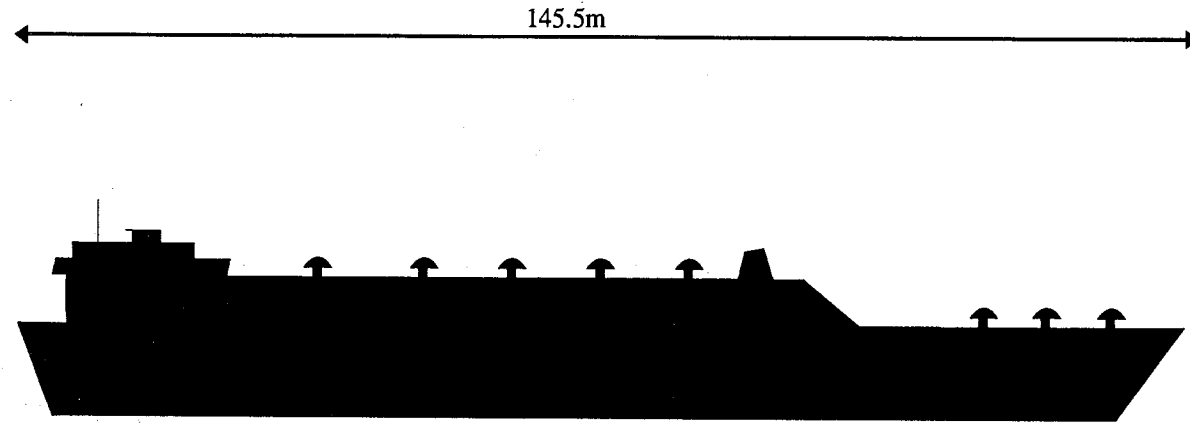

AUTHOR - CALLSIGN GBSA

Length: 204 m
 Breadth: 31 m
 Draft: 11 m
 Type: Container
 Recruiting Country: Britain
 Reference Level: 25±1 m asl

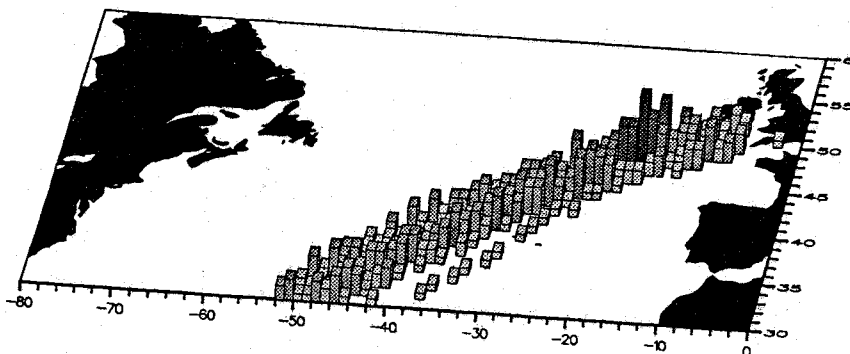
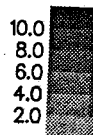

Instrument	Location	Instrument Type	Height ASL (m)	Height Above Deck (m)	Exposure				See Note
					315-045	045-135	135-225	225-315	
Anemometer	Port Yard-arm on mainmast	Walker	39		9	9	9	9	1
Port Screen	Wheelhouse Top	Marine Screen	27	1.5	5	1	7	5	2
Starboard Screen	Wheelhouse Top	Marine Screen	27	1.5	4	5	7	1	2
Psychrometer	Not fitted								
Aneroid Barometer	Chartroom	PAB	27	~1.5					
SST	Bucket	Rubber		~1.5					

Note 1

The method of wind measurement is visual

Note 2

The deck is made of steel and the screens are mounted on posts with a solid metal bulwark to the front and open metal rails behind. Both screens are 17 m forward of the funnel. Thermometers are mercury

The Author has made 456 observations in the North Atlantic between 52°N and 30°N

AUTHOR - CALLSIGN GBSA

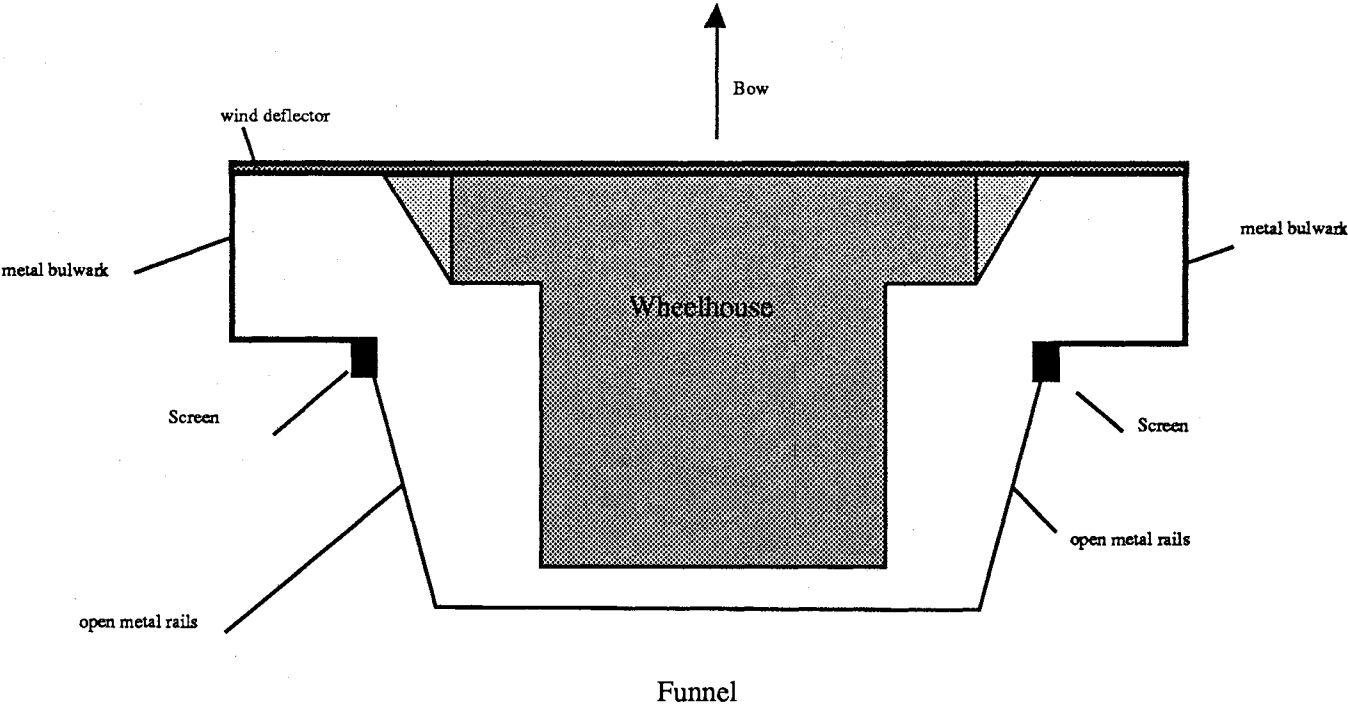
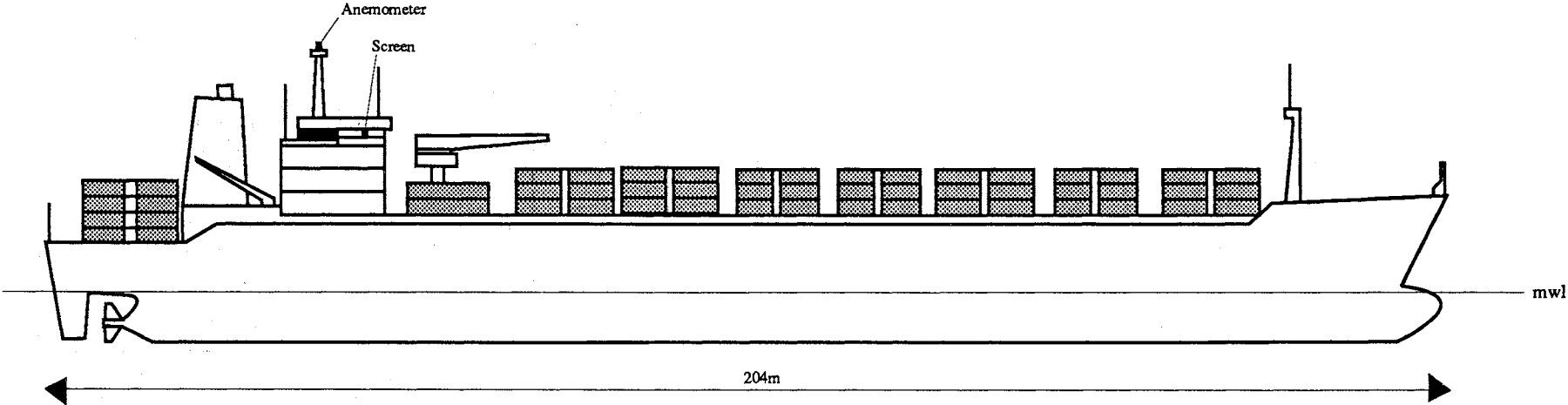

GEESTBAY - CALLSIGN GBVV

Length: 159 m
 Breadth: 21.5 m
 Draft: 8.8 m
 Type: Container / Banana
 Recruiting Country: Britain
 Reference Level: 16±2 m asl

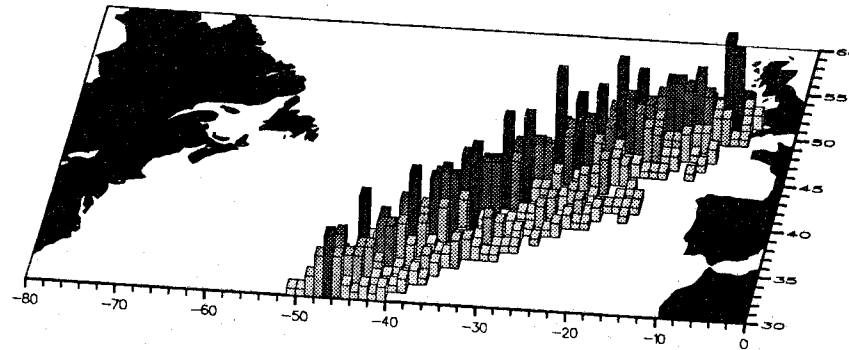
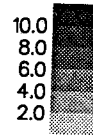

Instrument	Location	Instrument Type	Height ASL (m)	Height Above Deck (m)	Exposure				See Note
					315-045	045-135	135-225	225-315	
Anemometer	Not fitted								1
Port Screen	0.5 m above Bridge Wing bulwark	Marine Screen	16	1.5	8	1	7	9	2
Starboard Screen	0.5 m above Bridge Wing bulwark	Maine Screen	16	1.5	8	9	7	1	2
Psychrometer	Not fitted								
Aneroid Barometer	Chartroom	PAB Barograph	16						
SST	Bucket	Rubber							3
SST	Engine Intake / Hull Sensor		-7						3

Note 1 The method of wind measurement is visual

Note 2 Screens are positioned on the Bridge Wings, clear of the funnel and superstructure and have good exposure but are partially sheltered by wind deflectors to the front. The screens are hung on hooks secured to stanchions above the solid bulwark. The deck below the screens is wood sheathed. Thermometers are electric resistance

Note 3 The Geestbay had a hull sensor fitted in September 1989 but in March 1990 the sensor ring was found to be cracked and detached from the ships' side plate. The damage probably occurred ~19 February 1990. The rubber bucket is used from the lee Bridge Wing for SST measurements when weather permits

The Geestbay has made 1011 observations in the North Atlantic between 52°N and 30°N

GEEST BAY - CALLSIGN GBVV

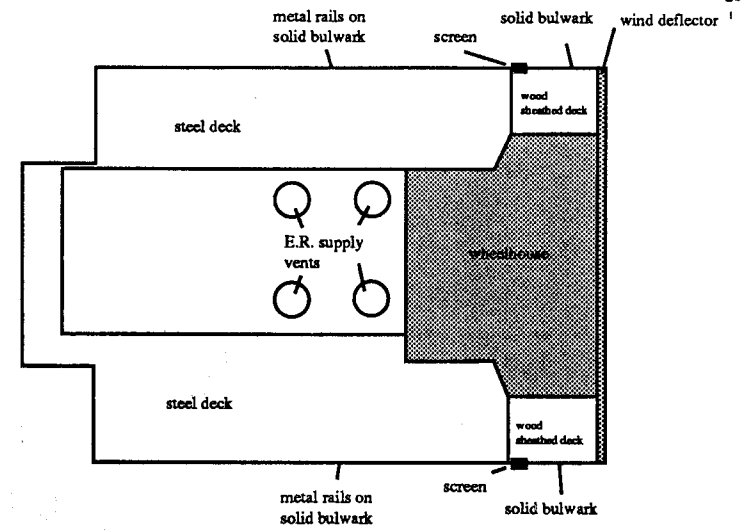
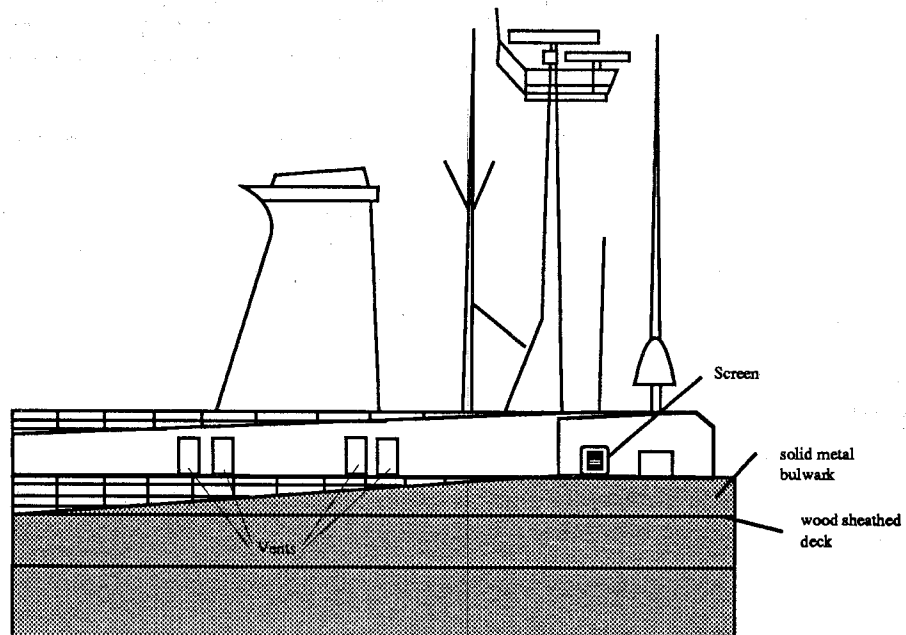
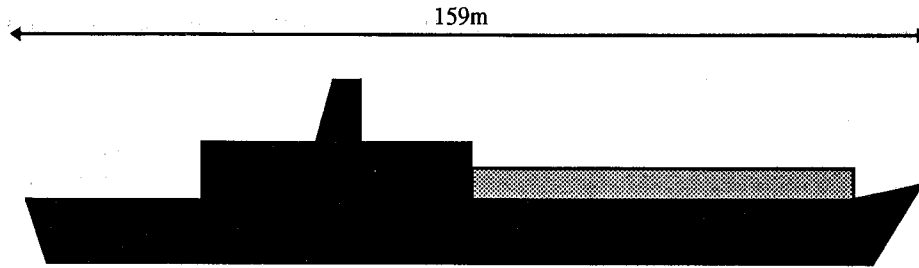

Navigation Bridge Deck

GEESTPORT - CALLSIGN GBVW

Length: 159 m
 Breadth: 21.5 m
 Draft: 8.8 m
 Type: Container / Banana
 Recruiting Country: Britain
 Reference Level: 16±2 m asl

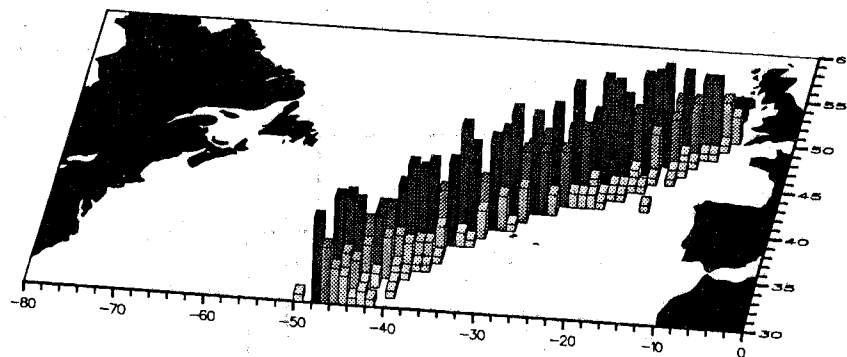
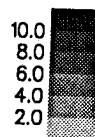

Instrument	Location	Instrument Type	Height ASL (m)	Height Above Deck (m)	Exposure				See Note
					315-045	045-135	135-225	225-315	
Anemometer	Not fitted								1
Port Screen	Side of Wheelhouse	Marine Screen	16	1	4	7	3	3	2
Starboard Screen	Side of Wheelhouse	Marine Screen	16	1	5	3	3	7	2
Psychrometer	Not fitted								
Aneroid Barometer	Chartroom	PAB Barograph	~16	1.3					
SST	Hull Sensor		-3						

- Note 1 The method of wind measurement is visual
 Note 2 Screens are suspended by hooks on stanchions 7 m inboard, 3.2 m from each funnel and are partially sheltered by the bulwark and funnel but are clear of the superstructure. The deck below the screens is made of steel. Thermometers are electric resistance

The Geestport has made 944 observations in the North Atlantic between 52°N and 30°N

GEESTPORT - CALLSIGN GBVW

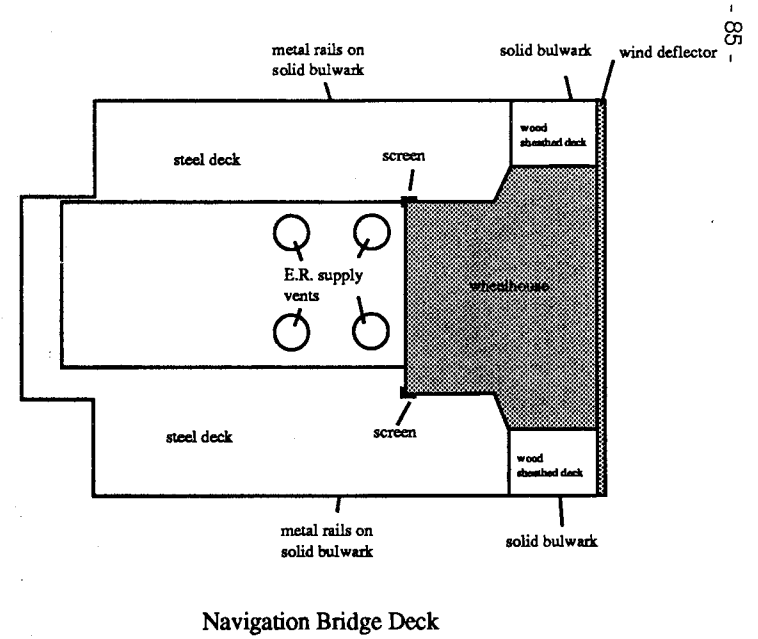
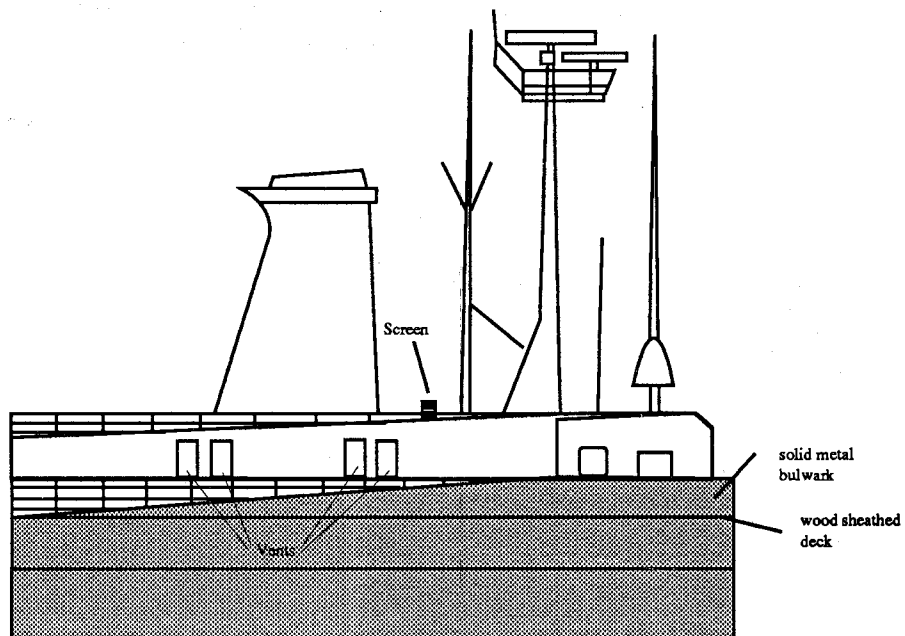
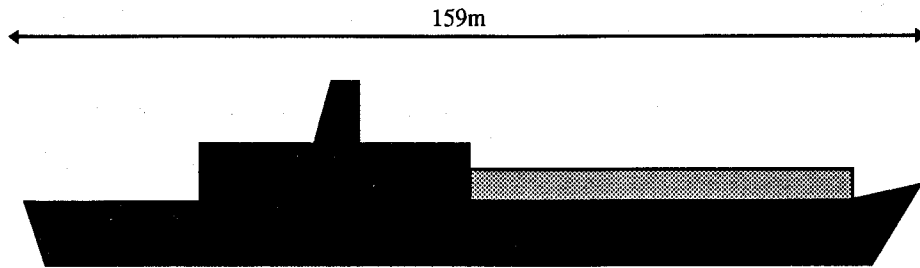

GEESTCAPE - CALLSIGN GJMR

Length: 157.5 m
 Breadth: 22.5 m
 Draft: 9.1 m
 Type: Container / Banana
 Recruiting Country: Britain
 Reference Level: 20 m asl

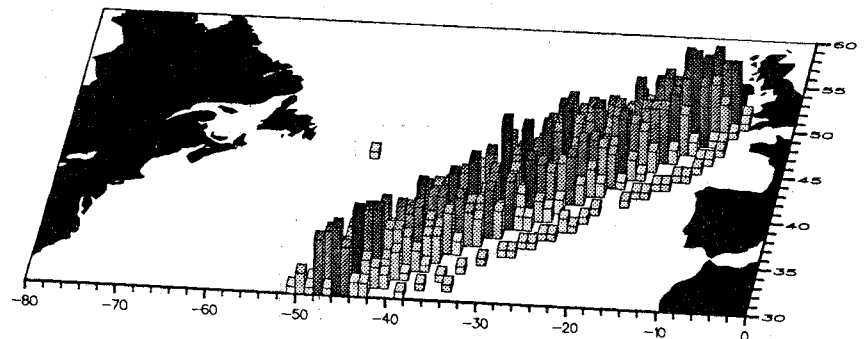
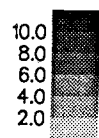

Instrument	Location	Instrument Type	Height ASL (m)	Height Above Deck (m)	Exposure				See Note
					315-045	045-135	135-225	225-315	
Anemometer	Not fitted								1
Port Screen	Bridge Wing	Marine Screen	20	1.3	4	1	6	9	2
Starboard Screen	Bridge Wing	Marine Screen	20	1.3	4	9	6	1	2
Psychrometer	Not fitted								
Aneroid Barometer	Chartroom	PAB Barograph							
SST	Engine Room Intake / Hull Sensor		-3						3

- Note 1 The method of wind measurement is visual
- Note 2 The screens are well exposed on the Bridge Wings but stand directly on a solid metal bulwark above a steel deck covered by rubber matting. Thermometers are electric resistance
- Note 3 The Geestcape had a Hull Sensor fitted in November 1989

The Geestcape has made 1184 observations in the North Atlantic between 52°N and 30°N

GEESTCAPE - CALLSIGN GJMR

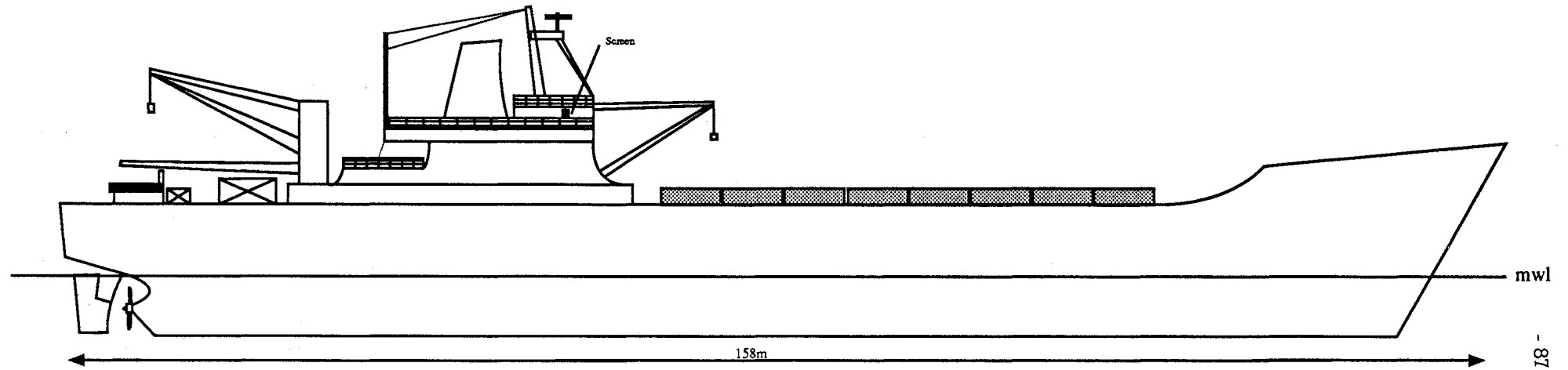

mwl

158m

- 87 -

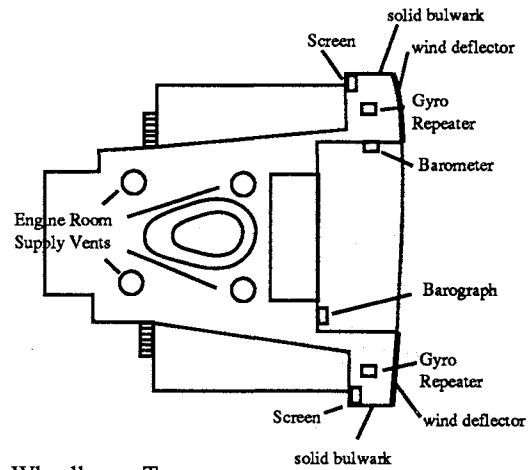

Wheelhouse Top

GEESTHAVEN - CALLSIGN GJMS

Length: 157.5 m
 Breadth: 22.5 m
 Draft: 9.1 m
 Type: Container / Banana
 Recruiting Country: Britain
 Reference Level: 25±0.5 m asl

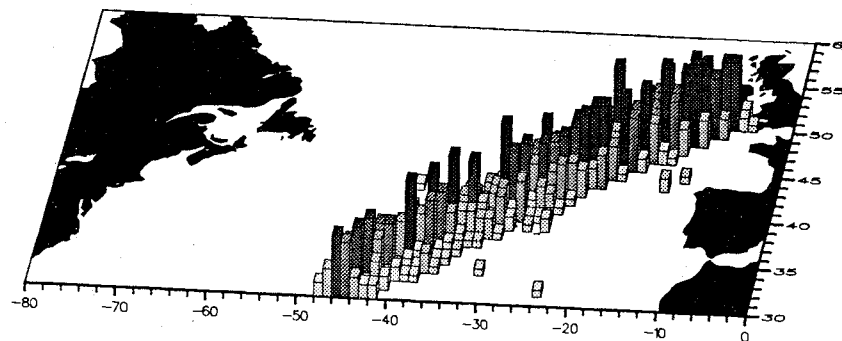
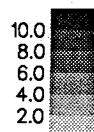

Instrument	Location	Instrument Type	Height ASL (m)	Height Above Deck (m)	Exposure				See Note
					315-045	045-135	135-225	225-315	
Anemometer	Not fitted								1
Port Screen	Bridge Wing	Marine Screen	18	1.3	4	1	6	9	2
Starboard Screen	Bridge Wing	Marine Screen	18	1.3	4	9	6	1	2
Psychrometer	Not fitted								
Aneroid Barometer	Chartroom	PAB Barograph	~20						
SST	Engine Room Intake / Hull Sensor		-5.5						3

Note 1 The method of wind measurement is visual

Note 2 The screens are well exposed on the Bridge Wings but stand directly on a solid metal bulwark above a steel deck covered by rubber matting. Thermometers are electric resistance

Note 3 The Geesthaven had a Hull Sensor fitted in August 1989

The Geesthaven has made 868 observations in the North Atlantic between 52°N and 30°N

GEESTHAVEN - CALLSIGN GJMS

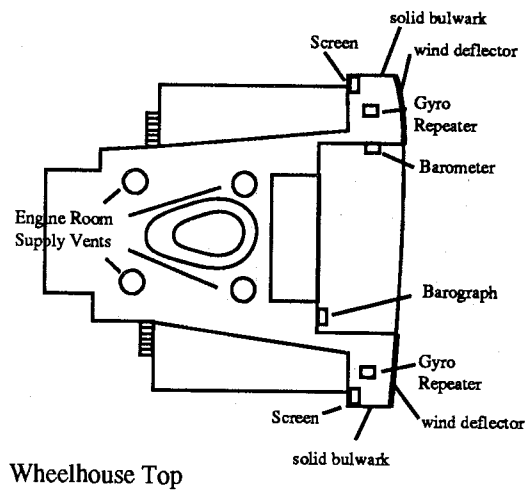
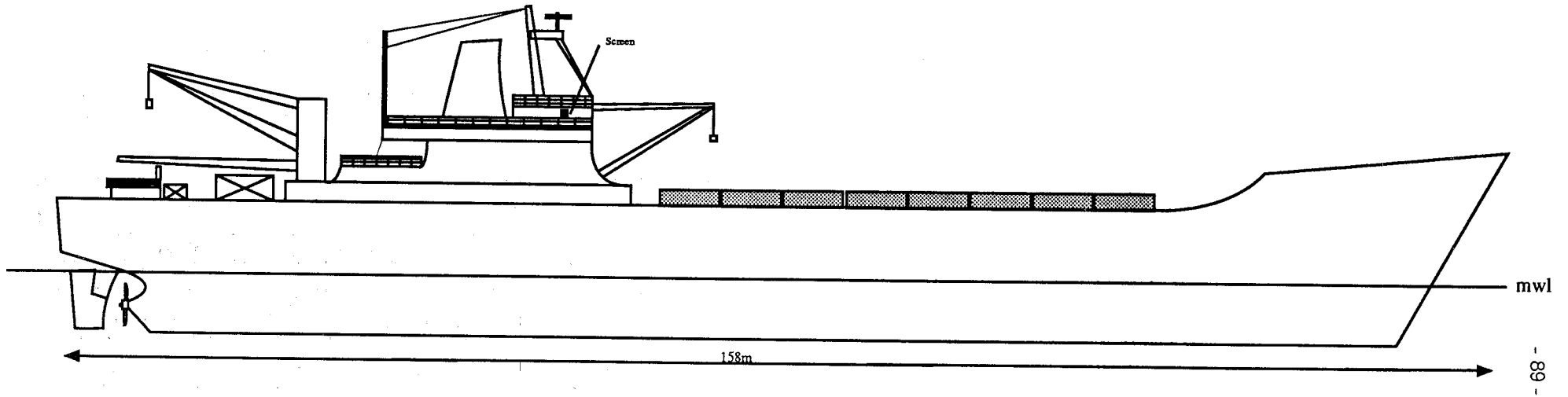

Wheelhouse Top

PROVENCE - CALLSIGN GXES

Length: 203.8 m
 Breadth: 31 m
 Draft: 10 m
 Type: Container
 Recruiting Country: Britain
 Reference Level: 25±0.5 m asl

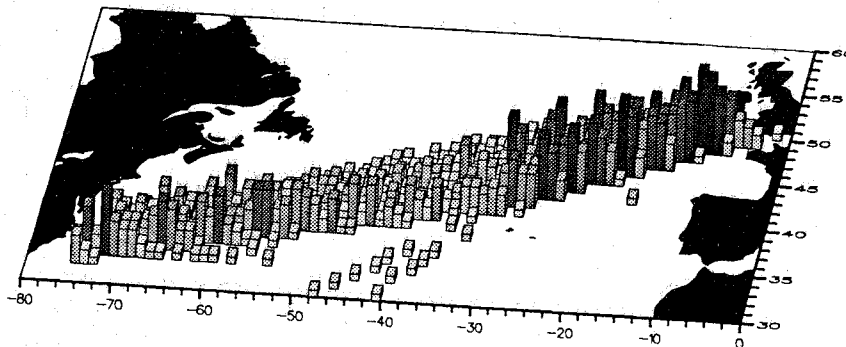
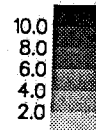

Instrument	Location	Instrument Type	Height ASL (m)	Height Above Deck (m)	Exposure				See Note
					315-045	045-135	135-225	225-315	
Anemometer	Port Yard-arm	Walker	37		9	9	9	9	1
Port Screen	0.5 m above Bridge Wing rails	Marine Screen	25	1.5	7	5	9	9	2
Starboard Screen	0.5 m above Bridge Wing rails	Marine Screen	25	1.5	7	9	9	5	2
Psychrometer	Not fitted								
Digital Barometer	Chartroom	PAB Barograph	25	~1.5					
SST	Bucket	Rubber							3
SST	Intake		-9						3

- Note 1 The method of wind measurement is visual
- Note 2 Screens are well exposed and are positioned on a post above an open metal rail 3 m inboard. Both screens are close to the funnel. Thermometers are mercury
- Note 3 The method of SST measurement is reported with each observation

The Provence has made 1141 observations in the North Atlantic between 51°N and 30°N

PROVENCE - CALLSIGN GXES

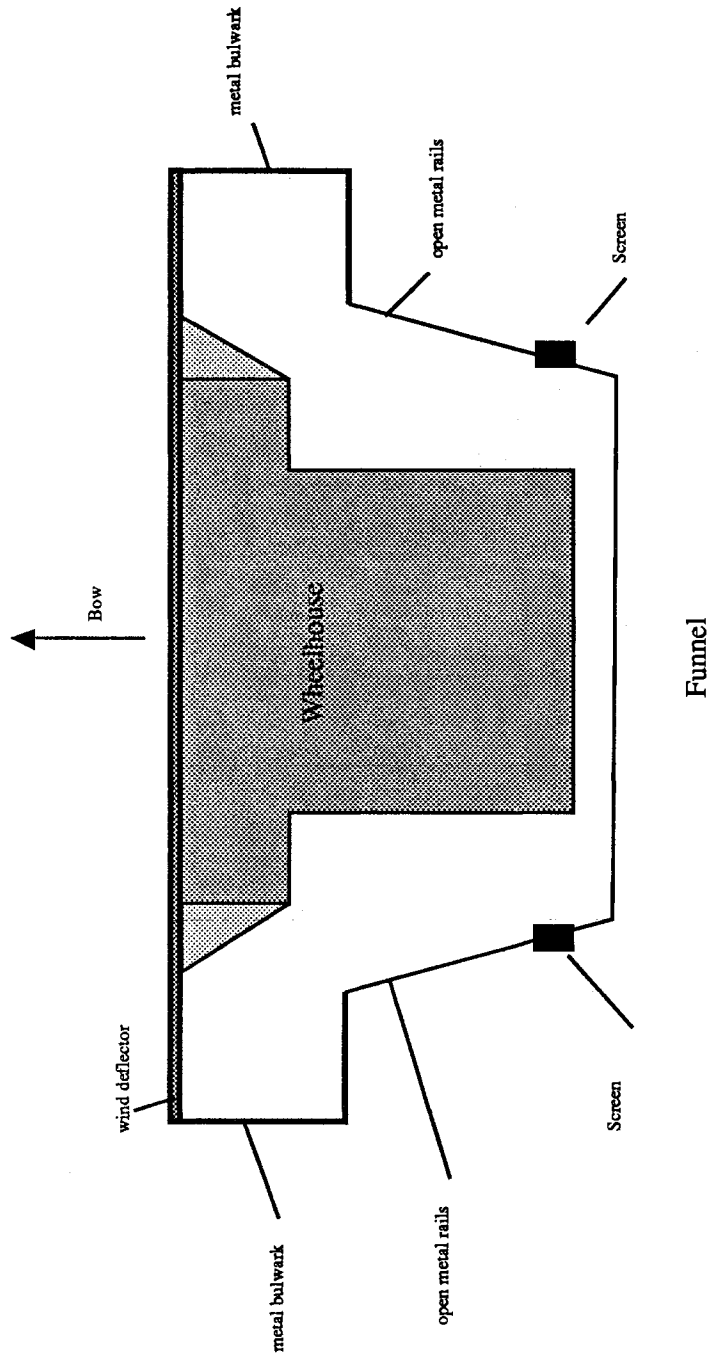
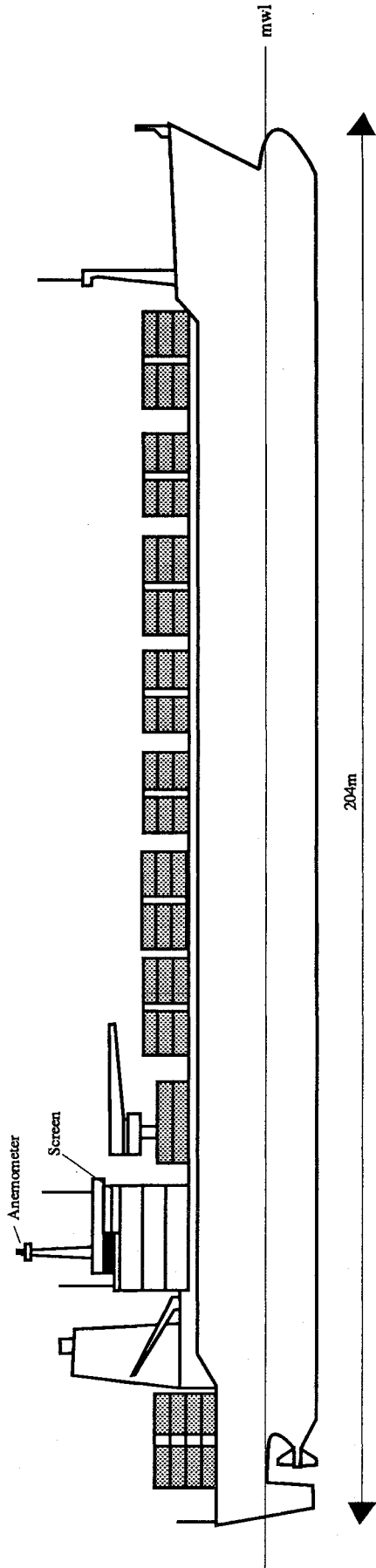

ATLANTIC CONVEYOR - CALLSIGN GZMM

Length: 293 m
 Breadth: 32 m
 Draft: 10 m
 Type: Container, Ro-ro
 Recruiting Country: Britain
 Reference Level: 33±1 m asl

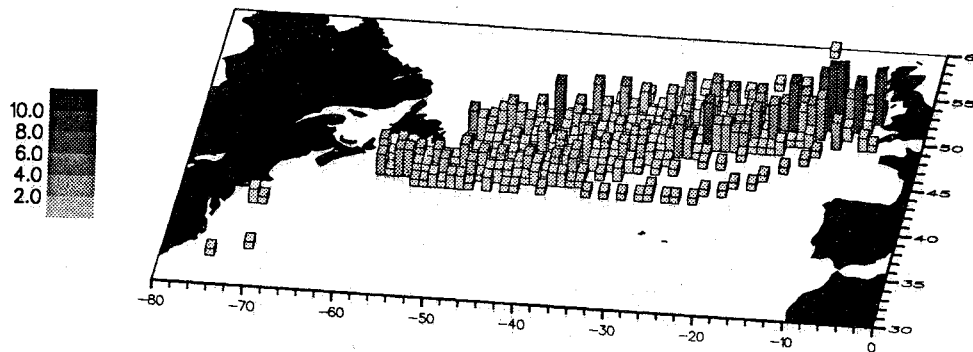

Instrument	Location	Instrument Type	Height ASL (m)	Height Above Deck (m)	Exposure				See Note
					315-045	045-135	135-225	225-315	
Anemometer	Signal Mast	Thomas Walker	43	7	7	4	4	7	1
Port Screen	Not fitted								
Starboard Screen	Wheelhouse Top	Marine Screen	37	1.3	7	3	7	6	2
Psychrometer	Not fitted								
Aneroid Barometer	Wheelhouse	PAB, Barograph	34	~1.5					
SST	Hull Sensor		-4						

- Note 1 The anemometer is positioned 1.5 m from the mast with diameter 30 cm. Wind is funnelled around the accommodation block giving eddies over the monkey island. The method of wind measurement is visual.
- Note 2 The screen is positioned on the aft port leg of the signal mast 1.3 m above the steel deck of the wheelhouse top, 15 m inboard and 23 m forward of the funnel. An intermittent exhaust fan is sited 4 m from the screen on the port side and natural vents from the wheelhouse are sited 12 m from the screen on both the port and starboard sides. Thermometers are electric resistance.

The Atlantic Conveyor has made 809 observations in the North Atlantic between 54°N and 37°N

ATLANTIC CONVEYOR - CALLSIGN GZMM

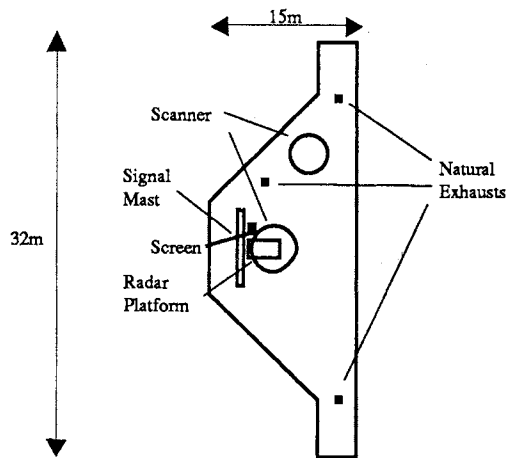
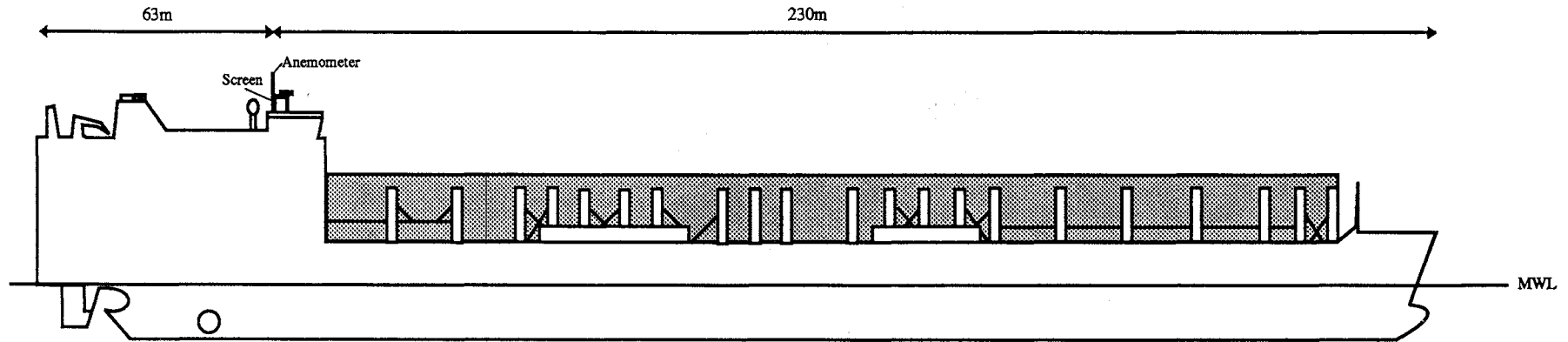

Plan of Wheelhouse Top

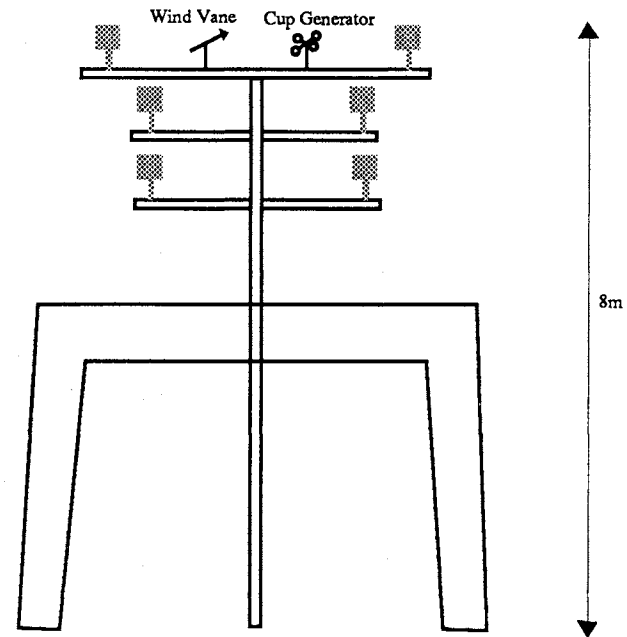

View of signal mast from forward

NICKERIE - CALLSIGN VRAZ

Length: 108 m
 Breadth: 16 m
 Draft: 6 m
 Type: Banana Ship
 Recruiting Country: Britain
 Reference Level: 13±4 m asl

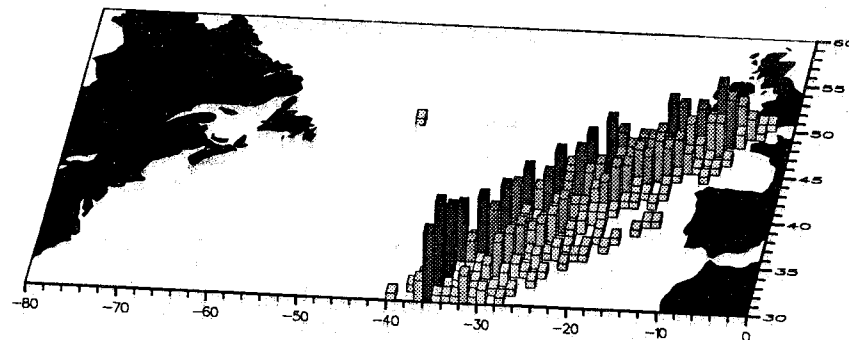
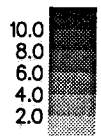

Instrument	Location	Instrument Type	Height ASL (m)	Height Above Deck (m)	Exposure				See Note
					315- 045	045- 135	135- 225	225- 315	
Anemometer	Starboard mainmast gardarm	Propeller vane - Seiki, Japan	24	10	9	9	9	4	1
Port Screen	5 m above bulwark	Marine Screen	12	0.7	4	1	6	8	2
Starboard Screen	5 m above bulwark	Marine Screen	12	0.7	4	8	6	1	2
Psychrometer	Not fitted								
Aneroid Barometer	Chartroom	Barograph, PAB	13	1.5					
SST	Bucket	Rubber							3

- Note 1 The anemometer is well exposed but the method of wind measurement is visual
- Note 2 Screens are lashed to open metal rails 70 cm above a steel deck with rubber matting and 1.5 m from the ship's side. Both are sheltered to the front by a solid metal bulwark with a wind deflector. Thermometers are mercury
- Note 3 The bucket is lowered from the leeward side the the Bridge Wing

The Nickerie has made 553 observations in the North Atlantic between 50°N and 30°N

M.V. NICKERIE - CALLSIGN VRAZ

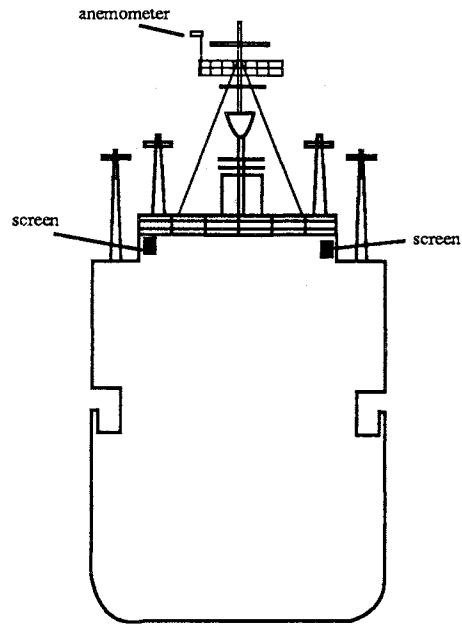
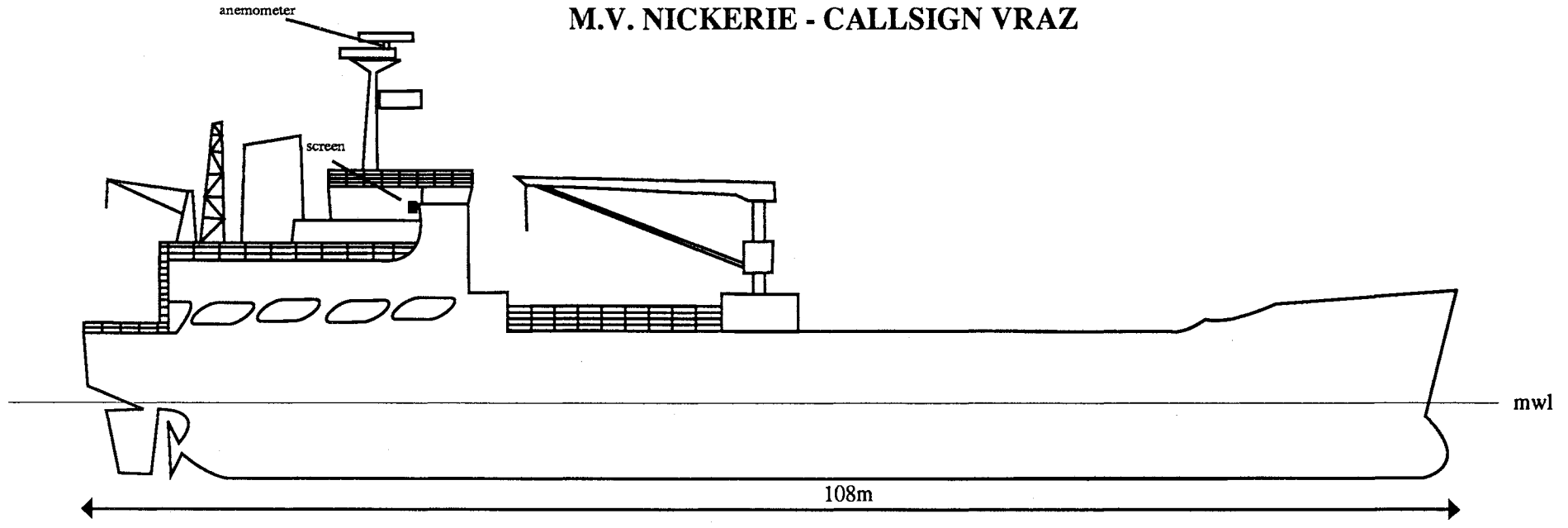

Midship - Front View

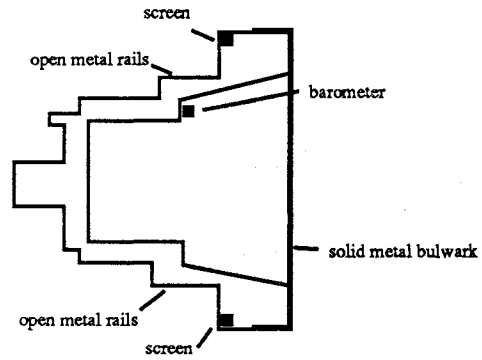

Navigation Bridge Deck

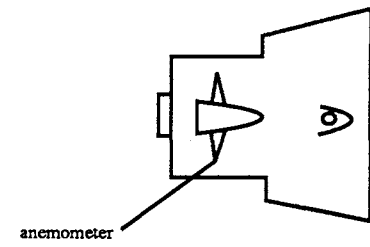

Compass Bridge Deck

CANMAR AMBASSADOR - CALLSIGN VSBV3

Length: 231.5 m
 Breadth: 30.6 m
 Draft: 10.6 m
 Type: Container
 Recruiting Country: Britain
 Reference Level: 21±0.5 m asl

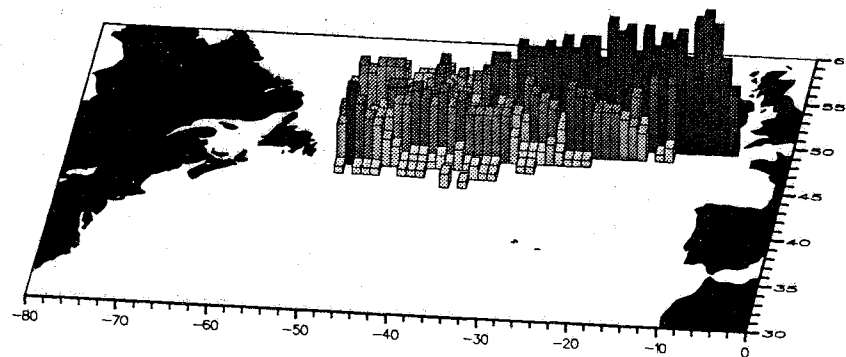
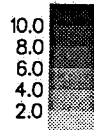

Instrument	Location	Instrument Type	Height ASL (m)	Height Above Deck (m)	Exposure				See Note
					315-045	045-135	135-225	225-315	
Anemometer	Mast on wheelhouse	Munroe	30	10	6	5	9	9	1
Port Screen	Bridge Wing	Marine Screen	25	1	1	5	7	9	2
Starboard Screen	Bridge Wing	Marine Screen	25	1	1	9	7	5	2
Psychrometer	Not fitted								
Aneroid Barometer	Wheelhouse	Barograph, PAB	25						
SST	Bucket	Rubber							
ASAP									

Note 1 The method of wind measurement is visual

Note 2 The screens are positioned on a walkway behind the Bridge. They are 4 m inboard and clear of the superstructure. Thermometers are mercury

The Canmar Ambassador has made 1377 observations in the North Atlantic between 54°N and 44°N

CANMAR AMBASSADOR - CALLSIGN VSBV3

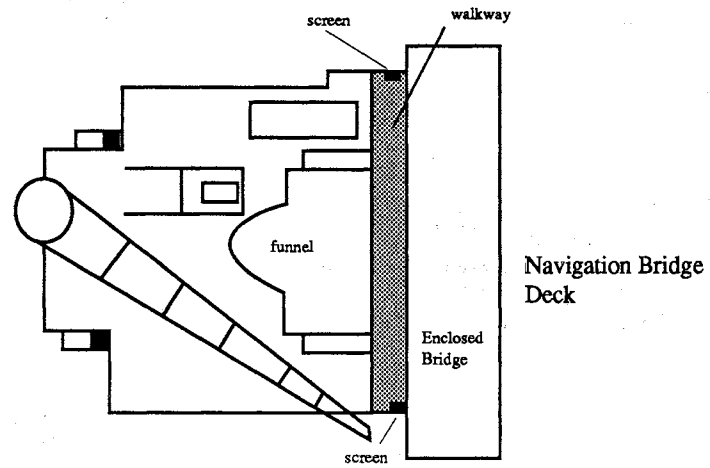
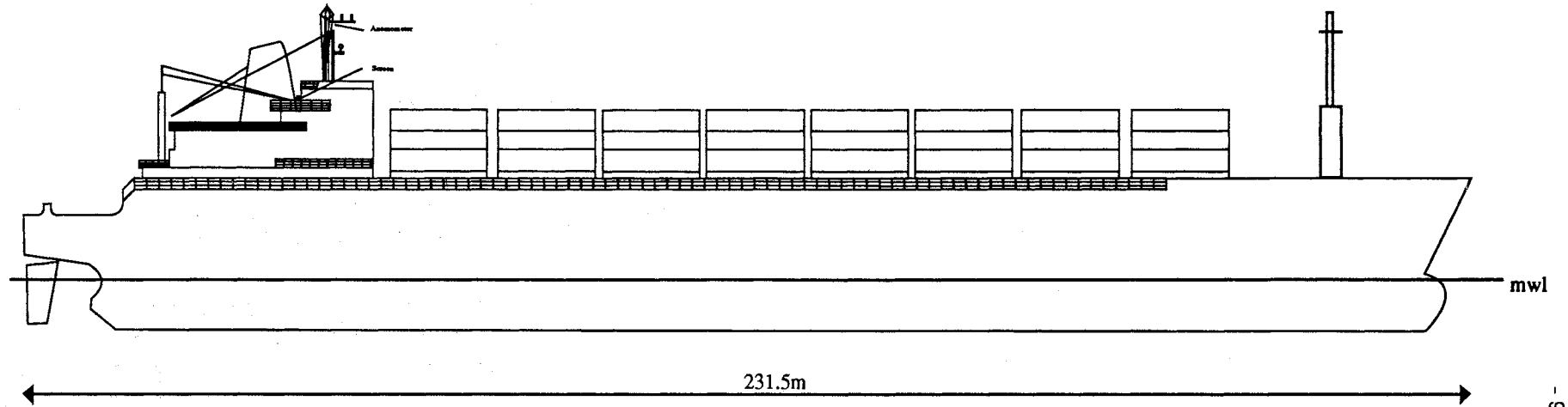

AMERICANA - CALLSIGN IBPA

Length: 208 m
 Breadth: 30.6 m
 Draft: 10.4 m
 Type: Ro - Ro / Container
 Recruiting Country: USA
 Reference Level: 24 m asl

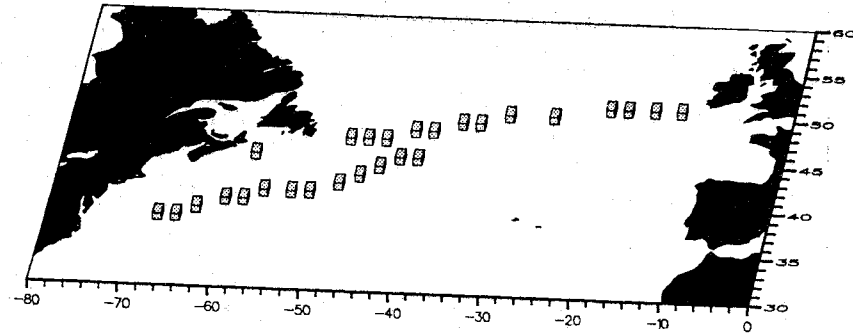
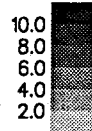

Instrument	Location	Instrument Type	Height ASL (m)	Height Above Deck (m)	Exposure				See Note
					315-045	045-135	135-225	225-315	
Anemometer	Not fitted								1
Port Screen	Bridge Wing		24	1.7					2
Starboard Screen	Bridge Wing		24	1.7					2
Psychrometer	Not fitted								
Barometer	Chartroom		24	1.0					
SST	Engine room intake		-5						

Note 1 Method of wind measurement is visual

Note 2 Screens are small and are made of white plastic. Screens are sheltered by the wheelhouse and a wind deflector to the front.

The Americana has made 34 observations in the North Atlantic

AMERICANA - CALLSIGN IBPA

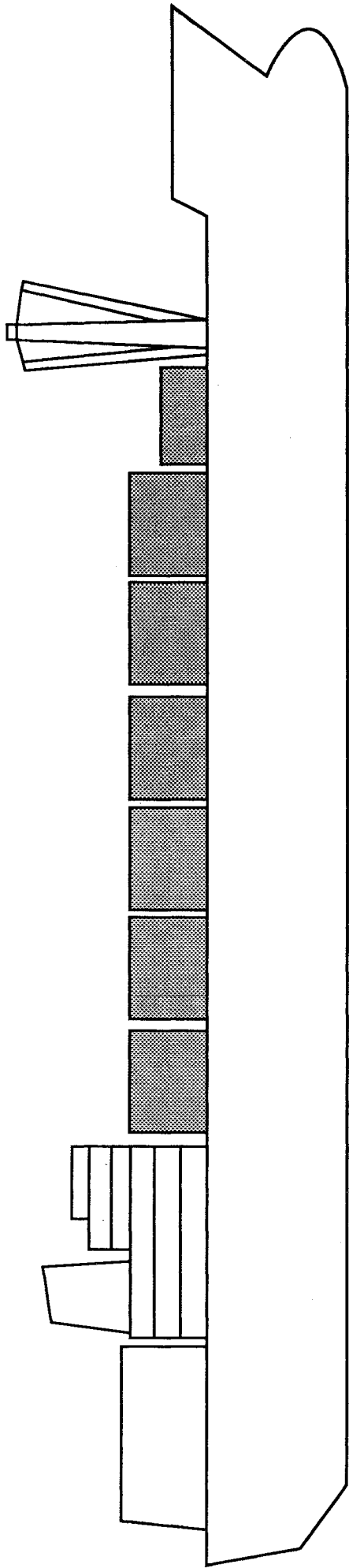

208 m

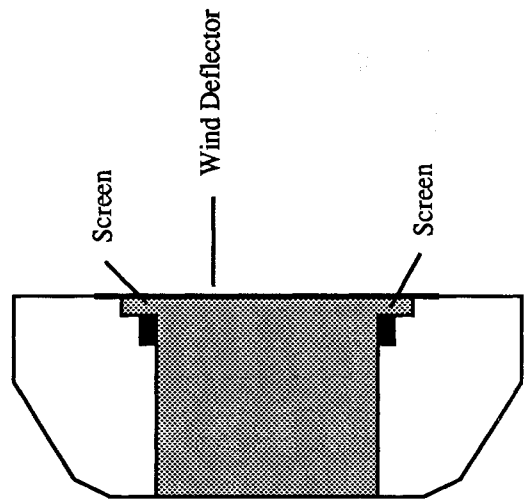

SEALAND ATLANTIC - CALLSIGN KRLZ

Length: 290 m
 Breadth: 32 m
 Draft: 12 m
 Type: Container Ship
 Recruiting Country: USA
 Reference Level: 31±0.5 m asl

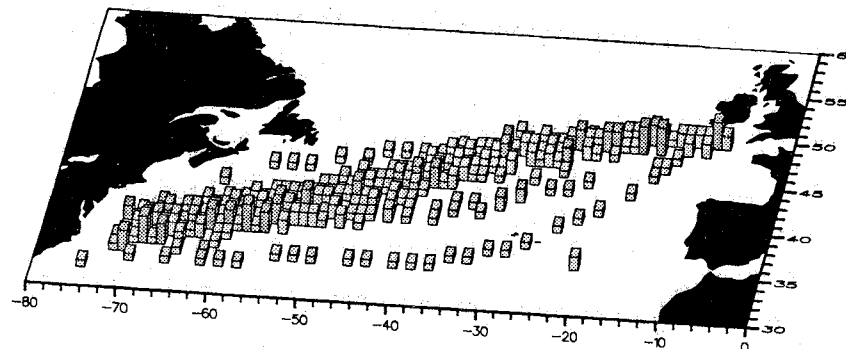
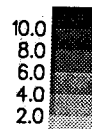

Instrument	Location	Instrument Type	Height ASL (m)	Height Above Deck (m)	Exposure				See Note
					315-045	045-135	135-225	225-315	
Anemometer	Pole on port of bridge deck		~38	6.4					
Port Screen	Shelter on bridge deck		~32	~1.5					1
Starboard Screen	Shelter on bridge deck		~32	~1.5					1
Psychrometer	Not fitted								
Barometer	Chartroom		~32	~1.8					
SST	Bucket								
SST	Engine room intake		~ -8						

Note 1 Thermometers are mercury

The Sealand Atlantic has made 415 observations in the North Atlantic between 31°N and 50°N

SEALAND ATLANTIC - CALLSIGN KRLZ

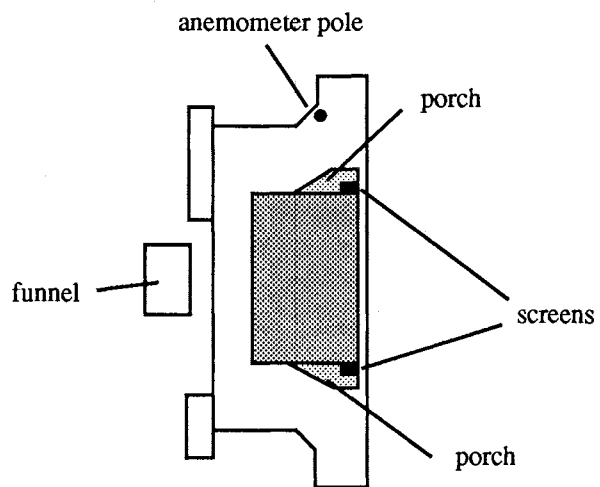
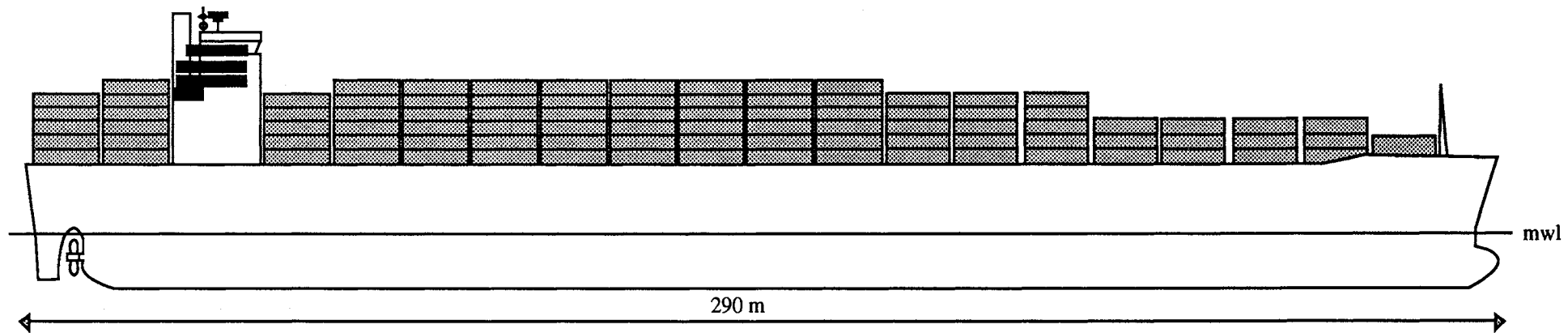

JULIUS HAMMER - CALLSIGN KRGJ

Length: 207 m
 Breadth: 27 m
 Draft: 10 m
 Type: Tanker
 Recruiting Country: USA
 Reference Level: 15±4 m asl

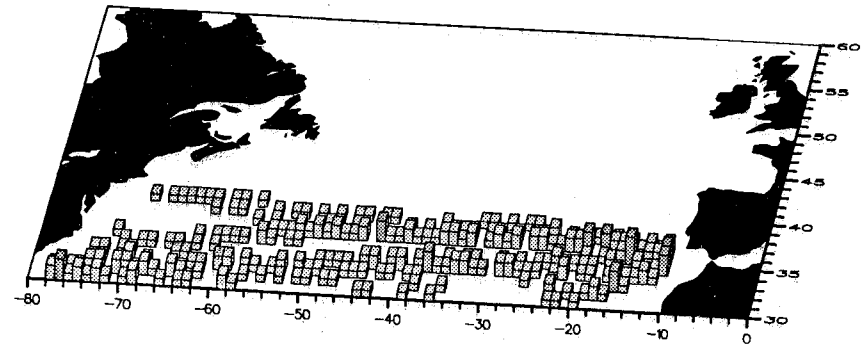
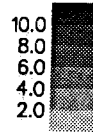

Instrument	Location	Instrument Type	Height ASL (m)	Height Above Deck (m)	Exposure				See Note
					315-045	045-135	135-225	225-315	
Anemometer	Not fitted								1
Port Screen	Not fitted								
Starboard Screen	In shelter on Bridge Wing	Taylor Instruments	27.5	1.8	4	8	1	0	2
Psychrometer	Not fitted								
Aneroid Barometer	Wheelhouse	NWS Marine Barometer, Belfort Instrument Company	27.5	1.8					
SST	Engine room intake		-5						

Note 1 The method of wind measurement is visual

Note 2 The white wood screen is located on the starboard side of the exterior bulkhead of the wheelhouse. Thermometers are mercury

The Julius Hammer has made 349 observations in the North Atlantic between 30°N and 43°N

JULIUS HAMMER - CALLSIGN KRGJ

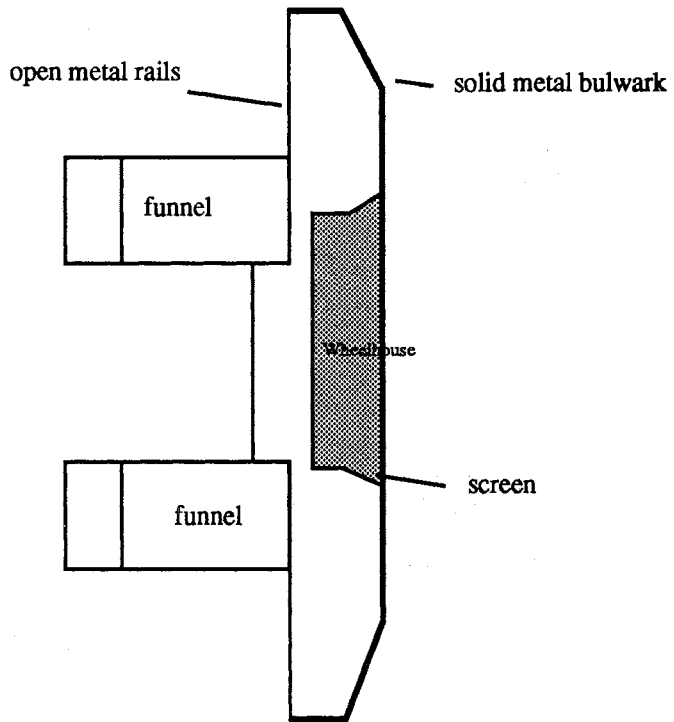
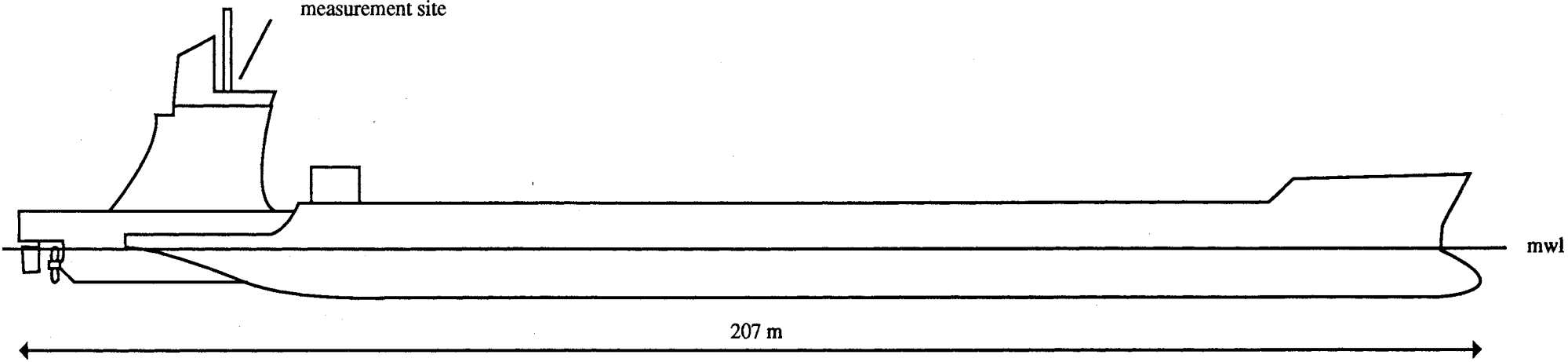

MARGARET LYKES - CALLSIGN KRJL

Length: 202 m
 Breadth: 25 m
 Draft: 8 m
 Type: Container Ship
 Recruiting Country: USA
 Reference Level: 15±1 m asl

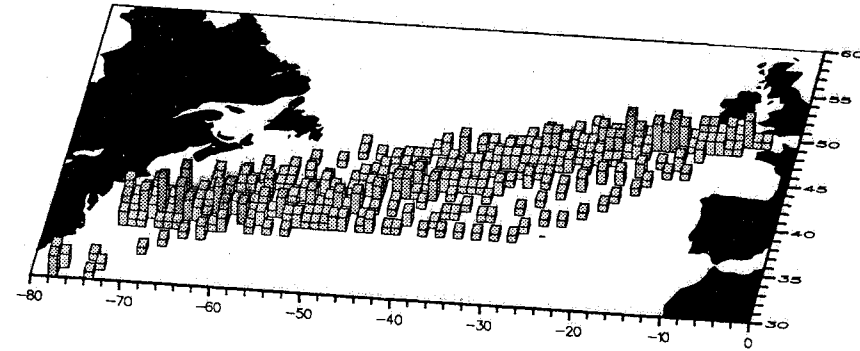
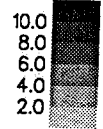

Instrument	Location	Instrument Type	Height ASL (m)	Height Above Deck (m)	Exposure				See Note
					315-045	045-135	135-225	225-315	
Anemometer	Not fitted								1
Port Screen	Porch on Bridge Wing	Taylor Thermometers	28		3	7	4	7	2
Starboard Screen	Porch on Bridge Wing	Taylor Thermometers							
Psychrometer	Not fitted								
Aneroid Barometer	Chartroom	Barometer, National Weather Service Barograph, Bendix Friez	28						
SST	Engine room intake		-7						

Note 1 Method of wind measurement is visual

Note 2 Screens are located in the 'porches' of the Bridge Wings and are made of white wood (starboard screen has brown wood inside). Screens are fitted to the side of the wheelhouse above the level of the solid metal bulwark which surrounds the Bridge Wing. Thermometers are mercury.

The Margaret Lykes has made 539 observations in the North Atlantic between 30°N and 50°N

MARGARET LYKES - CALLSIGN KRJL

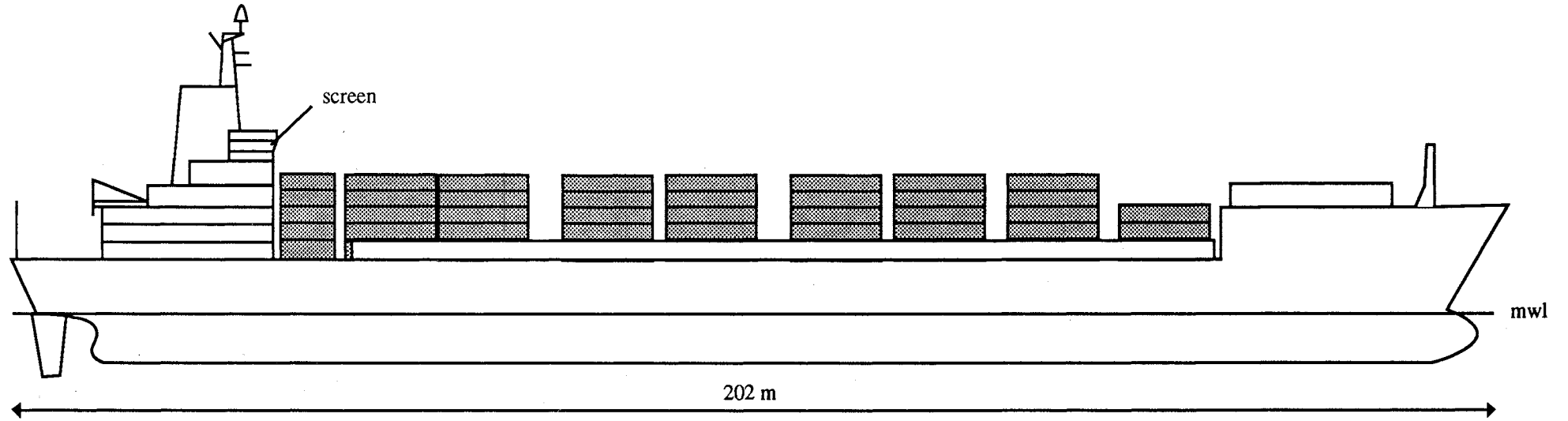

- 105 -

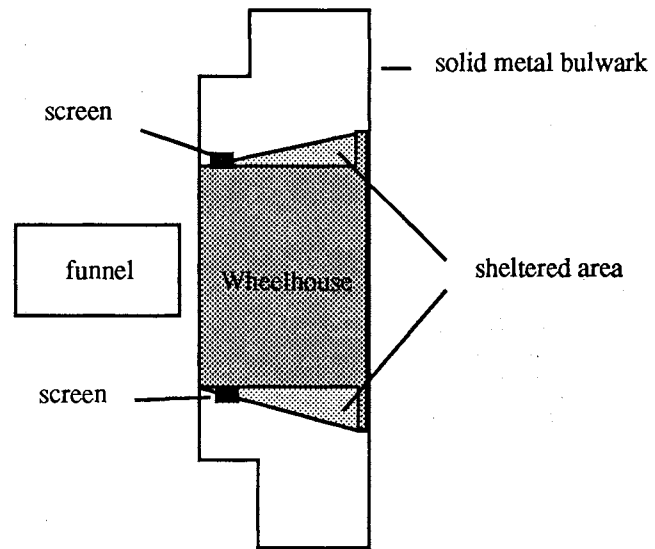

SHELDON LYKES - CALLSIGN KRJP

Length: 202 m
 Breadth: 25 m
 Draft: 8 m
 Type: Container Ship
 Recruiting Country: USA
 Reference Level: 22 ± 2 m asl

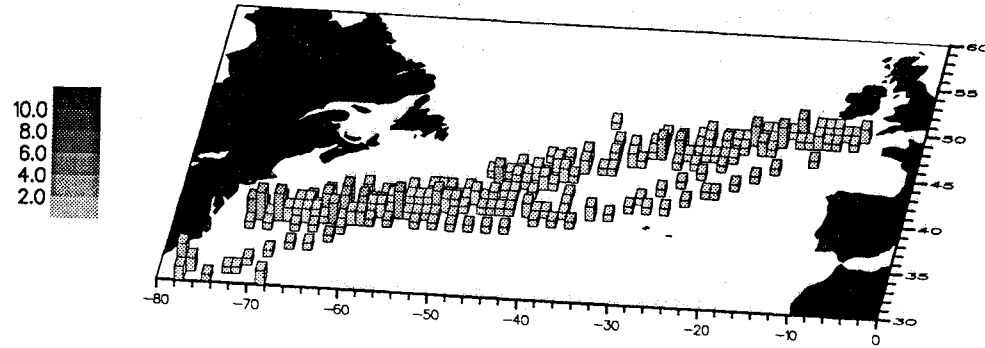

Instrument	Location	Instrument Type	Height ASL (m)	Height Above Deck (m)	Exposure				See Note
					315-045	045-135	135-225	225-315	
Anemometer	Not fitted								1
Port Screen	Porch on Bridge Wing	Taylor Thermometers	22	1.5					2
Starboard Screen	Porch on Bridge Wing	Taylor Thermometers	22	1.6					2
Psychrometer	Not fitted								
Barometer	Chartroom	United States Weather Bureau	22	1.7					
SST	Engine room intake		-7						

Note 1 The method of wind measurement is visual
 Note 2 The screens are made of brown wood and are shielded to the front

The Sheldon Lykes has made 299 observations in the North Atlantic between 30°N and 50°N

SHELDON LYKES - CALLSIGN KRJP

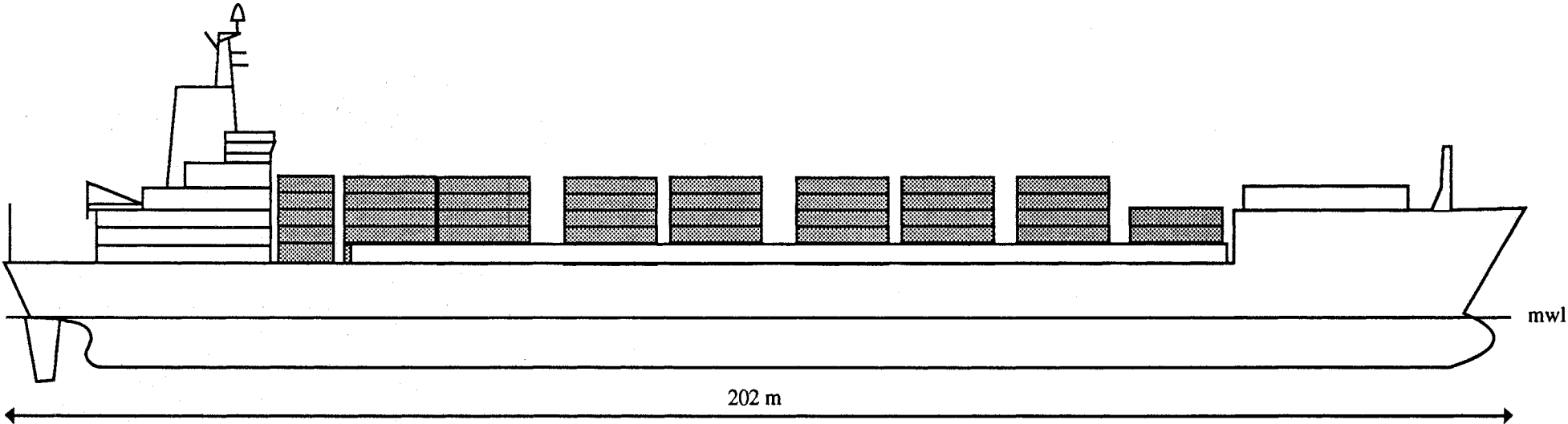

mwl

202 m

- 107 -

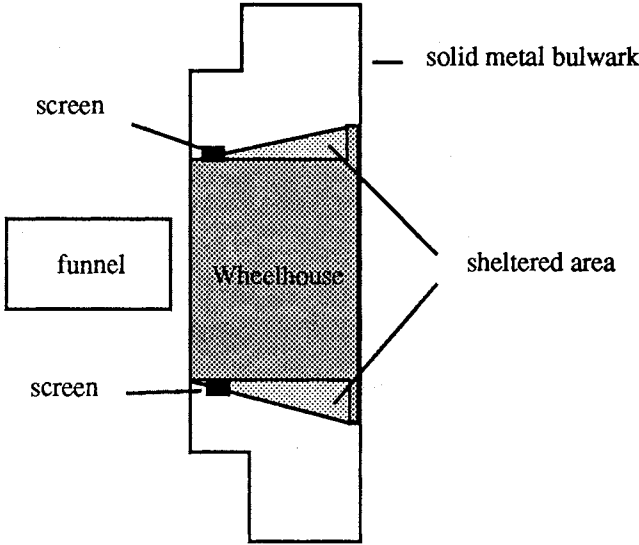

SEALAND COMMITMENT - CALLSIGN KRPB

Length: 290 m
 Breadth: 32 m
 Draft: 12 m
 Type: Container Ship
 Recruiting Country: USA
 Reference Level: 31±0.5 m asl

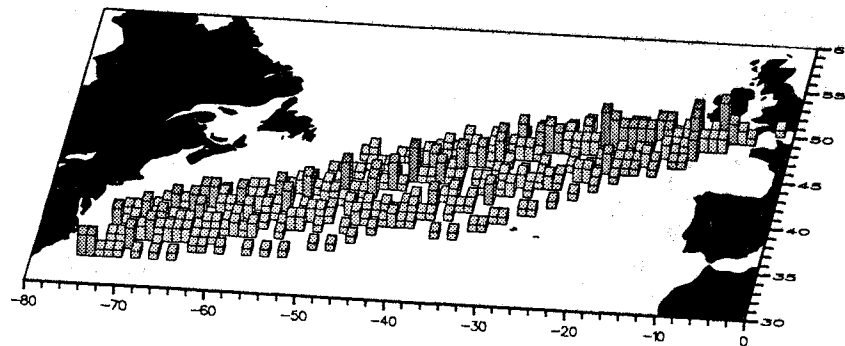
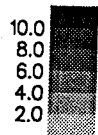

Instrument	Location	Instrument Type	Height ASL (m)	Height Above Deck (m)	Exposure				See Note
					315-045	045-135	135-225	225-315	
Anemometer	Mast on Bridge Deck		37.5	6.4					
Port Screen	Shelter by Wheelhouse		32.7	1.6					1
Starboard Screen	Shelter by Wheelhouse		32.7	1.6					1
Psychrometer	Not fitted								
Aneroid Barometer	Chartroom		33	1.8					
SST	Engine room intake		-7.8						

Note 1 Screening is grey metal and there is very little air movement in the box. Thermometers are electric resistance.

The Sealand Commitment has made 522 observations in the North Atlantic between 31°N and 50°N

SEALAND COMMITMENT- CALLSIGN KRPB

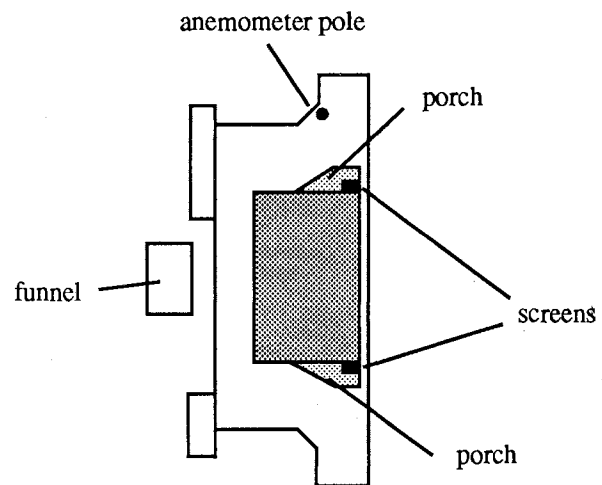
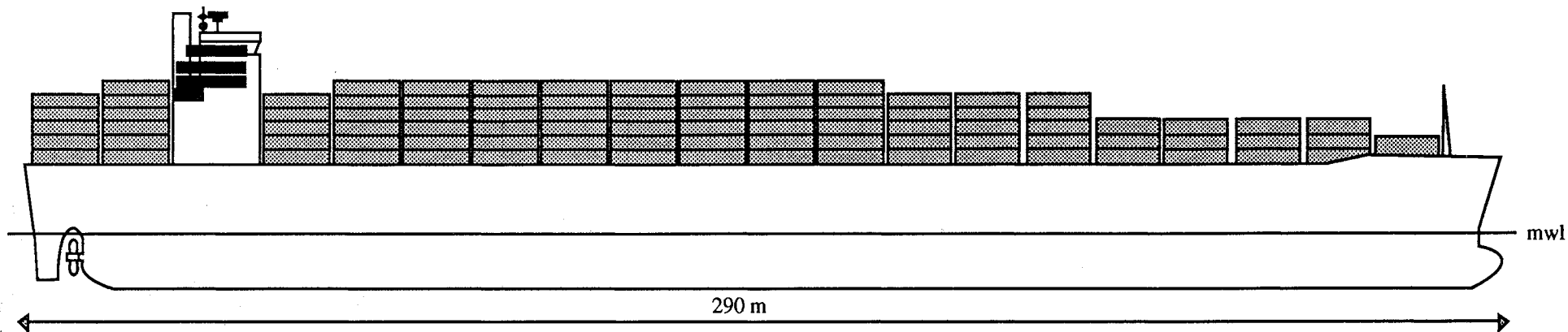

DELAWARE BAY - CALLSIGN WMLG

Length: 206 m
 Breadth: 32 m
 Draft: 11.5 m
 Type: Container
 Recruiting Country: USA
 Reference Level: 25 ± 1 m asl

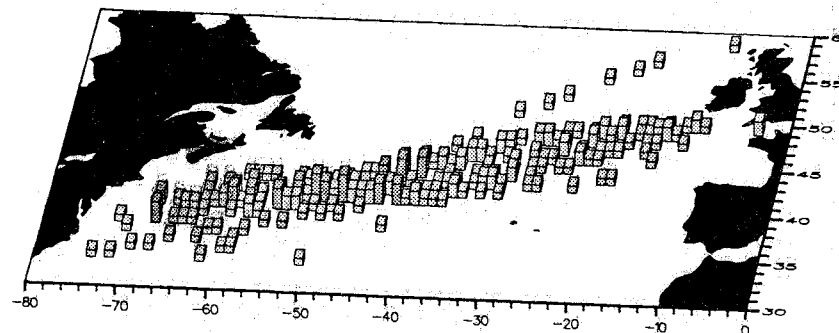
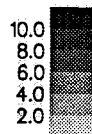

Instrument	Location	Instrument Type	Height ASL (m)	Height Above Deck (m)	Exposure				See Note
					315- 045	045- 135	135- 225	225- 315	
Anemometer	Antenna Mast	Unknown	36.6	9.1					1
Port Screen	Not fitted								
Starboard Screen	Below Rail (Bridge Deck?)	Unknown	27.4	.8					2
Psychrometer	Not fitted								
Barometer	Unknown	National Weather Service	27.4	1					
SST	Engine room intake		-9						

Note 1 Anemometer is not well exposed as there are many antennae in the same region.
 Note 2 Screen is fitted below the level of the rail and thermometers are in a white wooden box.

The Delaware Bay has made 276 observations in the North Atlantic between 32°N and 59°N

DELAWARE BAY - CALLSIGH WMLG

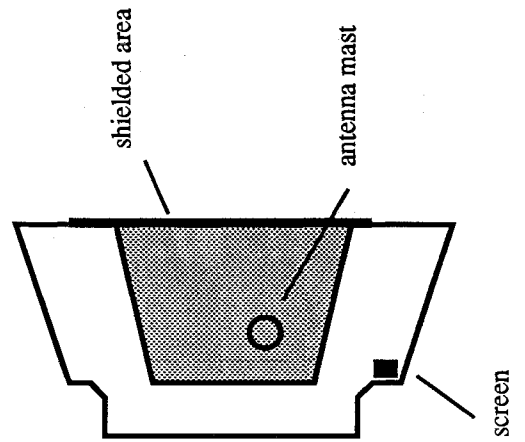
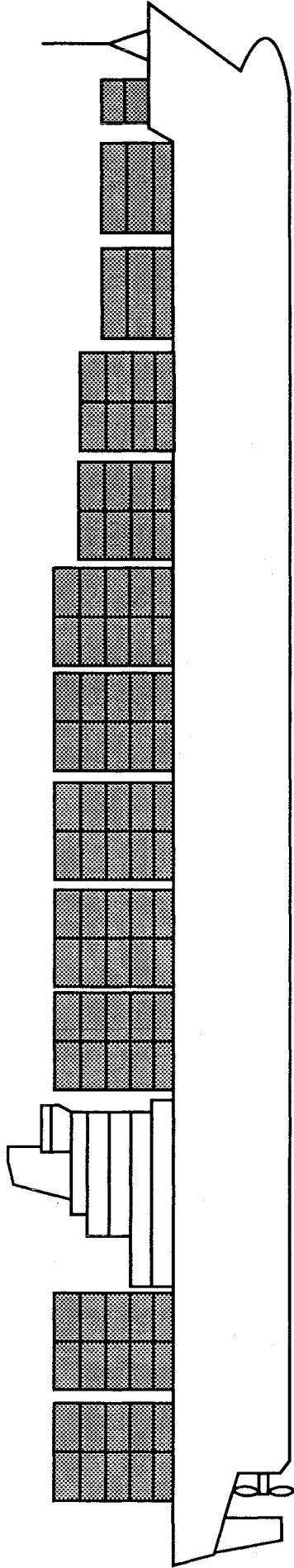

ADABELLE LYKES - CALLSIGN WPFZ

Length: 202 m
 Breadth: 25 m
 Draft: 8 m
 Type: Container Ship
 Recruiting Country: USA
 Reference Level: 22 m asl

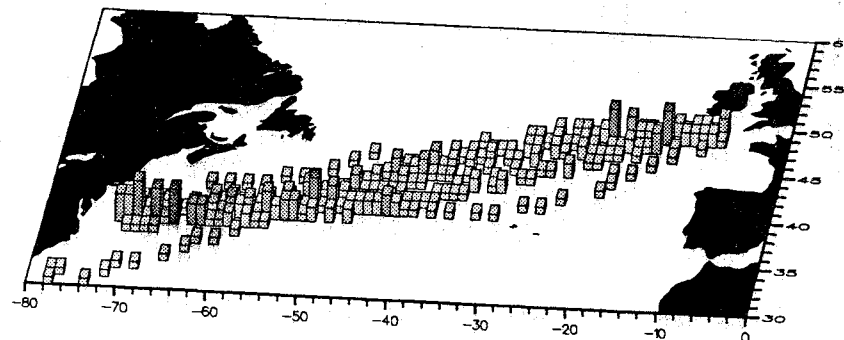
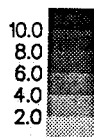

Instrument	Location	Instrument Type	Height ASL (m)	Height Above Deck (m)	Exposure				See Note
					315- 045	045- 135	135- 225	225- 315	
Anemometer	Not fitted								1
Port Screen	Porch on Bridge Wing	Weksler thermometers	37	1.4	0	3	4	3	2
Starboard Screen	Not fitted								
Psychrometer	Not fitted								
Barometer	Chartroom	Analogue, Weksler Instruments	37	1.4					
SST	Engine room intake		-6						

Note 1 Method of wind measurement is visual

Note 2 Screen is made of brown varnished wood and is located in the 'porch' of the Bridge Wing of the port side. It is fitted to the side of the wheelhouse above the level of the solid metal bulwark which surrounds the Bridge Wing

The Adabelle Lykes has made 359 observations in the North Atlantic between 30°N and 50°N

ADABELLE LYKES - CALLSIGN WPFZ

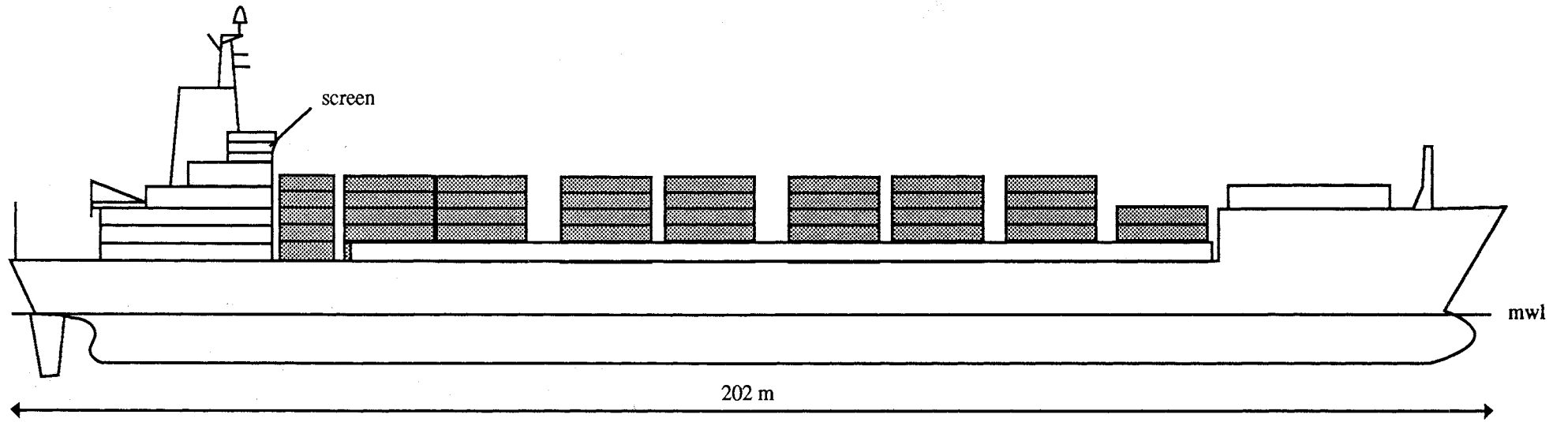

- 113 -

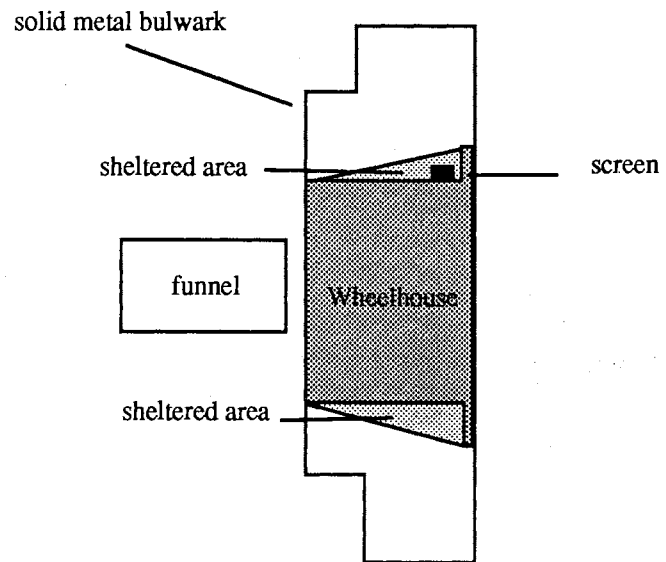

CHARLOTTE LYKES - CALLSIGN WPHZ

Length: 202 m
 Breadth: 25 m
 Draft: 8 m
 Type: Container Ship
 Recruiting Country: USA
 Reference Level: 20 ± 0.5 m asl

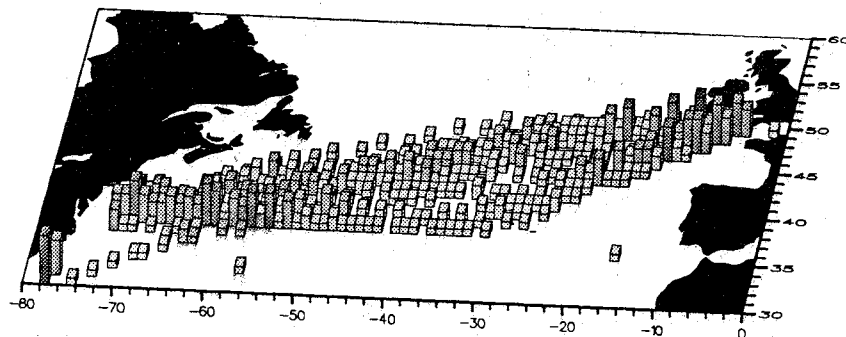
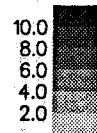

Instrument	Location	Instrument Type	Height ASL (m)	Height Above Deck (m)	Exposure				See Note
					315-045	045-135	135-225	225-315	
Anemometer	Not fitted								
Port Screen	Bridge Deck		24.4	1.2					1
Starboard Screen	Bridge Deck		24.4	1.2					1
Psychrometer	Not fitted								
Barometer	Unknown	National Weather Service Barometer	24.4	1.3					
SST	Engine room intake		-6						

Note 1 Port and starboard screens are shielded just behind the forward part of the bridge deck. Screens are brown varnished wood.

The Charlotte Lykes has made 709 observations in the North Atlantic between 30°N and 50°N

CHARLOTTE LYKES - CALLSIGN WPHZ

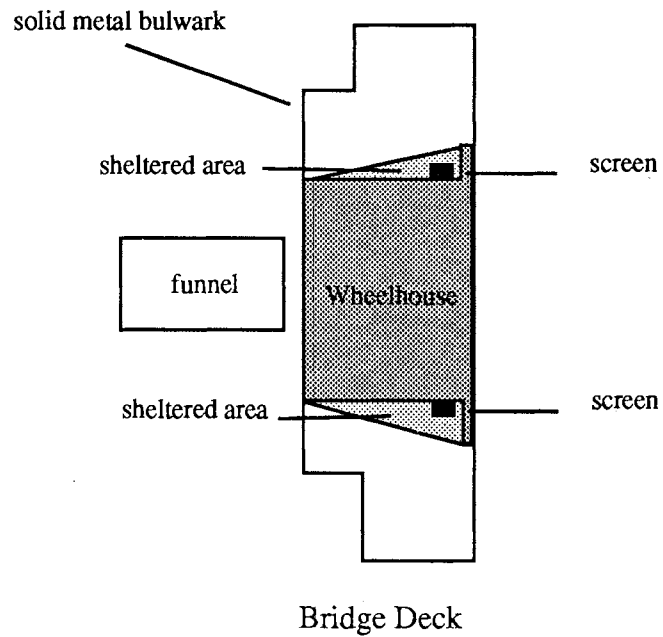
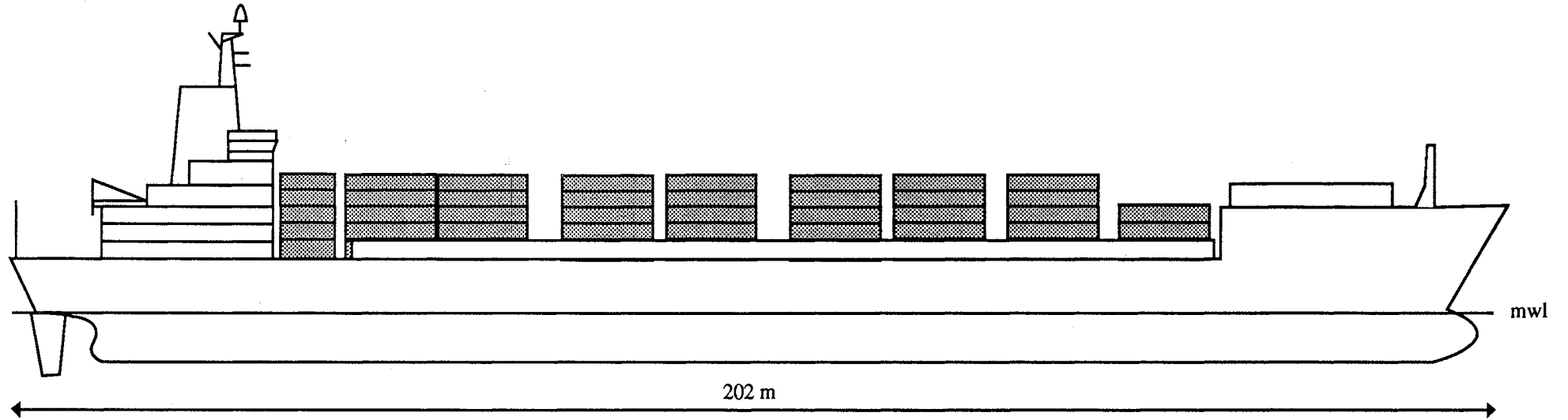

GALVESTON BAY - CALLSIGN WPVF

Length: 290 m
 Breadth: 32 m
 Draft: 12 m
 Type: Container Ship
 Recruiting Country: USA
 Reference Level: 31±0.5 m asl

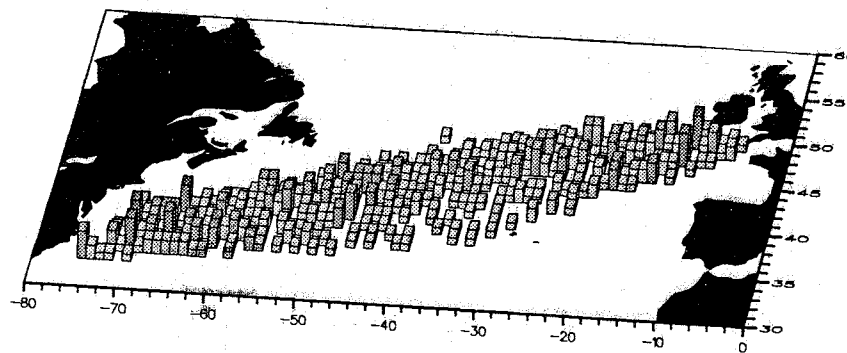
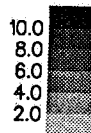

Instrument	Location	Instrument Type	Height ASL (m)	Height Above Deck (m)	Exposure				See Note
					315-045	045-135	135-225	225-315	
Anemometer	Mast on Bridge Deck	Seiki F235	37.5	6.4	9	9	9	9	1
Port Screen	Bridge Deck	Murmberg Thermometers	32.7	1.6	1	0	0	7	2
Starboard Screen	Bridge Deck	Murmberg Thermometers	32.7	1.6	1	7	0	0	2
Psychrometer	Not fitted								
Aneroid Barometer	Chartroom	Barograph, USWB G101	33	1.9					
SST	Engine room intake		-7.8						

Note 1 Anemometer appears to be well exposed but the pole is of similar height to the sensor which may affect the reading.
 Note 2 Rating exaggerates exposure?. Screens are grey metal and thermometers are mercury.

The Galveston Bay has made 609 observations in the North Atlantic between 31°N and 50°N

GALVESTON BAY- CALLSIGN WPVF

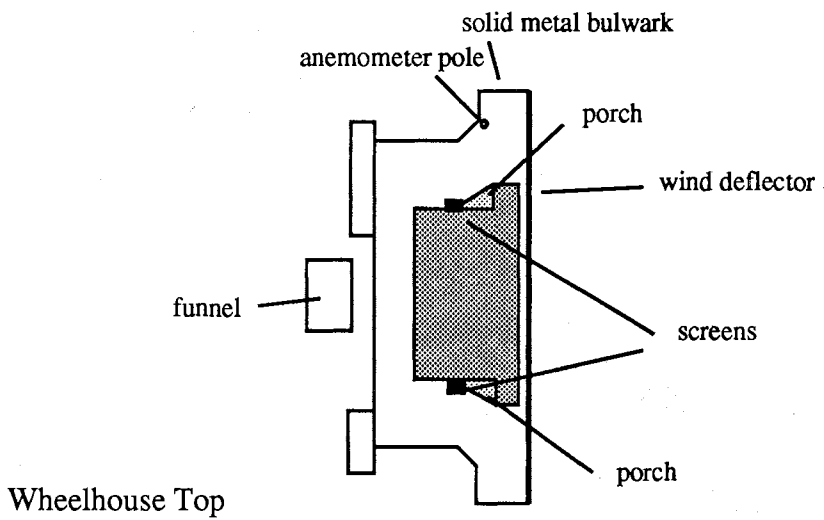
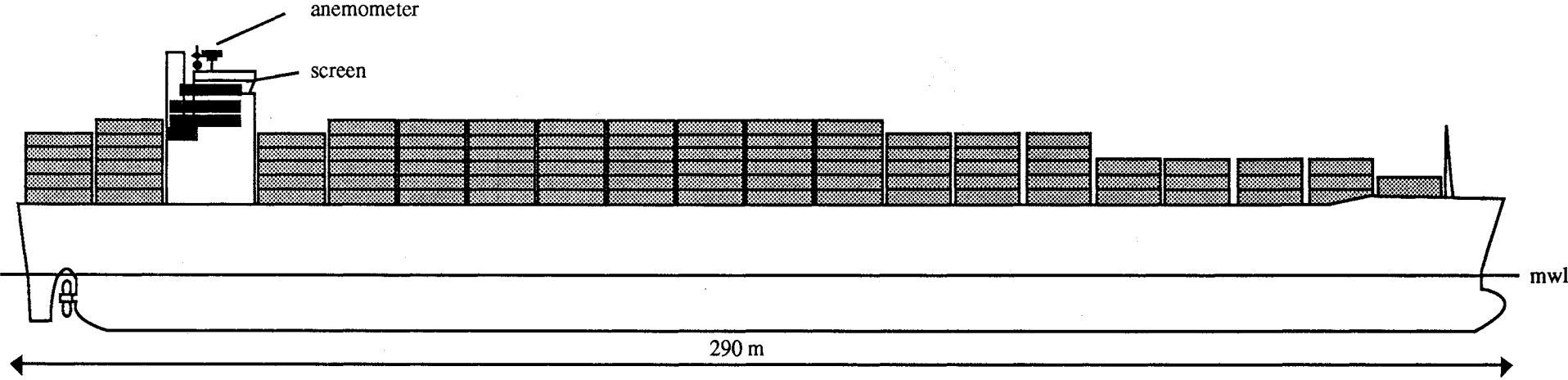

NEDLLOYD HUDSON - CALLSIGN WPWH

Length: 290 m
 Breadth: 32 m
 Draft: 12 m
 Type: Container Ship
 Recruiting Country: USA
 Reference Level: 32±0.5 m asl

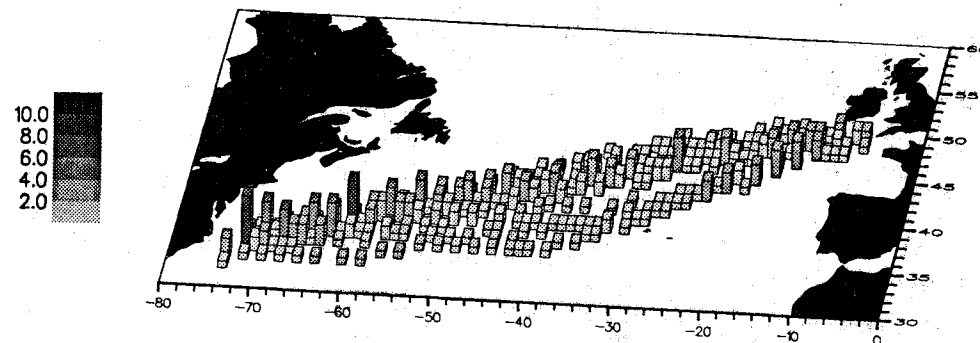

Instrument	Location	Instrument Type	Height ASL (m)	Height Above Deck (m)	Exposure				See Note
					315-045	045-135	135-225	225-315	
Anemometer	Mast on Bridge Deck	Seiki F235	38.1	6.4	9	9	9	9	1
Port Screen	Bridge Deck	Murmberg Thermometers	31.7	1.7	1	0	0	7	2
Starboard Screen	Bridge Deck	Murmberg Thermometers	31.7	1.7	1	7	0	0	2
Psychrometer	Not fitted								
Aneroid Barometer	Chartroom	Analogue, USWB G101	31.7	1.7					
SST	Engine room intake		-7.8						

Note 1 Anemometer appears to be well exposed

Note 2 Rating exaggerates exposure?. Screen is chrome metal, thermometers are mercury

The Nedlloyd Hudson has made 427 observations in the North Atlantic between 32°N and 50°N

NEDLLOYD HUDSON - CALLSIGN WPWH

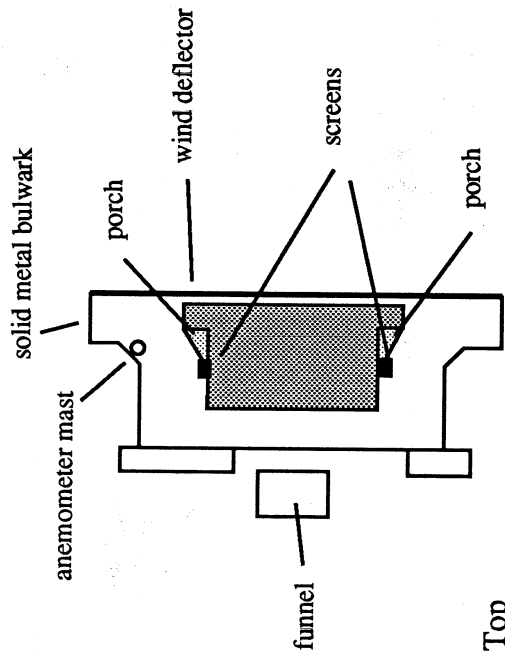
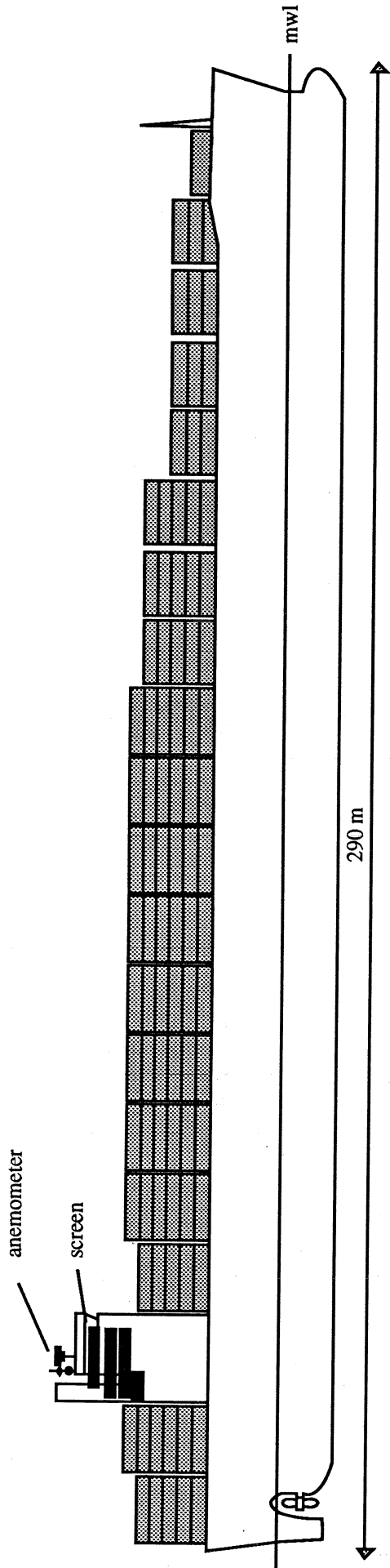

Wheelhouse Top

LYRA - CALLSIGN WSDG

Length: 193 m
 Breadth: 27 m
 Draft: 9 m
 Type: Container Ship
 Recruiting Country: USA
 Reference Level: 0 m asl

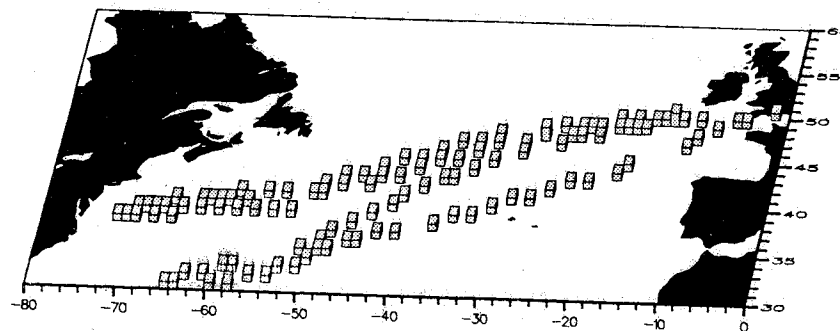
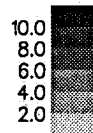

Instrument	Location	Instrument Type	Height ASL (m)	Height Above Deck (m)	Exposure				See Note
					315-045	045-135	135-225	225-315	
Anemometer	On mast	Thomas Walker	29	2	9	9	9	9	
Port Screen	In shelter on Bridge Wing	Taylor	27	1	0	0	3	3	1
Starboard Screen	In shelter on Bridge Wing	Taylor	27	1	0	3	3	0	1
Psychrometer	Not fitted								
Aneroid Barometer	Wheelhouse	Barograph, USWB	27.4	~1.8					
SST	Engine room intake		-6.4						2

Note 1 The wooden screens are located inside the Bridge Wing 'porch'. Thermometers are mercury
 Note 2 Inlet temperatures are cross checked with another thermometer at the pump

The Lyra has made 124 observations in the North Atlantic between 30°N and 50°N

LYRA - CALLSIGN WSDG

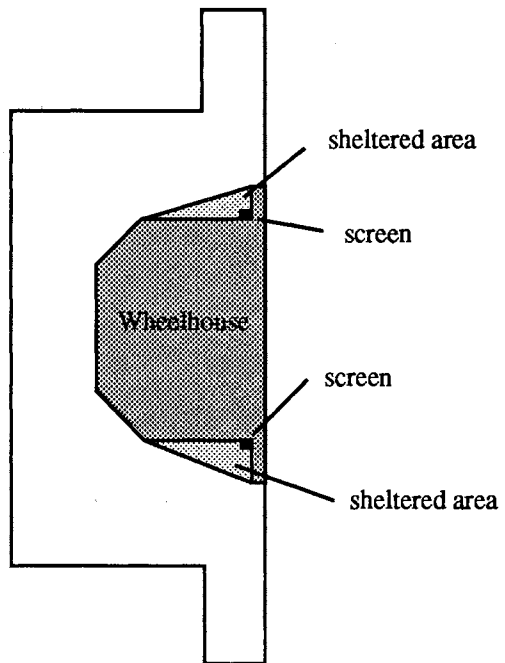
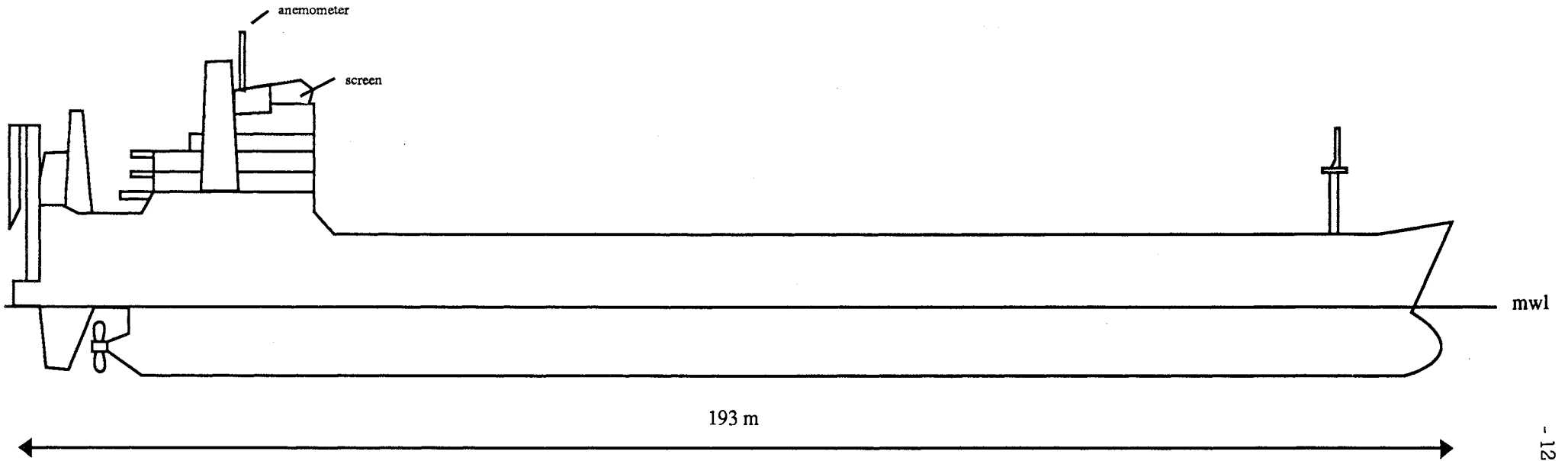

Wheelhouse Top

APPENDIX 1 HULL SENSOR SPECIFICATIONS

In view of the recommendation that hull sensors should be fitted to Voluntary Observing Ships whenever possible, details of hull sensors used by the United Kingdom and the Netherlands Meteorological Services are given in this appendix.

A1. United Kingdom hull-mounting sea-temperature sensor Mk. 2

A platinum resistance element, wound in the form of a thin plate (A in Figure A1a), is fitted behind and in close contact with a copper plate let into a disc of synthetic resin-bonded fibre, B. The disc is fitted inside a ring C, either of resin-bonded fibre fixed with adhesive to the inside of the ship's hull below the water-line, or of stainless steel welded to the ship's hull. The mounting position needs to be as free as possible from curvature to allow maximum contact between the hull and the copper plate. The output from the element is fed to a manually balanced bridge indicator or an automatic digital temperature indicator.

A2. Netherlands hull-contact sensor PT100

The sensor is fitted within a seamless steel pipe fitted to the ship's hull. Isolating glass fibre is packed around the sensor and a plastic lid then covers the instrument. The sensor is shown in Figure A1b

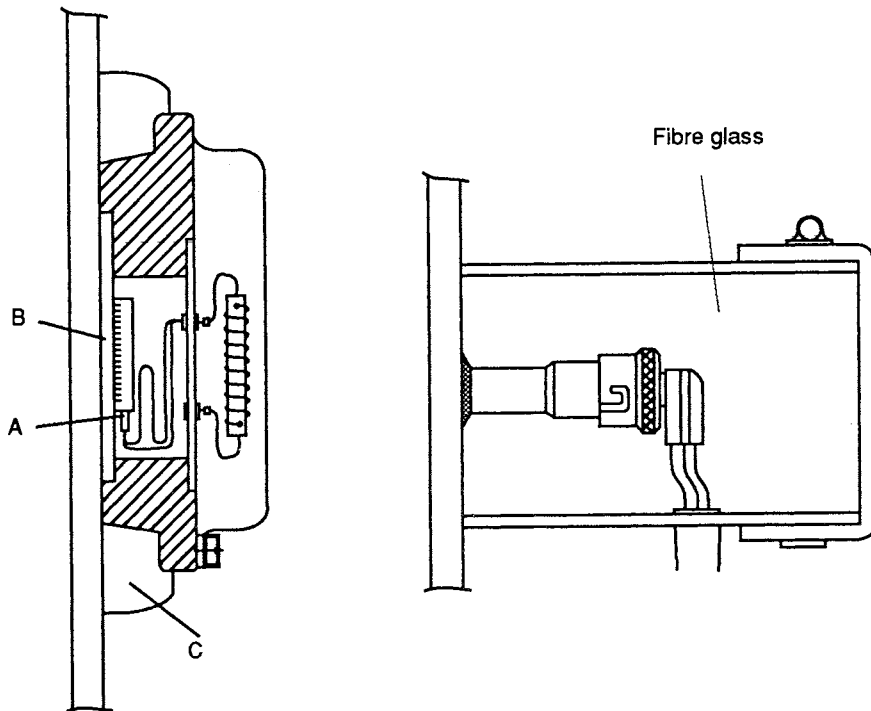

Figure A1 UK Hull Contact Sensor (a)

Netherlands Hull Contact Sensor (b)