



A review of the culture potential of *Solea solea* and *S. senegalensis*

A.K. Imsland¹, A. Foss², L.E.C. Conceição³, M.T. Dinis³, D. Delbare⁴, E. Schram⁵,
A. Kamstra⁵, P. Rema⁶ & P. White²

¹Akvaplan-niva, Iceland Office, Akralind 4, 201 Kópavogi, Iceland (Phone: +354-562-5800; Fax: +354-564-5801; E-mail: albert.imsland@akvaplan.niva.no); ²Akvaplan-niva, Polar Environmental Centre, 9296 Tromsø, Norway; ³CCMAR, Universidade do Algarve, Campus de Gambelas, 8000-810 Faro, Portugal; ⁴Centre for Agricultural Research, Burgenmeester Van Gansberghelaan 96, 9820 Merelbeke, Belgium; ⁵Netherlands Institute for Fisheries Research, Haringkade 1, 1970 AB IJmuiden, The Netherlands; ⁶CIMAR, UTAD, Dept. Zootechn., Vila Real, Portugal

Accepted 24 May 2004

Contents

Abstract	page 379
Introduction	380
Aspects of natural biology of sole	381
Migration of sole	
Population genetics of sole	
Population separation and growth differences	
Environmental conditions – broodstock	384
Broodstock and treatment of <i>S. solea</i>	
Broodstock and treatment of <i>S. senegalensis</i>	
Hormonally induced spawning and stripping of eggs	
Production of larvae and juveniles	387
<i>S. solea</i>	
<i>S. senegalensis</i>	
Juvenile ongrowing	392
Ongrowing of <i>S. solea</i>	
Ongrowing of <i>S. senegalensis</i>	
Diseases	397
<i>S. solea</i>	
<i>S. senegalensis</i>	
Culture systems	399
Farming in recirculation systems – cost analysis	
Earthen ponds	
Shallow raceways	
Water quality aspects in intensive sole rearing	
Conclusions	402
Acknowledgements	403
References	403

Key words: aquaculture, biology, ecology, population genetics, *Solea senegalensis*, *Solea solea*

Abstract

A number of scientific studies have investigated aspects of soles (*Solea solea* and *S. senegalensis*) ecology, population genetics and biology in their natural environment, and the species have been extensively studied in captivity during the last decade. Studies on the genetic population structure of sole indicate that several distinct breeding populations exist within its distributional range in European waters. Recent studies

suggest a phylogenetic relatedness of *S. solea* and *S. senegalensis*, being found as closest sister lineages in most reconstructions. However, studies on molecular genetics and morphological traits give diagnostic differences that consistently lead to their taxonomic separation at the specific rank. Studies show that sole spawn readily in captivity, and the buoyant, fertilized eggs are easily collected. Stocking density during maturation should be 1–1.5 kg/m², and temperature should be kept above 16 °C (*S. senegalensis*) or between 8 and 12 °C (*S. solea*). In nature, the onset of spawning is related to a rise in temperature occurring during spring (March–June). Salinity should be kept constant around 33–35‰ and the fish reared under simulated natural photoperiod (LDN). In other cultured flatfish species, a change in the photoperiod is the key environmental signal used to manipulate and control maturation, but at present time there are no published work that verifies or contradicts this for either *S. senegalensis* or *S. solea*. Studies indicate that a mixture of inert and live food may increase the weaning success of sole fry, and this can be further enhanced by using attractants in the dry feed. Future experiments are needed to determine the ideal time to commence weaning and determine the minimum duration of this period. Studies on alternative feeding strategies are also required. The effect of temperature and photoperiod on juvenile growth has not been studied systematically in neither of the two species and the relative importance of a direct photoperiod effect on growth in sole therefore remains to be defined.

Introduction

The aquaculture industry has expanded extensively in Europe in the last few decades, but this growth can mainly be attributed to the culture of a few marine species which already show signs of market saturation. Scientific and technical interests have focused on high value native species whose biological cycle can be reproduced using currently available breeding techniques. From this point of view, sole (*Solea solea*, Linnaeus, 1758 and *Solea senegalensis* Kaup, 1858) appear as credible candidates for marine culture. The current market price in the EU is around 8.5–16.5 €/kg depending on size and season for *S. solea* and around 8–14 €/kg for *S. senegalensis*. Currently, fisheries provide consumer demands for both species. In 1998 the total landing of sole in Europe was 45.586 tonnes (Anonymous, 1999). Annual catches fluctuate as a result of differences in year class strength, and it is hard to predict how sole landings will develop on the long term. However, considering the discussion on the sustainability of the fisheries and increasing pressure to close down fishing in parts of the North Sea (producing approx. 50% of the total landing for *S. solea*), it is obvious that landings are more likely to decrease than increase. The little information that can be found regarding wild catches of *S. senegalensis* indicate that catches are declining for this species (Anonymous, 1999, 2004).

Thirty years ago, sole was already considered one of the most interesting and promising species

for marine fish farming in Europe (Howell, 1997). The species did, however, never become a commercial success, as technological and disease problems hampered the development of commercial sole culture. The main problem was the occurrence of a disease called Black Patch Necrosis (BPN) (Bernadet et al., 1990). It is now known that poor nutrition in the natural diets fed to the sole contributed to BPN (Baynes and Howell, 1993). Another restraint of sole farming in Western and Northern Europe used to be water temperature control. Even the more northern of the two species (*S. solea*) requires relatively warm water (~20 °C) for optimal growth in the juvenile and on-growing stage. As a result, suitable artificial rearing sites (e.g., near power plants) were rare. Today recirculation technology is fully established and freely available. This means that optimal growth conditions for sole can be realized year-round even in temperate areas. This together with recent advances in feed technology, surrounding weaning and on-growing, have fuelled a renewed interest in sole as an aquaculture species (Howell, 1997; Dinis et al., 1999). A considerable number of scientific reports have been published over the last three decades, and several experiments have been conducted at laboratory and pilot scales in recent years. These reports and experiments have provided new and useful knowledge on the biology of sole in captivity and provide the core of this review.

In this review we synthesize the current knowledge of sole biology and ecology, and focus

on the current state of development of its culture in captivity. Emphasis will be put on addressing areas where knowledge is lacking, as this may assist scientists in pinpointing future challenges that need to be solved if this species is to become an important aquaculture species.

Aspects of natural biology of sole

Migration of sole

The studies of Greer Walker and Emerson (1990) and Rijnsdorp et al. (1992) indicate that *S. solea* does not undergo long migrations, but is a relatively stationary species. However, variation in spatial distribution between juveniles and adults is seen, as only large fish migrate to colder areas (Rijnsdorp et al., 1992). This may be partly explained by a decreasing temperature sensitivity and a downshift in temperature optimum with size, a common finding in flatfish (e.g., Imsland et al., 1996; Jonassen et al., 1999), whereas another explanation for this cold-water migration may be a reduced predation risk or search for new feeding grounds. Lack of long migration, together with the fact that this species is found over a wide geographical area makes it reasonable to assume that sole in European waters belong to more than one population. Cabral and Costa (1999) investigated the spatio-temporal pattern of estuarine use by *S. solea* and *S. senegalensis* in the Tagus estuary in Portugal (Figure 1). The highest densities of *S. solea* were recorded in deep, warm, low salinity areas with sediment of fine sand and high abundance of amphipods, whereas *S. senegalensis* had a wider distribution mainly related to food availability (Figure 2). Sympatry was only reported in one of four areas investigated.

Population genetics of sole

Intraspecies variation – S. solea (= vulgaris)

Kotoulas et al. (1995) investigated the genetic structure of *S. solea* on several spatial scales and at the temporal level through analysis of electrophoretic variation at 8–12 polymorphic enzymatic loci. No differentiation was apparent at the temporal scale. Some differentiation was detected at and above the regional scale. Isolation-by-distance

was evidenced by a significant correlation between genetic and geographic distances, and by the consistency of the results of multiple-locus correspondence analysis with geographic sampling patterns. The analysis suggested that the geographic unit of population structure (i.e., a geographical area corresponding to a panmictic or nearly panmictic population) lies within a radius of the order of 100 km. Kotoulas et al. (1995) pointed out that while there are life-history features in *S. solea* (i.e., high fecundity and long-lived planktonic larvae) that facilitate gene flow, other factors may favour geographic isolation (i.e., physical barriers in pelagic stage dispersion, homing behaviour of spawners, active vertical swimming of larvae). They concluded that water temperature during the reproductive period, which is critical for the survival of offspring during the pelagic stage, is a major factor affecting gene flow and consequently the population genetic structure of the species.

To investigate the genetic population structure of the Dover sole, *S. solea*, Exadactylos et al. (1998) collected 303 fish from seven locations ranging from Cumbria, Great Britain to Greece and analyzed a total of 22 enzyme systems, coded by 33 loci, with allozyme electrophoresis (Figure 3).

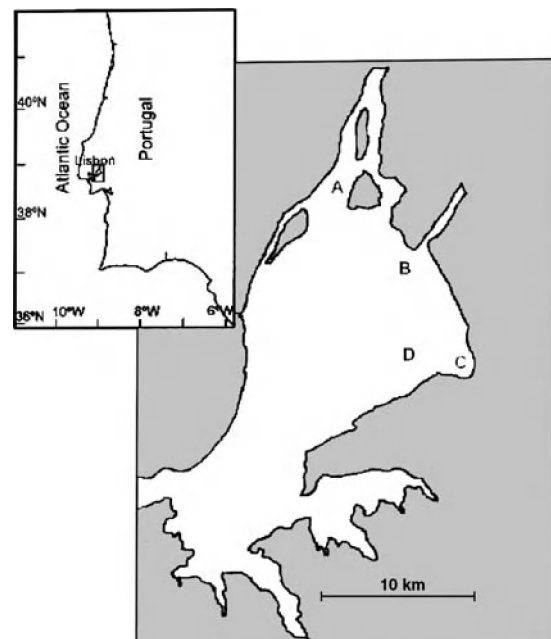

Figure 1. *Solea solea* vs. *Solea senegalensis*. Location of sampling in the Tagus estuary (from Cabral and Costa, 1999).

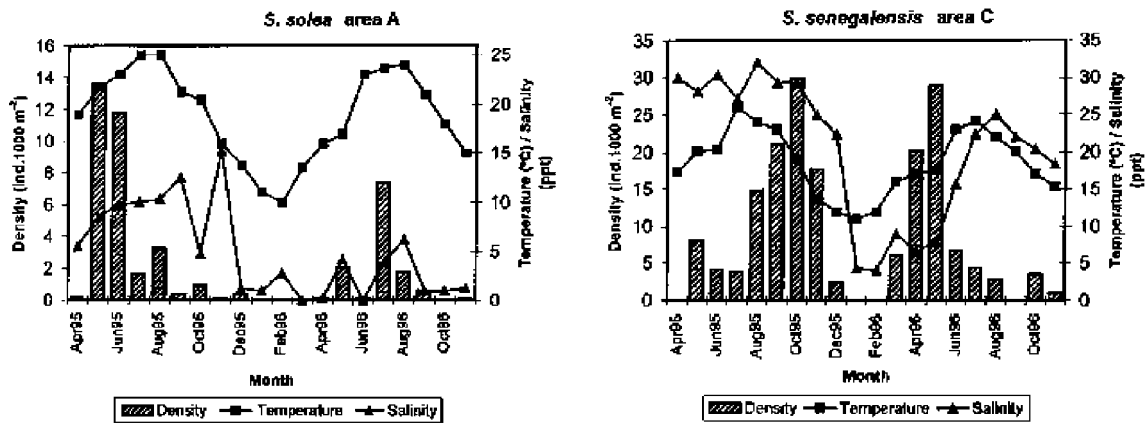

Figure 2. Monthly densities of *S. solea* in area A (left) and *S. senegalensis* in area C (right) and mean values of temperature and salinity (from Cabral and Costa, 1999).

Of these, 27 loci were polymorphic using the P-99 criterion. A phenogram using Prevosti's Distance generated by the Wagner method exhibited a geographic pattern in the clustering of populations. Estimates of N_m (effective number of migrants per generation between populations) were sufficiently high to imply near-panmixia between the North Sea, Bay of Biscay and the Irish Coast populations, indicating a probable movement of migrants through the English Channel. Despite this high level of gene flow, striking patterns of geographic differentiation were observed at a few loci (Figure 4). This pattern of genetic patchiness could be the result of localized selection, genetic drift or single-generation sampling effects. The absence of isolation-by-distance provides support for a model of geographic isolation. Such a pattern of genetic patchiness, revealing a slight reduction of genetic variability in the northern European basin, may suggest a population bottleneck, or local reduction in population size.

In general, the available literature on sole indicates that there are several distinct populations of sole in Europe. However, studies at the intra-specific level on *S. senegalensis* are lacking and DNA methods have not yet been applied to study the intra-population genetics of sole. Based on the allozymes studies it is suggested that sole in European waters consist of more than one metapopulation. Such genetic stock differentiation has previously been reported for several other flatfish species e.g., witch flounder, *Glyptocephalus cynoglossus* (Fairbairn, 1981), Pacific halibut, *Hippoglossus stenolepis* (Grant et al., 1984), Pacific black halibut, *Reinhardtius matsuurae* (Diakov,

1998), Atlantic halibut, *Hippoglossus hippoglossus* (Foss et al., 1998), turbot, *Scophthalmus maximus* (Imstrand et al., 2003b) and plaice, *Pleuronectes platessa* (Hoarau et al., 2002).

Interspecies variation – Solea spp.

Abd-El-Gawad et al., (1997) investigated specimens of *Solea aegyptiaca* and *Solea solea* from two different localities in Egypt. Esterase (*Est*) isozymes were compared electrophoretically using three organ tissues (heart, liver and kidney). *Est-3A* and *Est-2A* were the only loci invariably expressed in all organ tissues of both species analyzed. The phylogenetic relationships based on Nei's genetic distance revealed genetic divergence between *S. solea* and *S. aegyptiaca*.

In order to provide an independent insight into the systematics of the *Solea* genus, Tinti and Picinetti (2000) studied the molecular genetics

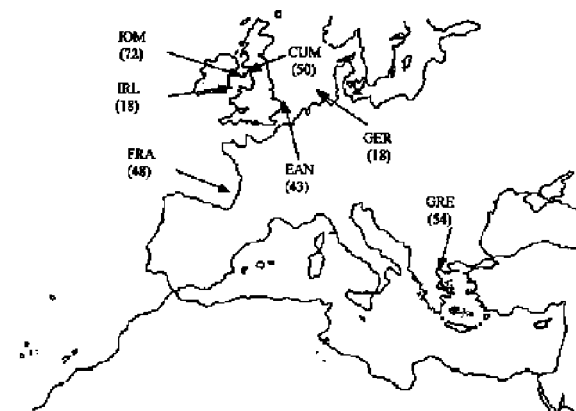

Figure 3. Sampling sites of *Solea solea* and number of samples at each site (from Exadactylos et al., 1998).

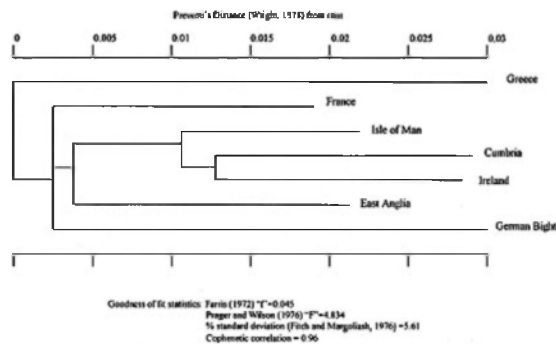

Figure 4. Dendrogram showing the genetic relationship between seven sampling sites of *Solea solea* (from Exadactylos et al., 1998).

of Atlanto-Mediterranean *Solea* species using sequence analysis of two mtDNA genes (Figure 5). Phylogenetic relationships were assessed applying different methods of analysis at the generic level of differentiation. Samples from seven taxa of *Solea* were taken in the Adriatic Sea, Gulf of Cádiz and Gulf of Taranto. Within the genus *Solea*, four sister lineages have evolved that actually correspond to the species *S. solea*, *S. senegalensis*, *S. kleini* and *S. lascaris*. The existence of *S. aegyptiaca* and *S. impar* were not supported by this study, and these species can be synonymized under *S. vulgaris* and *S. lascaris*, respectively (Figure 5). This pattern of taxonomy fully agrees with that proposed by Ben-Tuvia (1990) in a study investigating morphological features of these species. In addition, mtDNA data contradict the widely accepted relatedness between *S. kleini* and *S. lascaris* demonstrated by the shared enlarged fore-nostril on the blind side.

Both the study of Tinti and Picinetti (2000) and Ben-Tuvia (1990) supported the phylogenetic relatedness of *S. solea* and *S. senegalensis*, being found as closest sister lineages in most reconstructions. At the same time both approaches (i.e., molecular genetics and morphological traits) give diagnostic differences that lead consistently to their taxonomic separation at the specific rank.

Population separation and growth differences

If more than one panmictic population of sole exists in Europe it may be reasonable to believe that they may develop different life history strategies, as sole from the southern part of the species range experience a different temperature regime and photoperiod compared to fish from the

northern part of the species range based on temperature data obtained from ICES oceanographic database, Copenhagen, Denmark. Exadactylos et al. (1999) investigated the variation in multiple-loci and single-locus heterozygosity, and its correlation with growth rate, in laboratory-reared juvenile Dover sole from two populations, Irish sole and Norwegian sole. Genetic structure within each population was examined to test for genotype differences among individuals surviving past metamorphosis (70 days after hatching). Larval growth rate was significantly affected by rearing treatment (all groups reared at 12.4 ± 1.3 °C). Larvae from broodstock originating from the Irish Sea were larger at hatching, grew faster, and ini-

MOLECULAR SYSTEMATICS OF SOLEA

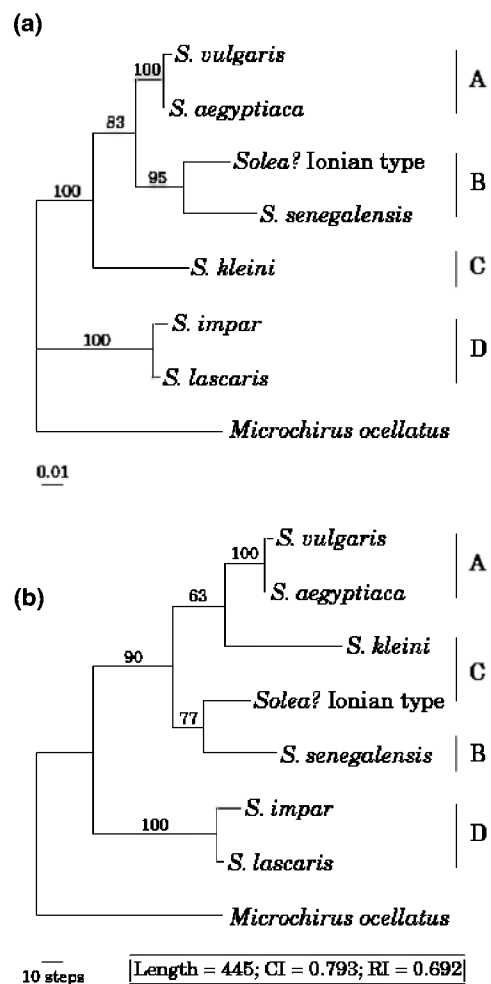

Figure 5. Maximum-likelihood (a) and maximum parsimony (b) phylogenetic tree for *Solea* taxa (from Tinti and Picinetti, 2000).

tiated metamorphosis earlier than larvae from broodstock originating from the Skagerrak–Kattegat (Figure 6). It is possible that these differences have a genetic basis and if so, they could be enhanced by genetic selection. Further, measures of genetic diversity (percentage of polymorphic loci, number of alleles per locus and heterozygosity) were considerably lower than those of wild populations indicating that only a few families were represented from each locality. Samples collected from sole hatcheries clearly demonstrated loss of genetic diversity, and marked changes in gene frequencies of cultured batches relative to the wild populations from which the parents were derived (Exadactylos et al., 1999). Such genetic bottlenecks have also been found in cultured turbot (Coughlan et al., 1998). This is possibly due to random genetic drift of allele frequencies in the hatcheries. However, some element of domestication or hatchery/ husbandry (deliberate or inadvertent) selection may have led to changes in the genetic composition of farmed strains compared to source populations. It has been suggested that reduced genetic variability can result in reduced performance in aquaculture strains (Coughlan et al., 1998) and it is important for the emerging sole aquaculture industry to bear this in mind and apply large broodstock collections to their founder material.

Environmental conditions – broodstock

Broodstock and treatment of S. solea

Sole readily spawn naturally in captivity and the buoyant, fertilized eggs are collected easily from the spawning ponds. This procedure is simple and effective and consequently, most published accounts of sole spawning in captivity are descriptive rather than analytical. The paper of Baynes et al. (1993) reviews the conditions and procedures used to obtain natural spawning from captive broodstock. This paper also describes the characteristics of egg production. It is clear that spawning of the species has been obtained under a wide range of conditions. The time of year may differ, even at the same location, but analysis of published data shows that the temperature at which it commenced was related directly to the minimum temperature of the previous winter.

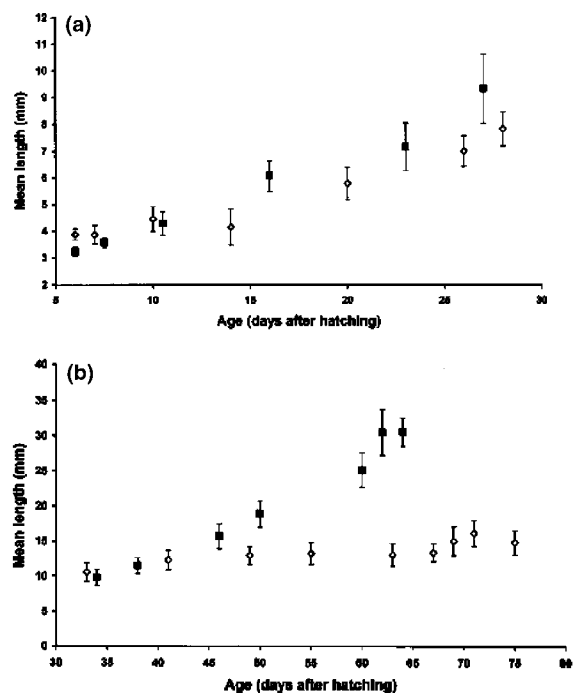

Figure 6. Length at age of Irish Sea (solid squares) and Norwegian (open diamonds) groups of sole larvae (a) during the larval stage and (b) after metamorphosis (from Exadactylos et al., 1999).

Annual relative fecundity has been demonstrated to vary from 10 to 140 eggs/g of female with a tendency for the higher values to have occurred following winter temperatures of less than approximately 12 °C. Variable fertilization rates are a common feature of eggs spawned by captive stocks with average fertilization rates for the complete spawning seasons ranging from 20 to 80% (Howell, 1997).

Spawning time

Spawning of sole has been displaced by several months by manipulation of photoperiod and temperature (Devauchelle et al., 1987) and by temperature alone (Lenzi and Salvatori, 1989). In the wild, spawning is related to temperature (Brittany, December/January, Déniel, 1990; North Sea, early spring, Fonds, 1976) and viable eggs are found in the temperature range of 8–12 °C. In captivity with ambient conditions Devauchelle et al., (1987) reported spawning conditions and production of eggs from 229 batches of sole in the period 1974–1986. These fish were wild caught and were divided into two groups. One group of

spawners was submitted to natural variations in temperature and photoperiod, whereas the other group was maintained under artificial cycles (temperature and light advanced by 4 months). Spawning in the ambient group took place between March and mid-May with temperatures between 8 and 12 °C and day lengths of 11–16 h of light. The corresponding dates for the advanced group were September to mid-November with temperatures between 8 and 15 °C with day lengths of 11–16 h of light. In the advanced group fewer eggs and more variable viability rates were observed. The authors concluded that sole has a rather narrow temperature range for spawning (8 and 12 °C) and that the species responds to photoperiodic and thermal stimulation in similar ways to those of most fish species in temperate areas. As studies on photoperiodic control of spawning in sole are very scarce, results will be given from studies on turbot (sole egg dry weight are almost the same as for turbot) to indicate a possible scenario (see below).

Reproductive strategies

Urban (1991) investigated the reproductive strategies of *S. solea* in the North Sea. The oocyte size frequency distributions of sole indicated that it is probably an indeterminate spawner where annual fecundity is determined during the spawning season (as opposed to plaice where annual fecundity is determined before the onset of the spawning season). In the case of sole, annual fecundity could not be based on oocyte size distribution before the onset of the spawning season as this would lead to overestimation of spawning stock biomass (wild caught fish). In sole, no gap between the unyolked reserve oocytes and the maturing oocytes was found. Very likely its oocyte development is continuous and it is impossible to say, until right before the onset of the spawning season, which oocytes will remain in the ovary for future years and which will be shed during the current spawning season.

Baynes et al. (1994) published a description of spawning behaviour of *S. solea* in captivity (tanks were 1 m deep × 3 m in diameter). Video recordings of the fish showed that the fish swim in pairs, with the male swimming into a position under the female where the genital pores are very close. This position is necessary, as the sperm duct opens at the end of a papilla on the dorsal surface and the

female's cloaca opens on the ventral margin. They would only be adjacent when the male is underneath the female. The male and female then swim together towards the water surface, with closely synchronized body movements, remaining together for up to 70 s, while maintaining a head-up position just beneath the surface.

To summarize the environmental conditions used for broodfish we find in published studies: sex ratio of 0.5–3 males to each female, moderate densities (0.6–3.0 kg/m³, Devauchelle et al., 1987), large tanks (>10 m³), with light intensity of 20–1500 lux, temperature should be kept between 8 and 12 °C with ambient fluctuations. Broodfish are fed *ad libitum* with fresh mollusc and polychetes at an average rate of about 10% body weight per week (Baynes et al., 1993). The fish are allowed to spawn naturally and fertilized eggs are collected in the water column. Temperatures are allowed to follow the annual cyclic regime were the difference between max and min temperature should be around or less than 12 °C. First signs of spawning are correlated to raising temperature in spring and this temperature rise may be an important environmental determinant for spawning. The use of photoperiod for manipulation of spawning has not been systematically studied for sole. Fecundity varies between 10 and 140 eggs/kg and fertilization rate between 20 and 80%. No indication of correlation between fertilization rates and sex ratios were found (Baynes et al., 1993).

Broodstock and treatment of S. senegalensis

The reproduction of *S. senegalensis* in captivity has been the subject of research since the early eighties (Rodriguez and Pascual, 1982; Rodriguez, 1984; Dinis, 1986, 1992; Bedoui, 1995).

Bedoui (1995) reared *Solea senegalensis* at an experimental scale. The rearing was conducted from broodstock to juveniles of 2 months. The broodstock was collected from the wild and acclimatized in a raceway with a sand bottom. Natural spawning was obtained at 18 °C during a 3-month period (April–June). The pelagic egg size ranged from 0.99 to 1.02 mm. The incubation was performed in stagnant water lasting 42 h at 19 °C. Dinis and Reis (1995, cited in Dinis et al., 1999) describe the broodstock management and larval rearing of *Solea senegalensis* obtained in a pilot-research project in Portugal since 1994. After

7 months in captivity, a wild broodstock spawned naturally and the spawning season lasted from March until June, at temperatures ranging from 16.5 ± 0.5 to 22 ± 1.0 °C and salinities from 30 to 35 ppt. Batches of eggs with 100% fertilization presented viability ranging from 90% to 100%. Newly hatched larvae had a total length of 2.6 ± 0.1 mm and were reared in 200 l fiberglass cylindroconical tanks.

Dinis et al. (1999) summarized culture experience with *S. senegalensis* in Portugal and Spain in the period 1993–1997. Natural spawning of broodstock in captivity was accomplished, and was the only way viable eggs were obtained. The broodstock feed regime was based on squid, *Loligo vulgaris*, and was supplemented with polychaetes, *Hediste diversicolor*, during final maturation. Temperature played a very important role in the onset and duration of the spawning period, with egg emission stopping below 16 °C. Observed duration of the spawning period ranged from 4 to 6 months. The total weight of the eggs collected daily during the spawning season ranged from 0 to 180 g for a broodstock of 15 fish (Figure 7). Egg fertilization rates varied between 20% and 100%, and the percentage of viable eggs (percentage of fertilized eggs hatching) was $72.1 \pm 26.5\%$ (Figure 8). Variations in egg size between batches were detected, with egg size tending to decline during the spawning season. Similar trend is found for *S. solea* (Baynes et al., 1993). In many fish species the proportion of viable eggs is related to age (see Marteinsdóttir and Begg, 2002), and there are indications of this for *S. senegalensis* (Dinis, M.D., unpublished data) as well as for turbot (Imsland, A.K., unpublished data) and halibut (Imsland, A.K., unpublished data). In *S. solea* larvae hatching

from larger eggs have more yolk, are longer and have deeper myotomes compared to those from smaller eggs (Baynes and Howell, 1996).

In conclusion available literature clearly indicates that the broodstock management and natural spawning in captivity can be achieved successfully (Dinis et al., 1999) and that spawning occurs normally in broodstock fed on squid supplemented with polychaetes. Stocking density in the maturation tanks should be 1–1.5 kg/m² and temperature should be kept above 16 °C as emission stops below that temperature. Recent data (Dinis et al., 2003) indicate that broodstock density might be up to 5 kg/m², and that the annual temperature cycle triggers sole maturation. In nature, the onset of spawning is related to the rise in temperature during spring (March–June). Portuguese studies indicate that *S. senegalensis* can be found in coastal and estuary areas where temperatures rise from approx. 16–25 °C during this period of year (Cabral and Costa, 1999; Dinis et al., 1999; Cabral, 2000). Salinity should be kept constant around 33–35‰ and the fish are reared under simulated natural photoperiod (LDN). In other cultured flatfish species a change in the photoperiod is the key environmental signal used to manipulate and control maturation (Imsland et al., 1997, 2003a; Norberg et al., 2001), but at the present time there are no published experimental studies to verify or contradict this for either *S. senegalensis* or *S. solea*.

Hormonally induced spawning and stripping of eggs

There are very few studies that describe hormonally induced spawning of sole. Ramos (1986a) describes how luteinizing hormone-releasing hormone analogue (LH-RHa) can be used to induce precocious ovulation in *S. solea*. Spawning was

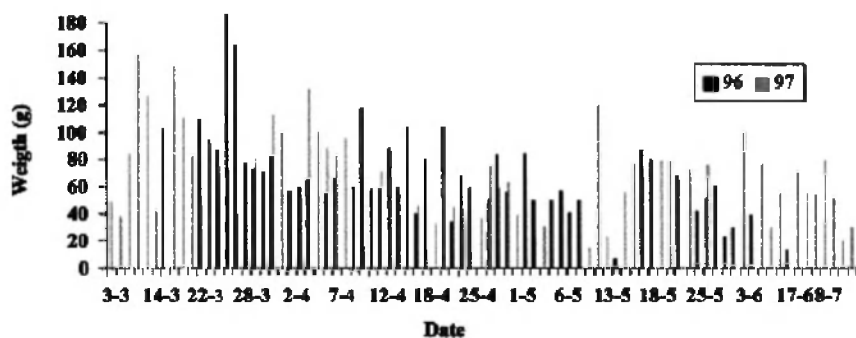

Figure 7. Total weight of eggs (daily collection) of *S. senegalensis* during spawning season in 1996–1997 (from Dinis et al., 1999).

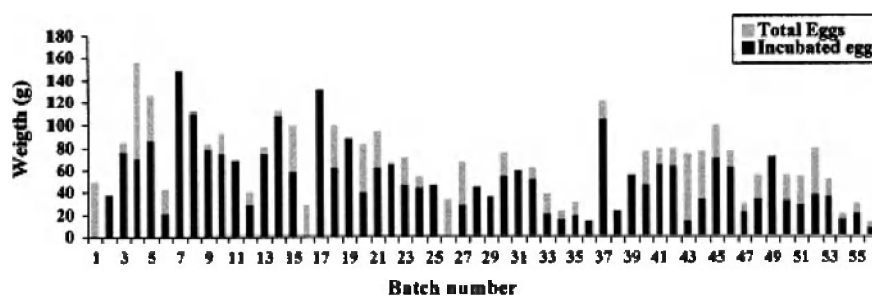

Figure 8. Viable and fertilized eggs per batch during the *S. senegalensis* spawning season of 1997 (from Dinis et al., 1999).

induced by a synthetic analogue of LH–RH administered at doses of 10 $\mu\text{g}/\text{kg}$ of body weight. The results suggest that LH–RH analogue accelerated maturation of the ovaries in females. Ramos (1986b) describes how human chorionic gonadotropin (HCG) can be used to induce spawning in common sole. Spawning was induced by injecting HCG (human chorionic gonadotropin) intramuscularly in single doses ranging from 250 to 1000 IU/kg fish. Low doses of HCG (250–500 IU/kg fish), injected into females with oocytes in the final stages of vitellogenesis induced spawning with the highest fertilization percentage, number of eggs and number of spawnings.

Experiments with human chorionic gonadotrophine (HCG) in *S. solea* (Girin, 1979), with pituitary extracts of carp and tuna (Rodriguez and Pascual, 1982) and luteinizing hormone-releasing hormone (LH–RH, Dinis, 1986, cited in Dinis et al., 1999) in *S. senegalensis*, did not result in viable spawns. In most cases the females did not ovulate, or the quality of the eggs was very poor. Although good results have been obtained with stripping in other flatfish species, e.g., turbot, the technique does not appear feasible in neither *Solea* spp. Natural conditioning and tank spawning is the only way viable eggs have been obtained to date in both sole species. In conclusion, the application of hormonal methods of spawning manipulation has not been used routinely and studies have given contradictory results.

Production of larvae and juveniles

S. solea

Incubation

Devauchelle et al. (1987) reported that the best incubation performances (defined as max %

hatching and min % deformed newly hatched larvae) for *S. solea* eggs was 13–15 °C, which is slightly higher than the optimal temperature for spawning found by the same authors (8–12 °C). Optimal salinity range for eggs and embryos is reported to be from 20‰ to 35‰ (Fonds, 1979a; Devauchelle et al., 1987). The size of the eggs ranged from 1.0 to 1.6 mm, and has been reported to decrease during the spawning season (Houghton et al., 1985; Baynes et al., 1993). Fonds (1979a) incubated sole eggs at five different temperatures between 10 and 22 °C and five different salinities between 20‰ and 50‰. High survival and normal development were observed at temperatures until hatching were observed at temperatures from 10 to 16 °C and salinities from 20‰ to 40‰. At 22 °C no viable larvae hatched and at 19 °C many embryos were abnormal. Survival was near 100% at 10 °C. Incubation time (i.e., from fertilization to start of feeding) was highly dependent on the incubation temperatures and was 27.5, 19.7 and 15 days at 10, 13 and 16 °C, respectively. The optimal temperature for successful development of the eggs was lower than the optimal temperature for growth of the larvae, as maximum growth rates were found at 19 and 22 °C.

Various types of experimental units have been used for incubation: rectangular 144 and 36 l tanks (Bromley, 1977), rectangular 120 l tanks (Fonds, 1979a), rectangular 35 l tanks (Devauchelle et al., 1987) and circular 20 l plastic tanks (Knutsen, 1992). All experimental units provided satisfactory results.

Larval nutrition and rearing

Howell (1997) reviewed the culture of *S. solea* and reported that rearing the larvae through metamorphosis presented few problems with survival rates being consistently in excess of 70% in small scale laboratory systems. The larvae can be reared

on a diet of freshly hatched *Artemia* nauplii without prior enrichment with algae or proprietary "booster" diets. The larvae have also been reared on a diet of rotifers, offered either as the exclusive food source (Howell, 1973) or in combination with *Artemia* nauplii (Fuchs, 1982), but survival was not enhanced by the availability of the smaller food organism in neither study. According to Howell (1997), the relative ease with which larvae can be reared may in part reflect the consistent quality of the fertilized eggs produced by captive stocks. Because these stocks are the product of natural spawning, they are not subject to varying quality caused by over-ripening, as is often evident in fish where the gametes are manually stripped.

Dietary requirement for ($n - 3$) HUFA in *S. solea* is found to be less stringent than in many other marine species (Howell and Tzoumas, 1991) so that enhancing the lipid content of *Artemia* is not a prerequisite for high larval survival as long as *Artemia* strains rich in eicosapentaenoic acid, 20:5($n - 3$), are used. Quantitative requirements for specific nutrients, particularly lipids, during the larval stages remain unknown. The effect of chemical stimuli on the feeding of larval *S. solea* has been investigated by Knutsen (1992). He found that in sole larvae, the most potent substances were L-phenylalanine, L-lysine, L-asparagine, inosine 5-monophosphate and betaine. The results show that feeding of sole larvae is influenced by chemosensory processes at an early larval stage and that chemoreception may be an integrated part of sole feeding strategy.

Weaning

During the last 20 years a number of studies have investigated several aspects of sole weaning. Bromley (1977) tried eight different diets and four different weaning methods for sole during day 25–40 post hatch (approximately 13 mm at start), and obtained best results from using a dry salmon feed as a weaning diet, attaining an average growth of 0.33 mm/day. Gatesoupe and Luquet (1982) fed sole larvae with live *Artemia* nauplii during the first few days of their life. The fish were then fed an artificial diet, semi-moist and crumbly in form. According to the authors, good results were obtained without supplying frozen nauplii in addition (15% and 28% survival from hatching up to day 70, respectively, for two lots abruptly weaned from day 10 or 11, with 50 and 90 mg as the final

mean weight, and a supply of 1980 or 2660 live nauplii per 70-day-old fish). The proportion of normally pigmented sole at the end of the experiments was between 13% and 70%. The differences between lots from the same spawning were found to be significant. This would indicate that unchecked rearing conditions may produce a very high level of pigmentation anomalies, a phenomenon frequently observed in the rearing of flatfish, e.g., in turbot (Heap and Thorpe, 1987) and halibut (Hemre et al., 2002). Fuchs (1982) obtained a mean weight of 400 mg in 60 days old sole, weaned by day 25, with 40% survival from this date. This survival rate might be expected with weaning prior to metamorphosis, but one would expect the growth rate to be 5–10 times lower, and the amount of live nauplii to be more than 12 times lower. According to Gatesoupe and Luquet (1982) there is a choice to be made between two ways of weaning (i.e., *Artemia* for 25 days, Fuchs, 1978 or *Artemia* for 5–15 days supplemented with an artificial diet, Gatesoupe and Luquet, 1982). The first gives higher growth but also high costs (due to *Artemia* expenses), and the second alternative is less costly but yields lower growth. In a later study Gatesoupe (1983) weaned sole from live *Artemia* onto a compound diet between 10 and 15 days after hatching (DAH), and by 70 DAH the weight was between 189 and 414 mg, which, according to the author, is comparable to growth achieved in weaning studies with *Artemia* up to day 25. By choosing this strategy, a 90% reduction in number of nauplii offered can be achieved, i.e., 3000 nauplii per surviving fish, compared to 25,000 nauplii per sole surviving in Fuchs (1978) study.

Cadena Roa et al. (1982) investigated the use of attractive substances in feed to increase the feed intake of sole during weaning. They used rehydratable extruded pellets because these are soft, palatable, resistant to leaking and can be sized. Furthermore, an attractant can easily be added to these pellets. During a 45-days experiment, extruded pellets containing only water, oils and vitamins, were compared with pellets mixed with the following additives: ground molluscs, ground *Artemia*, ground polychaetes, mixture of glycine, L-alanine, L-glutamic acid, L-arginine, betaine and inosine. As a result the crumble absorbed the substances they were mixed with. Supplementation with ground molluscs, *Artemia* or polychaetes did not result in better growth (specific growth rate,

1.5–3.0% per day) and survival (10–17%) than in the control (0.9% and 3.0%, respectively), whereas the mixture of chemical substances greatly enhanced those parameters (4% per day and 66%, respectively). Similar findings were reported in the study of Métailler et al. (1983) where betaine, glycine and inosine gave the best results as attractants. Further, Day et al. (1997) found that survival during the weaning period was positively correlated to the level of hydrolyzed fish protein concentrate, but they found no correlation with growth.

Appelbaum (1985) reared larval sole from first feeding to metamorphosis on *Artemia salina* nauplii, inert diets, or inert diets following pre-feeding with *Artemia*. The duration of the pre-feeding ranged from 0 to 10 days. Growth and development of the larvae receiving the different diets was monitored. The inert diets were prepared as microcapsules or as ground and sieved particles. The results demonstrated that sole larvae could be reared from first feeding to metamorphosis exclusively on inert diets. The longer the larvae were fed with *Artemia*, the greater were their rates of growth and development, but their mortality rate during weaning to a formulated diet was also higher. The best survival rate on an artificial diet was obtained when live *Artemia* nauplii were offered for the first 10 days. Appelbaum (1985) concluded that a certain proportion of a population of sole can be reared from eggs to juvenile fishes fed only a formulated diet. Recent weaning trials (Howell, 1998; Day et al., 1999) have been conducted using a commercial larvae feed produced by a process of agglomeration (Aglo-norse®). These trials have shown that this feed is capable of supporting weaning survival of *S. solea* close to 100% and achieve growth rates comparable to those found for groups fed on live foods (Howell, 1998; Day et al., 1999).

In conclusion, weaning has been started at different days post hatch, from 10 DAH (Gatesoupe and Luquet, 1982) to 25–40 DAH (Bromley, 1977). Studies indicate that a mixture of inert and live food may increase the weaning attractants in the dry feed (Cadena-Roa et al., 1982; Métailler et al., 1983). New studies (Howell, 1998; Day et al., 1999) have demonstrated that young sole can be weaned on to commercially prepared formulated feeds with high survival and growth approaching those attainable on live foods.

Substratum

Champalbert et al. (1992) investigated the influence of sediment on the settlement of juvenile sole (6–44 mm). Sediments of different grain size were used: mud (50–60 μm), fine sand (80–100 μm), coarse sand (200–250 μm) and gravel (1250–2500 μm). No differences in survival or growth were found. Sole sensitivity to sediment grain and/or colour varies with age. Metamorphosing larvae, or very recently metamorphosed juveniles, prefer settling on bright grounds, whatever the grain size. After metamorphosis, sole displays a tendency to settle on sandy substratum, preferentially on coarse sand or very fine mud. The tendency to choose bright sediment seems to decrease with increasing age. Moreover, soft ground is always preferred to hard bottom, even in animals never having experienced sand. Thus, sand appeared to be a suitable substratum.

Although, sand is at present time not used to facilitate settlement in hatcheries, growth of metamorphosed larvae seems to be better in rearing units with sandy substratum (M. Rigby, Llyn Aquaculture, Wales, personal communications).

S. senegalensis

Incubation

Incubation of *S. senegalensis* eggs has been performed using temperatures of 19 °C (Cañavate and Fernandez-Díaz, 1999) and 18–21 °C (Dinis et al., 1999). Various types of experimental units have been used for incubation: cylindro-conical 300 l tanks with gentle aeration and continuous up-welling at 0.5 l min⁻¹ (Cañavate and Fernandez-Díaz, 1999), 150 l fibreglass cylindroconical tanks (Dinis, 1992), 500 l fibreglass cylindroconical tanks (Vázquez et al., 1994).

Bedoui (1995) described how broodstock of *S. senegalensis* was collected from the wild and acclimated in a raceway with a sand bottom. Natural spawning was obtained at 18 °C during a 3 month period, April–June. The egg size ranged between 0.99 and 1.03 mm. The incubation was realized in stagnant water and lasted 42 h at 19 °C.

Larval nutrition and rearing

Bedoui (1995) fed *S. senegalensis* larvae exclusively on live *Artemia* followed by larger frozen *Artemia* until the fish were weaned. The size of the ingested prey and prey density increased with increase in

larval age. Starvation did not affect the ingested capacity. Magalhães (1997) and Aragão (1999) fed *S. senegalensis* larvae two diets. One group was fed on *Artemia* nauplii from first feeding and the other on rotifers (enriched in a mix of *Tetraselmis* sp. and *Isochrysis* sp.) during the first 5 days after hatching and *Artemia* nauplii thereafter. The results showed that feeding *S. senegalensis* larvae with *Artemia* nauplii from first feeding did not affect survival, growth or amino acid composition.

Dinis et al. (1996, 1999) described first feeding in *S. senegalensis* with larvae stocked at an initial density of 100 larvae/l. They reported that larvae hatch with an average size of 2.4 ± 0.1 mm total length, but varied widely by batch. The larvae were first fed *Brachionus plicatilis* from 3 to 5 DAH along with newly hatched *Artemia* nauplii from day 4 DAH onwards. During the larval period the environmental conditions were: normal photoperiod, 35 ppt salinity and a temperature of 18 °C. Larvae accepted newly hatched *Artemia* nauplii as first prey and reached a size of 8 mm by 15 DAH. Metamorphosis (i.e., start of eye migration) of started 11 days DAH and was completed 19 days DAH, with a total length of 7.3 ± 0.8 mm. From day 19 DAH the juveniles were fed *Artemia* metanauplii (reared for 48 h), and reached 16 ± 0.8 mm at day 40 DAH. Gavaia et al. (2002) tracked skeletal development during metamorphosis in *S. senegalensis*. Developing larvae were fed with newly hatched *Artemia* nauplii from 3 to 10 DAH, 24 h metanauplii from 11 DAH to metamorphosis, and 48 h metanauplii until the end of the experiment (approximately 180 DAH). These changes were defined as (a) eye migration from left to right side and concomitant bending of the urostyle, and (b) torsion of internal organs that starts during the process of eye migration, this process was initiated in larvae around 4.1 mm in standard length (SL) and ended when larvae were approximately 8 mm SL.

Vázquez et al. (1994) investigated changes in biochemical composition and fatty acid content during the early development of *S. senegalensis* (10–12 h after spawning, 36 h after hatching and 5 days after hatching) as an indicator of the nutritional requirements during the early life stages. Saturated and monounsaturated fatty acids such as 16:0, 16:1 n -7, 18:1 n -9, and 18:1 n -7 were utilized to a greater extent than polyunsaturated fatty acids as energy substrates. A requirement for

long-chain polyunsaturated fatty acids such as eicosapentaenoic acid, 20:5 n -3, and docosahexaenoic acid, 22:6 n -3, is likely since no evidence of bioconversion from their precursors was found. It seems that both *Solea* species are less dependent on polyunsaturated fatty acids during early development compared to many other marine species (Howell and Tzoumas, 1991; Vázquez et al. 1994), thus enhancing the lipid content of *Artemia* is not a prerequisite for high larval survival.

Yúfera et al. (1999) reared eggs and larvae of *S. senegalensis*, from fertilization until the end of metamorphosis, which occurred at 17 DAH at 19.5 °C. Changes in energy content and biomass quality were studied in terms of dry weight and of carbon, nitrogen and energy content. *S. senegalensis* spawned eggs of about 1 mm diameter which hatched 38 h after fertilization. Average dry weight of individual eggs was 46 µg, the chorion accounting for about 18% of the total dry weight. Gross energy of recently fertilized sole eggs was approximately 1 J/egg. From fertilization to hatching the eggs lost 8% of their total energy (chorion not included, Figure 9). After hatching, larvae lost 14% of their initial energy until the commencement of first feeding which occurred approximately 48 h after hatching. The principal components catabolized during embryogenesis were carbon-rich compounds that decreased by 26%, while nitrogen-rich compounds decreased by only 10% and were practically unaltered from hatching to the start of feeding. Feeding larvae displayed constant growth during the period studied (specific growth rate on a dry weight basis was 0.26/d). The relative proportion of carbon and nitrogen content revealed an accumulation of high energy compounds in the days before metamorphosis.

Weaning

As for *S. solea*, the onset of the weaning period for *S. senegalensis* differs among authors. Dinis (1992) started weaning *S. senegalensis* larvae at 31 DAH using rehydratable pellets, whereas Cañavate and Fernandez-Díaz (1999) used mixed diets of commercial formulated feed and live prey (rotifers and *Artemia*) from 3 to 43 DAH and only dry feed after that. Dinis (1992) initiated weaning to artificial diets when the juveniles were only 25 mg and based on comparison with data on *S. solea* the author indicated that better results could possibly

be obtained if weaning was initiated when the juveniles were larger. It may be reasonable to believe that larvae can be weaned 25–40 DAH as Ribeiro et al., (1999a, b) and Dinis et al. (2000) showed that *S. senegalensis* has a fully developed digestive tract, equipped with digestive enzymes and capable of ingesting, digesting and absorbing nutrients, 25–31 DAH (temperature between 18 and 25 °C). However there is some discrepancy in the timing of appearance of the first gastric glands, 18 DAH (Fehri-Bedouhi et al., 2000, temperature 19 °C) and 27 DAH (Ribeiro et al., 1999a, temperature between 16 and 19 °C) but completely developed gastric glands were only observed around 37 DAH (Sarasquete et al., 2001, temperature not given). The discrepancy may be partly due to differences in rearing temperature.

Cañavate and Fernandez-Díaz (1999) considered the feeding behaviour, growth and survival of larvae and metamorphosed fish of *S. senegalensis*. The presence of inert feed from first feeding was studied to determine when and how to effectively wean the species. Therefore, different treatments (see Table 1) that included inert and live feed were performed in order to determine the influence of co-feeding on weaning. Mixed diets of commercial formulated feed and live prey, i.e., L100I50 (100% live and 50% inert feed) and L50I50, allowed larvae to develop from first feeding to metamorphosis without significant differences in specific growth rate ($SGR = (e^{g-1}) * 100$, where $g = (\ln(w_2) - \ln(w_1)) / (t_2 - t_1)$) (20.7%/day and 19.8%/day, respectively) and survival (61.5% and 61.1%, respectively) compared to larvae fed live feed alone (i.e., L100, SGR of 20.2%/day and

survival of 71.6%, Figure 10). In metamorphosed fish, however, significant differences in survival after weaning onto commercial feeds occurred after 50 days of culture, compared to previous co-feeding with live and inert feeds during the larval stage. Metamorphosed fish previously fed a 1:1 ratio of live-inert feed during the larval stage (L50I50), had a similar SGR (5.2%) after weaning (day 70) to that obtained in fish fed only with *Artemia* (L100, SGR = 5.4%). When live feed was withdrawn on 43 DAH, there were significant differences in growth and survival among treatments. Sole larvae previously fed only live feed (L100 and L50) did not survive weaning to day 60. This study demonstrates the feasibility of early weaning of *S. senegalensis* and that larval co-feeding may enhance growth and survival after weaning. However, in another study (Engrola et al., unpublished), good survival rates (above 94%) were obtained in all treatments in *S. senegalensis* weaned at 40 DAH without any co-feeding, weaned with co-feeding with *Artemia*, and in a *Artemia*-fed control group. In this study, growth until 60 DAH was better in fish weaned without any co-feeding (SGR = 7.4%/day) compared to sole weaned with co-feeding or the *Artemia*-fed control group (SGR of 5.9 and 2.0%/day, respectively). Conflicting results between these two studies may be related to the different commercial weaning diets used and/or to differences in other rearing conditions. Strategies such as the use of protein hydrolyzates (Day et al., 1997), pulse fed treatment (Engrola et al., in press), high protein/lipid ratio in the diet (Dinis et al., 2000), and the development of new microencapsulated feeds

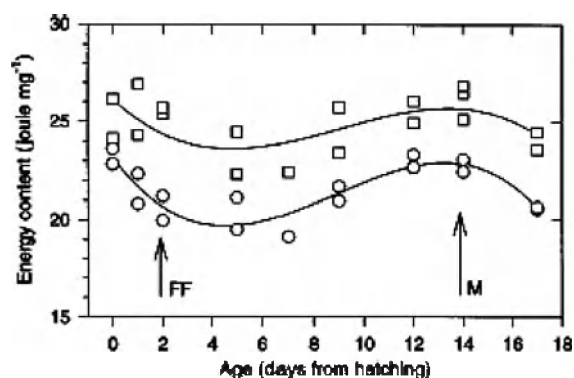

Figure 9. *Solea senegalensis*. Changes in energy content during larval development in J mg⁻¹ dry matter (○) and J mg⁻¹ ash-free dry matter (□) (FF first feeding; M start of metamorphosis) (from Yúfera et al., 1999).

Table 1. Description of the feeding regimes followed during the larval rearing of *S. senegalensis* (from Cañavate and Fernández-Díaz, 1999)

Feeding regime (days)	Algae ($\times 10^6$ cells ml^{-1})	Rotifers (ind ml^{-1})	<i>Artemia</i> (nauplii ml^{-1})	Dry feed (mg ml^{-1})
<i>L100</i>				
3–9	0.3	20	–	–
7–14	–	–	8	–
15–22	–	–	12	–
23–43	–	–	7	–
<i>L100I50</i>				
3–9	0.3	20	–	2.5
7–14	–	–	8	6.5
15–22	–	–	12	8.5
23–43	–	–	7	6
<i>L50</i>				
3–9	0.3	10	–	–
7–14	–	–	4	–
15–22	–	–	6	–
23–43	–	–	3.5	–
<i>L50I50</i>				
3–9	0.3	10	–	2.5
7–14	–	–	4	6.5
15–22	–	–	6	8.5
23–43	–	–	3.5	6
<i>I100</i>				
3–9	–	–	–	5
7–14	–	–	–	13
15–22	–	–	–	17
23–43	–	–	–	–

L = live prey; I = inert feed; 100 = full ration and 50 = half ration, e.g., L100I50 = full rotation live feed + half rotation inert feed.

(Yúfera et al., 1996; Fernández-Díaz and Yúfera, 1997), may contribute to improve reproducibility of weaning success of *S. senegalensis* on an industrial scale. Furthermore, the molecular form of the dietary amino acids, in particular the relative proportion in which different types of free amino acids (FAA), small peptides and proteins are present in the diet, may be important for growth. Recent studies (Rønnestad et al., 2001) have indicated that *S. senegalensis* use dispensable amino acids (DAA, e.g., glutamate and alanine) in preference to indispensable amino acids (IAA, e.g., lysine and arginine) as energy substrates, while

assimilation efficiency is better for IAA indicating that these amino acids are saved for body growth. Rønnestad et al. (2000) compared assimilation rates of FAA and proteins in postlarval *S. senegalensis* and found that the FAA diet was assimilated faster and with greater efficiency than the protein diet (80% vs. 58%). The authors pointed out that the challenge is to find proper feed production technologies and an appropriate inclusion level, so that the buffering capacity of the larvae and postlarvae for rapidly absorbing amino acids can be used to the maximum extent without reducing protein utilization, growth or survival rates. The importance of rearing practises and correct larval and postlarval feeding in *S. senegalensis* was recently highlighted in the study of Gavaia et al., (2002), where 44% of the larvae and juveniles studied had skeletal malformations of some kind. The causes were not identified, but such a high incidence of malformation may reflect culture problems related to rearing and/or nutrition.

Future experiments are needed to determine the time to commence weaning more precisely and determine the minimum duration of this period. Studies on alternative feeding strategies and on improvement of rearing conditions such as tank design, photoperiod, and light intensity, are also required.

Juvenile ongrowing

Ongrowing of S. solea

Effect of temperature

Of all environmental factors that influence the growth rate in fish, temperature is the single most dominant (Imsland and Jonassen, 2001). Temperature is a rate-controlling factor for all chemical processes in poikilotherms. However, comprehensive growth data for sole are lacking and there are very few studies that have tried to quantify the effects of temperature (Irvin, 1973; Fonds, 1976). Irvin (1973) monitored the growth rate of hatchery reared juvenile *S. solea* of an initial mean total length of about 5 cm at five temperatures ranging from 11 to 27 °C for 12 weeks. The fish were fed *ad libitum* on an oligochaete worm. The fish showed an approxi-

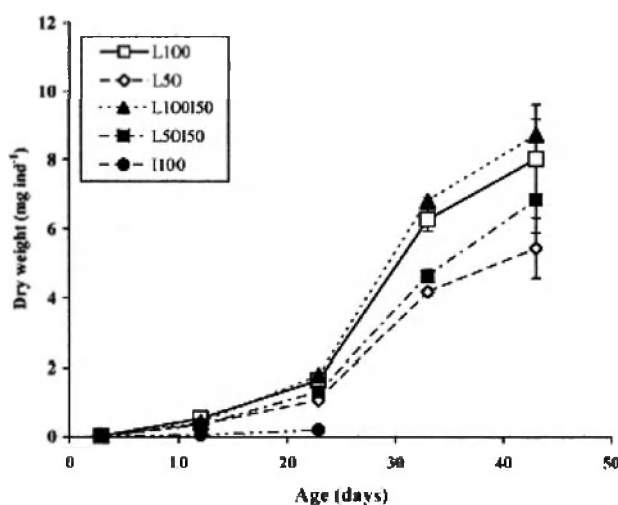

Figure 10. Changes in dry weight (mean \pm SD of two replicates) before weaning of *S. senegalensis* larvae with different feeding regimes. See Table 1 for details of the feeding regimes (from Cañavate and Fernández-Díaz, 1999).

mately linear increase in growth from 9 to 23 °C and a drop in growth after that (see Figure 11). Fonds (1976) worked with wild-caught *S. solea* of a larger initial size (12–13 cm) and followed their growth for over a year at temperatures ranging from 10 to 25 °C. The fish were fed daily with fresh chopped mussel (*Mytilus edulis*) or live lugworm (*Arenicola marina*). In his study he found that the fish grew slower as they were larger than the fish in Irvin's (1973) study, but both experiments showed little increase in growth rates above 20 °C and indicated that the optimum temperature for growth (i.e., T_{optG}) is between 20 and 25 °C. Howell (1997) extrapolated the data from these two studies and found that fish of about 5 cm may reach minimum market size of 24 cm (125 g) at temperatures close to optimum in less than 300 days (Figure 12).

Day et al. (1997) reared weaned juveniles for an 18-month period at an average temperature of 16.5 °C achieving a final average weight of 133 g \pm 40 SD (217.5 mm \pm 19.1 SD). The study showed that intensive on-growing of sole may be performed in sand-free tanks, as a near market size of 22 cm may be obtained in 18 months with no mortalities. The growth rates reported in this study are similar to those reported by Danielssen and Gulbrandsen (1989), who reared sole on chopped blue mussel for the first 150 days followed by pellets containing blue mussel and squid.

Effect of photoperiod

Photostimulation affects fish growth through better food conversion efficiency, and not just through stimulated food intake (see review by Boeuf and Le Bail, 1999), but by increasing the production of somatotropin. Under altered photoperiods in commercial fish farming, fish are expected to gradually adjust from low metabolism under short day length, to higher feeding activity, growth, and food utilization under a summer photoperiod (Boehlert, 1981; Woiwode and Adelman, 1991). Both the direction and the rate of change in day length may influence these processes (Imsland and Jonassen, 2001). Seasonal variations in growth rate in wild populations of sole are known (Rogers, 1994), although the changes caused by photoperiod *per se* are difficult to isolate from other concurrent changes such as temperature. Moreover, studies on the effect of photoperiod on growth of flatfish reared at constant temperatures are contradictory. Fuchs (1978) found no significant effect of photoperiod on growth of *S. solea*, whereas other studies have demonstrated growth-enhancing effects of extended photoperiod on plaice and sole (Fonds, 1979b), greenback flounder (*Rhombosolea tapirina*) (Hart et al., 1996), turbot (Imsland et al., 1995, 1997) and halibut (Simensen et al., 2000). However, the growth-enhancing effect of extended photoperiod in these studies is subtle compared to

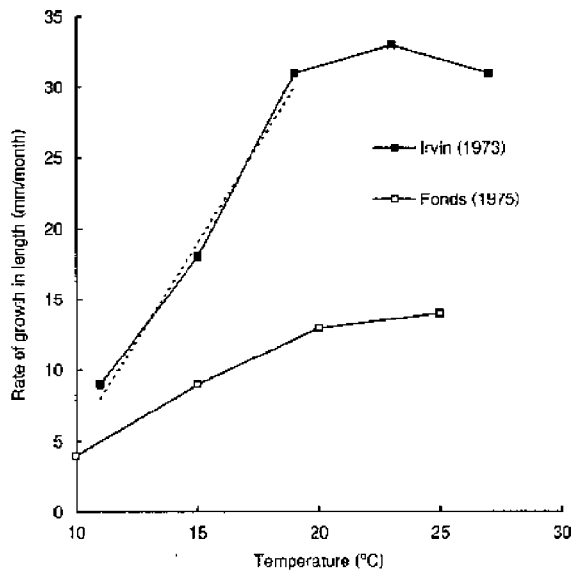

Figure 11. The relationship between rate of increase in length and temperatures for juvenile *S. solea* calculated from Irvin (1973) and Fonds (1976). For Irvin's data the regression of growth rate on temperatures from 11 to 19 °C is shown (dotted line) (from Howell, 1997).

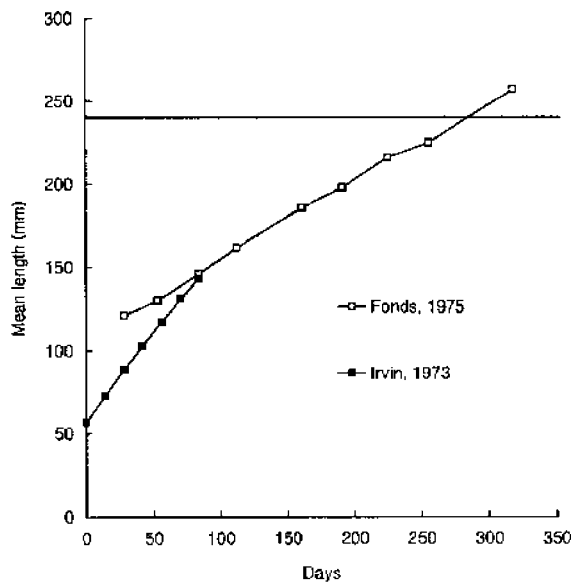

Figure 12. The increase in length of *S. solea* fed an ad libitum diet of an oligochaete worm at 19 °C and mussel and lugworm at 20 °C. The horizontal line shows the minimum market size of 24 cm (from Howell, 1997).

that observed in salmonids (Stefansson et al., 1989, 1991; Solbakken et al., 1994).

Fuchs (1978) investigated the effect of photoperiod on survival and growth of cultured young

sole from hatching to the age of 3 months, at 18 °C. Two experiments were performed, comparing days with 12, 18 and 24 h light. The fish were reared in 60 l conical tanks, until metamorphosis, and in square tanks with a sandy bottom from metamorphosis to the age of 3 months. They were fed on live food organisms for 1 month and frozen flesh of the bivalve *Laevicardium crassum* for the two other months. During the rest of the experiment, no significant difference between treatments was recorded in the survival rate, but a better growth was obtained at 18 and 24 h light, suggesting a predominant diurnal feeding. From metamorphosis to the age of 3 months (mean weight 1 g) no significant effect of photoperiod on survival and growth of the juveniles could be demonstrated. In another study, Fonds (1979b) reared juvenile plaice and sole at different constant temperatures and a natural light-dark cycle for 1 year. Food digestion and growth of the fish were measured at monthly intervals. The amount of food digested in 24 h was correlated with the metabolic weight of the fish, while growth rate was correlated with the size of the fish and the water temperature. Feeding and growth showed a seasonal variation, possibly correlated with the change in the day-night cycle.

Photoperiod has not been studied systematically in either sole species and the relative importance of a direct photoperiod effect on growth in sole therefore remains to be defined. Further, a possible interaction of photoperiod and temperature has not been studied in sole, although such an interaction was found to enhance growth by up to 10% at lower temperatures in other marine species (Imstrand et al., 1995; Jonassen et al., 2000).

Salinity

Marine teleosts have a blood concentration of ions lower than that of seawater (Zadunaisky, 1984), and regulate their internal osmotic pressure to a level equivalent to a salinity of 12–15‰ (Brett, 1979). Accordingly, marine fish species expend a certain amount of energy to meet the metabolic cost of ionic and osmotic regulation, and it has been hypothesized that if the external environment was manipulated so that the costs of ionic regulation was lowered, then the growth and food conversion efficiency of the fish would be improved. Furthermore, members of the Pleuronectidae family are sometimes found in freshwater

(Evans, 1984), and some, like flounder, sole and turbot, may be considered euryhaline.

Cabral and Costa (1999) investigated the spatio-temporal pattern of estuarine use in the Tagus estuary of both *S. solea* and *S. senegalensis*. The authors found the highest densities of *S. solea* in deep, warmer, low salinity areas, whereas *S. senegalensis* had a wider distribution and its abundance was more related to food availability. Champalbert et al. (1994) showed that juvenile *S. solea* can withstand low salinities and show an increased rheotaxis during periods of low salinity. As such this may indicate that salinity can effect the feeding behaviour or/and growth dynamics of sole. For turbot (Imstrand et al., 2001, 2002) rearing juveniles at intermediate salinities improved growth by 10–15% compared to full salinity. Whether similar results can be obtained in sole is unclear, but this is clearly an area for future research.

Stocking density

Although density is a key element in rearing of sole, few systematic investigations exist for this species. Howell (1998) described the effects of stocking density on the growth of turbot and *S. solea*. In his study, conditions were created that minimized the effects of water quality to enable social effects to be quantified. Growth of turbot was unaffected until the combined area of the fish exceeded 200% tank bottom coverage. In sole, growth was inversely related to stocking densities although percentage cover ranged from only 5% to 130%. It was postulated that the differing response to crowding in these two species could be related to their feeding behaviour. In contrast to turbot feeding behaviour, sole are adapted to eating small but frequent meals. This type of behaviour provides greater opportunities for interaction between individuals within communal groups than what is typically displayed in turbot, which is readily satiated by a relatively small number of feeding opportunities. This may indicate that sole is less well suited to intensive culture conditions than some other species. An experiment in which sole was grown from a mean length of 5 cm (1.5 g) to 10 cm (10–13 g), under conditions designed to quantify social rather than water quality effects on growth, demonstrated a significant negative effect of stocking density on growth (Howell, 1997, Figure 13).

Hierarchical effects and other social interactions were more apparent in sole as the oligochaete worm (*Lumbricillus rivalis*) they were fed with was concentrated in a small number of clumps in each tank leading to dominance hierarchies. It is possible that if fed formulated pellets, which are more evenly distributed in the tanks, this dominant behaviour would have become less prominent. Further studies on the effects of feeding strategy and stocking density are needed.

Ongrowing of S. senegalensis

Dinis et al. (1999) investigated growth of juvenile *S. senegalensis* during an experimental ongrowing trial. Two types of earthen ponds were stocked with unweaned juveniles. Annual temperature in the ponds fluctuated between 15 °C (January) and 24 °C (July). One pond (1000 m²) was equipped with nets at the water entrance to exclude predators and competitors. No food was supplied and the fish were only fed on naturally occurring prey. A total of 2000 fish were stocked in this pond in late July. One year later the pond was harvested and 20% of stocked fish were captured. After 1 year, the fish had obtained an average total length of 16.6 ± 2.1 cm and weighed 40.3 ± 2.5 g. Fish were also stocked in a pond with *Sparus aurata*, at a density of 2 sole juveniles/m². In this pond, the fish were fed with pellets. After 1 year, the fish had obtained a total length of 35.3 ± 1.8 cm and weighed 456.1 ± 3.6 g, with a survival of 8%. Studies of benthic fauna in commercial seabream ponds, carried out by Pousão-Ferreira et al. (1995), reported a high occurrence of polychaetes, which may explain the good growth obtained in the former study.

The effect of different feeding frequencies and night versus day feeding, has been studied in juvenile (15–30 g) *S. senegalensis* (Engrola et al., 2002). Higher feeding frequencies seem to reduce growth heterogeneity, but have little effect on mean growth rates. The light regime does not seem to have a major effect on feed intake or mean growth, but in general tend to show a slight improvement under illuminated conditions. Juvenile *S. senegalensis* (10–25 g) seem to be little affected by stocking densities up to 4.5 kg/m² (Engrola et al., 2001). Still, the smaller fish in a batch seem to grow better if graded and reared at lower densities.

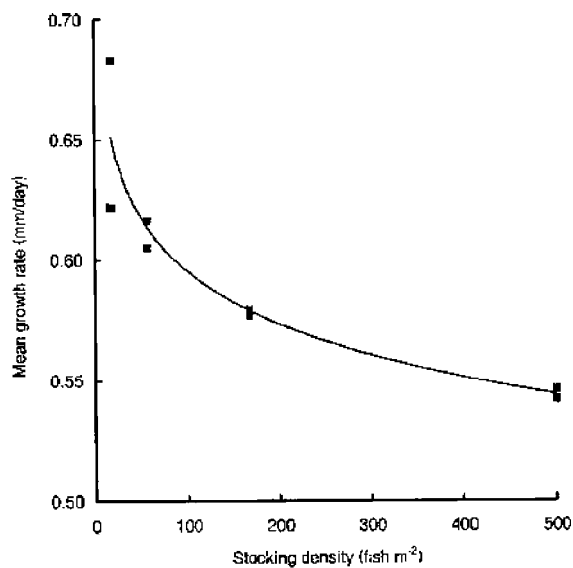

Figure 13. The relationship between stocking density and growth of sole of an initial mean length of about 5 cm grown for 12 weeks. The line was calculated by linear regression of growth rate (L) on logarithmic values of stocking density (D) and is represented by the equation $L = 0.74 - 0.073 \log D$ (from Howell, 1997).

Coutteau et al. (2001) evaluated the potential of formulated feed developed specifically for sole, and compared it with a commercial turbot feed for on-growing of *S. senegalensis*. The sole feed was a sinking extruded particle (INVE sole) with a crude protein to crude fat ratio of 55/16, and with a mixture of selected attractants to enhance attractability. A standard commercial turbot feed with a protein/crude fat ratio of 52/20 served as a reference. A pellet size of 2 mm was used in both treatments. Overall performance was better in the group receiving formulated feed developed for sole, than in the group receiving turbot feed, in terms of growth (12% higher daily growth rate) and food conversion (20% lower FCR). Average daily feed consumption (C), expressed as % of average body weight per day, was 12% lower for the sole feed (Table 2). Therefore, the authors concluded that the nutritional requirements of *S. senegalensis* may not be optimally met by a standard commercial turbot feed and improved growth and food conversion can be obtained by using specific sole formulations.

There is no information available concerning both optimal dietary protein level and optimal dietary protein/energy ratios for *S. senegalensis*

juveniles. It seems clear that dietary protein requirements are higher for flatfish than for other finfish. The protein requirements for maximum growth of turbot, sole, plaice and Atlantic halibut ranges between 50% and 65% of the diet (Berge and Storebakken, 1991; Guillaume et al., 1991; Aksnes et al., 1996; Helland and Grisdale-Helland, 1998). Available studies dealing with the optimization of the dietary protein/energy interaction in flatfish species (i.e., turbot, halibut and plaice) do not clarify whether the use of high energy diets with low digestible protein/digestible energy ratios enhance growth, feed efficiency, protein sparing and reduce nitrogenous losses, as happens with both salmonids and other marine species such as the European seabass (Médale et al., 1995; Dias et al., 1998).

Increasingly attempts are being made to incorporate non-protein energy sources (fats or carbohydrates) into fish diets, with the expectation that these sources will spare the dietary protein. A decline in growth rate with increasing dietary fat levels has been reported in juvenile turbot (Caceres-Martinez et al., 1984; Regost et al., 2001). Recent work (Dias et al., in press) suggests a tendency to an overall improvement of growth performance of juvenile *S. senegalensis* fed low dietary lipid levels with absence of a clear protein sparing effect of dietary fats, contrary to what is reported in many other species. This absence of a protein sparing effect by inclusion of dietary fats has also been reported in turbot (Regost et al., 2001). In the study of Dias et al. (in press) the activities of key hepatic lipogenic enzymes in juvenile *S. senegalensis* were depressed by elevated levels of dietary lipid, confirming the inhibitory effect of dietary fats on lipid biosynthesis. Furthermore, high fat diets increased whole-body, liver, viscera and muscle lipid contents. Whole-body fat content and daily fat gain increased in fish fed diets with higher lipid content. Such observations have been reported in flatfish species, such as turbot and Atlantic halibut (Andersen and Alsted, 1993; Aksnes et al., 1996; Regost et al., 2001). In addition, different dietary carbohydrate to lipid ratios do not seem to affect growth performance in Senegalese sole juveniles (Rueda-Jasso et al., in press), but seems to condition tissue lipid deposition and tissue oxidative status.

Aragão et al. (2003) has shown that replacement of fish meal by a soy protein concentrate

Table 2. Growth and feed utilization in *S. senegalensis* fed a specific sole formulation (INVE sole) in comparison with a standard commercial turbot feed (COMM turbot)

	INVE sole feed	COMM turbot feed	% difference INVE/COMM
Survival (%)	100 ± 0	100 ± 0	0
Initial weight (g)	14.7 ± 0.6	14.1 ± 1.1	+4
Final weight (g)	39.8 ± 0.7 a	34.4 ± 2.8 b	+16
Weight gain (g)	25.1 ± 1.2 a	20.3 ± 1.9 b	+24
C (%/d)	1.75 ± 0.09 a	1.56 ± 0.07 b	+12
Total feed/ind (g)	21.6 ± 0.3	21.7 ± 0.8	0
Feed intake (% ABW/d)	1.39 ± 0.01 a	1.58 ± 0.08 b	-12
FCR	0.86 ± 0.05 a	1.07 ± 0.06 b	-20

Data represent averages of three tanks and different letters denote significant differences (*t*-test, $p < 0.05$) (from Coutteau et al., 2001).

(SPC) as the main protein source does not affect growth, feed conversion efficiency, amino acid metabolism or survival in Senegalese sole post-larvae (0.4 mg), at least at high dietary protein levels (>55% protein). Still, the higher variability in some of these parameters in fish fed the SPC based diet suggests that there is a strong variation in utilization of SPC protein by individual fish.

It can be concluded that *S. senegalensis* has an apparent good adaptation capacity to different diet compositions and feeding regimes. However, sub-optimal feed formulations or inadequate feeding practices may impose a toll in terms of growth heterogeneity, nitrogen waste output or flesh quality. Further studies are required regarding optimal rearing technology and conditions, feeding behaviour and nutritional requirements.

Diseases

S. solea

Black patch necrosis (BPN)

Early work on the culture of sole, *S. solea* revealed that the species appeared to be extremely vulnerable to diseases (see discussion in Baynes and Howell, 1993). The most common and devastating of these is black patch necrosis (BPN), a condition first described by McVicar and White (1979) and later confirmed to be caused by the bacterium *Flexibacter maritimus* (Bernadet et al., 1990). BPN is reported to be highly infectious, but was found to be both prevented and controlled by providing a sand substrate in the rearing tanks (McVicar and White, 1982). Although it has been widely held

that a sand substrate is essential for successful culture of juvenile sole, later research has shown that this is not necessarily so and that sole may not be as vulnerable to disease as these early trials suggested.

Baynes and Howell (1993) investigated the growth and survival of groups of juvenile *S. solea* (size range 2.5–6.6 g) fed exclusively fresh or heat-treated and frozen (stored) mussel, *Mytilus edulis*, and assessed the effect of supplementing the stored mussel with one and two meals of fresh mussel per week. Over the experimental 9 weeks, the survival of the fish fed fresh mussel exceeded 90%. In contrast, less than 3% of those fed stored mussel alone survived. The inclusion of two meals of fresh mussel per week increased survival to the same level as that of the groups fed only fresh mussel, though growth rates were significantly lower. The high mortalities observed in the group fed stored mussel were associated with an outbreak of the disease “black patch necrosis” (BPN). The fish fed fresh mussel did not develop the same symptoms despite their proximity to infected fish and a lack of precautions to prevent the disease from spreading. The fish were not provided with a sand substrate, which has often been considered necessary for sole on-growing. It was suggested that a combination of adequate nutrition and attention to tank cleanliness was sufficient to avoid the occurrence of BPN and that the provision of a sand substrate is not a prerequisite for successful culture of juvenile sole.

Vibriosis

Baudin-Laurencin (1986) investigated the susceptibility of *S. solea* to vibriosis. In France, vibriosis

affects the majority of cultured fish and in all cases this is a septicaemia caused by a specific *Vibrio anguillarum* strain: *V. ang.* 408. The resistance to this strain was tested in juvenile *S. solea* (6–11 g) by exposing the fish to infecting baths for 15 min. Eight days after bath contamination (15 min with 3×10^9 and 3×10^{10} bacteria) cultures from anterior kidney and intestine did not reveal occurrence of the bacteria. Therefore, juvenile sole seems fairly resistant to *V. anguillarum* 408, at least if the level of virulent bacteria is not very high. The presence of low agglutination titers led the author to hypothesize of a specific immunity.

Other diseases

Flüchter (1979) described three bacterial diseases in *S. solea* (tailrot, furunculosis and red-spot disease). A *Pseudomonas* was associated with the first two and a *Vibrio* with the third. Tailrot and furunculosis could be cured by treating the fish with antibiotics (Table 3), but the red-spot disease was untreatable, because of a very rapid progression and late on-set of clinical signs. Ectoparasites probably facilitate the entry of disease organisms. The author highlighted the importance of prophylactic action in the rearing of sole. Recently was the first occurrence of viral nervous necrosis (VNN) in *S. solea* documented (Starkey et al., 2001). This disease is characterized by the development of a vacuolating encephalopathy and retinopathy associated with arrays of virus-like particles in infected neurons. This disease has been associated with high mortalities in farmed Atlantic halibut in Norway (Grotmol et al., 1997) and has the potential to cause severe economic loss in farming of marine species (Starkey et al., 2001). This finding highlights the need of effective control measures and for continued epidemiological surveillance.

S. senegalensis

Pasteurellosis

Zorrilla et al. (1999) reported the first description of pasteurellosis affecting *S. senegalensis* cultured in the southwest of Spain. Infected fish exhibited no apparent lesions except for a dark skin pigmentation and swelling in the abdominal cavity. Affected specimens showed paleness of liver and

kidney and typical white tubercles of 1–2 mm in diameter in the spleen. Microbiological analysis of these fish revealed the presence of a bacterial colony in all organs examined, which was biochemically and serologically characterized as *Photobacterium damsela* ssp. *piscicida*. This bacteria is the causative agent of pasteurellosis, a disease which provokes massive mortalities in cultures of several marine fish species. All strains of *P. damsela* ssp. *piscicida* displayed the same drug resistance pattern, being sensitive to novobiocin, ampicillin, chloramphenicol, tetracycline, oxytetracycline, oxolinic acid, nitrofurantoin, and trimethoprim-sulfathoxazole and to the vibriostatic compound 0/129, and resistant to streptomycin, erythromycin and kanamycin.

Vibriosis

In February 2001, an outbreak associated with moderate mortalities (20%) in populations of *S. senegalensis* cultured in a farm in south Spain was observed (Zorrilla et al., 2003). Bacteria isolated from the outbreak were identified as *Vibrio harveyi* and *V. parahaemolyticus*. Only bacterial strains showing swarming were virulent and caused mortalities in experimentally inoculated fish. The intramuscular inoculation of the extracellular products (ECPs) of both *Vibrio* species produced mortalities and appearance of surface ulcers in the case of *V. harveyi*. For both species vaccination with sublethal doses of ECP reduced mortality by 32–37% (*V. parahaemolyticus*) and 76–83% (*V. harveyi*) compared to unvaccinated fish. It

Table 3. Sensitivity of the pathogenic bacteria to some antibiotics (from Flüchter, 1979)

Antibiotic	Tailrot	Furunculosis	Red-spot disease
Penicillin	(-)	++	(-)
Dihydrostreptomycin	+	+	
Ampicillin	(+)	++	(-)
Tetracyclin	(-)	(+)	(-)
Chloramphenical	++	++	
Spiromycin	(-)	+	(-)
Kanamycin	(+)	+	(-)
Colistin	++	++	(-)

(-), Resistant; +, sensitive; (+), sensitive but not all strains; ++, highly sensitive.

was concluded that ECP could be considered as protective antigens to design potential vaccines against vibriosis in *S. senegalensis*.

Other diseases

In Spain there have been outbreaks of a disease with high mortality affecting *S. senegalensis*. This disease is characterized by dark coloration, hyperactivity, erratic swimming and abnormal behaviour. Rodriguez et al. (1997) isolated and characterized a birnavirus, named solevirus, from the skin and internal organs of moribound and dead soles. A serological comparison of solevirus with reference strains of IPNV (infections pancreatic necrosis virus) showed that the virus is clearly related to the Sp serotype, which is the most common serotype in Spain (Perez-Prieto et al., 2001).

Culture systems

Farming in recirculation systems – cost analysis

Kamstra et al. (2001) gave an analysis of the prospects for farming of *S. solea* using a recirculation system based on a bio-economic model. The authors collected data from the literature and own experimental research and projected these data into the infrastructure of a Dutch recirculation system. A case study was performed for a farm producing 50 tons/year. Data on growth rate (SGR, % d⁻¹) in relation to body weight (*W*, g) of *S. solea* from different authors were plotted and this resulted in the growth equation: $SGR = 18.16 * W^{-0.77}$. An average fish needs 17 months to grow from 5 to 300 g under this scenario. Data on growth in fish larger than 100 g is scarce so this equation might not correctly estimate the growth of fish >100 g. The strict bottom-feeding behaviour of the species results in a reduction in growth with increasing densities. The overall productivity (*P*, kg/m²/year) derived from their data was rather low with 35 kg/m²/year. The variable costs per kg end product of the most important items were estimated to be: fingerlings (5 g) – 1.42 €/kg; feed – 1.36 €/kg; electricity – 0.70 €/kg; oxygen, gas, water – 0.45 €/kg. Interest and depreciation were estimated to be 0.84 €/kg and 0.69 €/kg, respectively. Labour costs were estimated around 2 €/kg. The total cost price

in the base-case was estimated to be 7.59 €/kg. Using the market price of a small to middle sized fish of 10 €/kg the base-case results gave an internal rate of return of 13.2 (over 15 years) and a net-present value of 362.000 €. The authors concluded that farming of sole in recirculation systems could be an interesting business proposal, but that more data on growth and productivity of large fish were needed. Moreover, the financial results were very sensitive with respect to productivity and market price.

Earthen ponds

Earthen ponds are commonly used in the Mediterranean for seabass and seabream culture. So far all attempts by several commercial farms to grow sole in earthen ponds failed. This was due to the bottom feeding behaviour of the sole, making pond management extremely difficult. For the introduction of sole culture it would of course be very convenient if existing facilities can be utilized. It makes the switch less risky as it requires lower investments. Therefore, earthen ponds could be very attractive for ongrowing sole in this region and this deserves serious attention. In addition, sole culture in ponds offers the opportunity for polyculture. Previous attempts of ongrowing sole in ponds are believed to have failed due to stocking small unweaned fish (<0.2 g), and to failure in eliminating natural predators from the ponds prior to sole introduction. This could be avoided by stocking sole at a larger size and by sun drying the ponds prior to use. The aquaculture company Viveiro Vilanova (south Portugal) is currently testing ongrowing of *S. senegalensis* in three earthen ponds of one hectare each. Weaned (1–2 g) *S. senegalensis* were stocked in the ponds at the size of 5 g and will be reared in ponds for 18–24 months. Annual temperatures in these ponds are between 14 and 22 °C. Trials are ongoing, but initial results are promising (L. Conceição, CCMAR, University of Algarve, personal communications).

Shallow raceways

The idea of using shallow raceways (SRW, Figure 14) of up to 40 m in length appeared in the late eighties and has been developed in an experimental

scale by Øiestad (1999) and others. The principle has been demonstrated to work in single raceways without the reuse of water (flow through once). However, to be able to fully exploit the benefits of the SRW on an industrial scale with multi-level raceway racks, with reuse of water, several development tasks still needs to be performed. The technology is especially well suited for land-based production of flatfish like turbot, as they open possibilities for reduced land requirement and building investments as well as reduced water consumption, by stacking the raceways in several levels. It is obvious that flatfish production needs area more than volume. Typically, a 100-tonne annual production of turbot will demand a space of 1000–2000 m². The same production in shallow raceways in an eight-level rack will reduce the space needed to less than 200 m². If the sea water can be re-used from level to level in the rack, the need for water can be 1/10 or less that of a flow-through system. As the raceways are self-cleaning, labour costs can also be minimized (Øiestad, 1999).

The system has been tested on five flatfish species, three bottom-dwelling species and two open-water species (Table 4). The main effort has been on turbot, Atlantic halibut and spotted wolffish, *Anarhichas minor*. The system is almost a standard raceway, but with a very low water level (7 mm for fish at 100 mg, 25 cm for fish above 2 kg). The system is a package with some crucial preconditions. These include high fish density (often 100–500 kg m⁻³), no countercurrent in the levelled raceways (no jet currents), adjustment of water intake with the most remote fish in mind and feeding with floating pellets. Self-cleaning is easily obtained in the system, as fish movements along with the water current will transport excess feed and faeces to the outlet of the raceway. The system has been tested for a wide size range of raceways (0.07 – 80 m²) and fish sizes (2 mg to 10 kg), normally with growth and survival rates as good as with traditional rearing systems. There seems to be a “learning window”; the earlier the fish are introduced to shallow raceways, the better they perform. The results indicate that a variety of fish species can be produced in shallow raceways; these can be stacked in racks, which facilitate re-use of water from level to level. A very compact and cost-effective farming system will be the outcome (Øiestad, 1999).

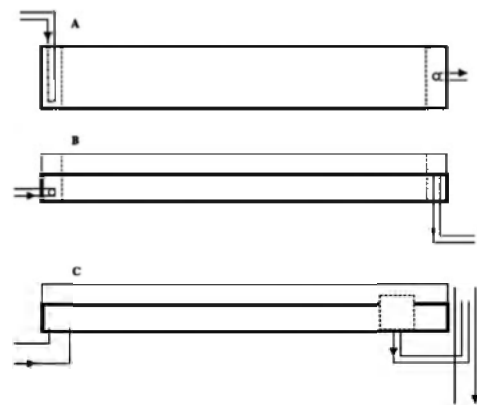

Figure 14. Principal drawing of a shallow raceway. (A) Seen from above with perforated inlet pipe and perforated screen limiting the fish chamber: screen in front of stand-pipe; (B) Same raceway seen as side view with level of water indicated by bold line; (C) Same view, but tanks without screens: inlet pipe in the bottom and outlet shielded by a perforated box and level dictated by an outside monk (from Øiestad, 1999).

Water quality aspects in intensive sole rearing

Production of sole in Northern Europe will take place in land-based facilities supplied with water pumped from depths of stable, optimal temperatures for the species or using heated seawater. An efficient exploitation of the water resources require detailed knowledge on the impact of water quality on fundamental production characteristics such as growth performance, food conversion efficiency and health status. Few studies have addressed the impact of a degraded water quality on the performance of sole. In intensive systems, i.e., shallow raceways in racks, where water may be reused between levels (Øiestad, 1999), fish densities may be higher than 500 kg m⁻³ (Øiestad, 1999), thus there will be a downstream gradual decrease in dissolved oxygen and pH, concurrent with a gradual accumulation of natural catabolites such as ammonia and carbon dioxide (Person-Le Ruyet et al., 1997a). These water parameters may separately or together affect production characteristics.

Ammonia is the main end product of nitrogen metabolism in teleosts (Foster and Goldstein, 1969), and it exists in both ionized (NH₄⁺) and unionized (NH₃) forms. The toxicity of ammonia to fish and other aquatic organisms is primarily attributed to the unionized (UIA) form, and in intensive reuse systems, ammonia concentrations may increase to levels that can cause reduced

Table 4. A review of the main trials in shallow raceways from 1988 to 1998 (adapted from Øiestad, 1999), with updated information on sole (Imstrand, unpublished results)

Species	Fish size	Raceway size in cm W × L × H ^a (min/max)	SGR (% day ⁻¹)	Density
Turbot	0.09–12 g	20 × 60 × 0.7 (min)	4.5–11	8–210%
	1–3 g	200 × 2000 × 10 (max)	4	200%
	7–13 g	40 × 360 × 3	1.7	100–300%
	200–320 g	40 × 360 × 5	0.3–1.6	15 kg m ⁻²
	146–800 g	200 × 300 × 10	0.8	100–200%
Atlantic halibut	1–8 kg	100 × 200 × 15		100–200%
	0.07–0.25 g	20 × 60 × 0.7 (min)	6	8–10%
California halibut	1–8 kg	400 × 2000 × 25 (max)	0.25–0.35	30–100%
	8–500 mg	7 × 200 × 2	12–20	30–60%
Sole	20–100 mg	20 × 60 × 1	–	–
	1–30 g	40 × 400 × 3	1.5–6.2	70–150%
Winter flounder	30–200 mg	40 × 400 × 2	–	–
Common wolffish	0.2–15 g	20 × 60 × 1 (min)	0.2–0.6	25–100%
	0.2–2.0 g	20 × 100 × 2	5–6	50–100%
	0.1–3 kg	200 × 300 × 10 (max)	–	50–100%
Spotted wolffish	0.2–2000 g	20 × 60 × 1 (min)	0.5–2.4	50–100%
	5–200 g	40 × 360 × 5	1.0–2.4	50–100%
	10 kg	200 × 2000 × 25 (max)	0.6	50–100%
Lumpsucker	1 mg–10 g	20 × 100 × 2–10	4	–
Atlantic cod	8 mg–10 g	40 × 200 × 2	1.5–3.5	25–220 kg m ⁻³
White seabass	2 mg–2 g	7 × 100 × 2 (min)	1–15	1–12 kg m ⁻³
	100 g	60 × 500 × 30 (max)	–	10 kg m ⁻³
Atlantic salmon	0.15–2 g	15 × 100 × 3 (min)	1.5–3.0	20–460 kg m ⁻³
	60 g	30 × 200 × 10 (max)	1.5–2.0	20–280 kg m ⁻³

^a Only water depth is indicated and not the tank height.

growth or even death (Person-Le Ruyet et al., 1997a). In addition to being highly toxic alone, ammonia interacts with oxygen, to become more toxic at low levels of DO (Lloyd, 1961; Alabaster et al., 1979; Thurston et al., 1981; Wajsbrot et al., 1991). Concurrent with a gradual decrease in oxygen content downstream in a raceway, there will also be an inversely correlated increase in carbon dioxide (CO₂) content, which in turn will reduce pH. Alderson (1979) investigated the interactive effects of pH and chronic ammonia exposure on growth in juvenile *S. solea* and estimated the NOEC (No-Observable-Effect-Concentration) of UIA to be 0.066 mg l⁻¹. Above this

level growth decreased in a linear manner with increasing concentrations of UIA. He also found that the different pH conditions used, ranging from 6.85 to 8.1, did not have any marked effect on this threshold limit. The UIA NOEC for sole is lower than that found for other flatfish species. Kim et al., (1997) estimated the NOEC for flounder, *Paralichthys olivaceus*, larvae to be 0.102 mg UIA l⁻¹ and in turbot juveniles the NOEC has been found to be even higher, ranging from 0.09 to 0.18 mg UIA l⁻¹ (Alderson, 1979; Rasmussen and Korsgaard, 1996; Person-Le Ruyet et al., 1997b). Parra and Yúfera (1999) investigated tolerance to ammonia and nitrite in

S. senegalensis larvae and found an UIA 24-h LC₅₀ value of 1.32 p.p.m. No mortality occurred when *S. senegalensis* larvae were exposed to nitrite concentrations of up to 2000 p.p.m. for 24 h. *S. senegalensis* proved to be more resistant than the simultaneously studied gilthead seabream, *Sparus aurata*, and the increased tolerance to ammonia and nitrite in sole was associated with a greater amount of mucus in their skin. In the work of Parra and Yúfera (2002), tolerance to water pH was investigated in *S. senegalensis* larvae. They found that low 24-h pHL₅₀ values ranged between 4.88 and 5.76, whereas high 24-h pHL₅₀ values ranged between 8.94 and 9.57.

Dissolved oxygen (DO) is, besides food and temperature, the most important factor controlling growth in fish, and a constant DO content below a critical level is considered to reduce food consumption, growth rate and food conversion efficiency (Jobling, 1994). The development of oxygen supplementation systems has alleviated some problems associated with low DO, but in a shallow raceway system, where fish densities may be extremely high, the reduction in DO content from inlet to outlet will be far greater than in a traditional tank system. In the natural environment, motile species can detect and avoid low levels of dissolved oxygen (DO) (Bejda et al., 1992), whereas in a culture facility, fish are inadvertently confined to the ambient DO levels determined by water-flow and fish biomass present. Significant effort has been put into determining threshold oxygen values for reduced growth rate and mortality in various cultured species (e.g., Bejda et al., 1992; Van den Thillart et al., 1994; Thetmeyer et al., 1999; Pichavant et al., 2000). Van den Thillart et al., (1994) investigated *S. solea* sensitivity to long-term hypoxia. They found that the resting metabolic rate and the scope for activity in the species showed significant changes at reduced oxygen levels. They suggested that the limiting O₂ level for *S. solea* was between 40% and 60% air saturation, while the incipient lethal level, indicated by the onset of anaerobic metabolism, was between 12% and 20%. Dalla Via et al. (1998) described the behavioural responses of sole to hypoxic conditions and concluded that escape behaviour and burst activity are induced as a last response when other energy-saving alternatives (anaerobic metabolism and metabolic depression) seem to become insufficient.

Conclusions

Research on sole culture has increased over the last decade, and has extended our current knowledge of the species and promoted renewed interest in the aquaculture of both species. As sole yet again is looked upon as promising aquaculture candidate, it is important to study the species in its natural environment, as optimal conditions in culture will try to mimic the optimal preferences of the species in nature. It seems clear that there are several biotic and abiotic mechanisms that act as structural forces in these species, and recent studies support the phylogenetic relatedness of *S. solea* and *S. senegalensis*, being found as closest sister lineages in most reconstructions. For both species, non-panmixia is indicated and examples of population specific life histories are found. Such population specific adaptation is important to utilize in culture as these differences will probably have a genetic basis and could be enhanced by genetic selection.

Studies on sole have clearly indicated that, in contrast to other cultured marine fishes, fingerling production is not the bottleneck in proceeding towards commercial culture. This is mastered at laboratory and pilot scale, but experience with upscaling is still lacking. In sole culture, there are still obstacles in the development of feeding and on-growing systems, which are mainly due to the peculiar feeding behaviour of this species. Sole requires on-growing facilities which are a compromise between self-cleaning capacity, feed residence time and feed distribution. Currently, there is no commercial feed which suits the needs of sole and the farming technique used available.

This review clearly indicates, that albeit there exists many unsolved problems and unanswered questions, sole remains a very attractive candidate for marine aquaculture and has a very big potential for future farming.

Acknowledgements

The work was funded by the EU Quality of Life and Management of Living Resources program (Q5CR-CT-2002-71039). The effort of an anonymous referee in improving previous versions of the manuscript is highly appreciated.

References

- Abd-El-Gawad, A.M., Abderrassoul, H.A., Bakhom, Sh.A. and Ragheb, E. (1997) Genetic distance based on electrophoretic isoenzymes of two sole species from Mediterranean Sea and Lake Qarun, Egypt. *Bull. Inst. Oceanogr. Fish., Cairo* **23**, 187–202.
- Aksnes, A., Hjertnes, T. and Opstvedt, J. (1996) Effect of dietary protein level on growth and carcass composition in Atlantic halibut (*Hippoglossus hippoglossus* L.). *Aquaculture* **145**, 225–233.
- Alabaster, J.S., Shurben, D.G. and Knowles, G. (1979) The effect of dissolved oxygen and salinity on the toxicity of ammonia to smolts of salmon, *Salmo salar* L. *J. Fish Biol.* **15**, 705–712.
- Alderson, R. (1979) The effect of ammonia on the growth of juvenile Dover sole, *Solea solea* (L.) and turbot, *Scophthalmus maximus* (L.). *Aquaculture* **17**, 291–309.
- Andersen, N.G. and Alsted, N.S. (1993) Growth and body composition of turbot (*Scophthalmus maximus*) in relation to different lipid/protein ratios in the diet. In: Kaushik, S.J. and Luquet, P. (eds.), *Fish Nutrition in Practice. Proceedings of the IV International Symposium Fish Nutrition and Feeding, Les Colloques 61*. INRA Editions, Paris, pp. 479–491.
- Anonymous (1999) *Fishery Statistics Capture Production Yearbook*. Food and Agriculture Organisation of the United Nations, Rome.
- Anonymous (2004) *ICES Catch Database*. International Council for Exploration of the Sea, Denmark. <http://www.fishbase.org/report/ICES/ICESearchMenu.cfm>.
- Appelbaum, S. (1985) Rearing of the dover sole, *Solea solea* (L.), through its larval stages using artificial diets. *Aquaculture* **49**, 209–221.
- Aragão, C. (1999) The effect of feeding rotifers at first feeding of *Solea senegalensis*. Working report, CCMAR, Universidade do Algarve, 4 pp.
- Aragão, C., Conceição, L.E.C., Dias, J., Marques, A.C., Gomes, E. and Dinis, M.T. (2003) Soy protein concentrate as a protein source for Senegalese sole (*Solea senegalensis* Kaup 1858) diets: effects on growth and amino acid metabolism of post-larvae. *Aquac. Res.* **34**, 1443–1452.
- Baudin-Laurencin, F. (1986) Sensitivity of the sole (*Solea solea*) to vibriosis. In: Vivares, C.P., Bonami, J.R. and Jaspers, E. (eds.), *Pathology in Marine Aquaculture*. European Aquaculture Society, Special Publication no. 9, Bredene, Belgium, pp. 345–350.
- Baynes, S.M. and Howell, B.R. (1993) Observations on the growth, survival and disease resistance of juvenile common sole, *Solea solea* (L.), fed *Mytilus edulis* L. *Aquac. Fish. Manage.* **24**, 95–100.
- Baynes, S.M. and Howell, B.R. (1996) The influence of egg size and incubation temperature on the condition of *Solea solea* (L.) larvae at hatching and first feeding. *J. Exp. Mar. Biol. Ecol.* **199**, 59–77.
- Baynes, S.M., Howell, B.R. and Beard, T.W. (1993) A review of egg production by captive sole, *Solea solea* (L.). *Aquac. Fish. Manage.* **24**, 171–180.
- Baynes, S.M., Howell, B.R., Beard, T.W. and Hallam, J.D. (1994) A description of spawning behaviour of captive Dover sole, *Solea solea* (L.). *Neth. J. Sea Res.* **32**, 271–275.
- Bedoui, R. (1995) Rearing of *Solea senegalensis* (Kaup, 1958) in Tunisia. *Cahier Options Mediterranee* **16**, 31–39.
- Bejda, A.J., Phelan, B.A. and Studholme, A.L. (1992) The effect of dissolved oxygen on growth of young-of-the-year winter flounder, *Pseudopleuronectes americanus*. *Environ. Biol. Fish.* **34**, 321–327.
- Ben-Tuvia, A. (1990) A taxonomic reappraisal of the Atlanto-Mediterranean soles *Solea solea*, *S. senegalensis* and *S. lascaris*. *J. Fish Biol.* **36**, 947–960.
- Berge, G.M. and Storebakken, T. (1991) Effect of dietary fat level on weight gain, digestibility and fillet composition of Atlantic halibut. *Aquaculture* **99**, 331–338.
- Bernadet, J.F., Campbell, A.C. and Buswell, J.A. (1990) *Flexibacter maritimus* is the agent of “black patch necrosis” in Dover sole in Scotland. *Dis. Aquat. Org.* **8**, 233–237.
- Boehlert, G.W. (1981) The effects of photoperiod and temperature on laboratory growth of juvenile *Sebastes diploproa* and a comparison with growth in the field. *Fish. Bull.* **79**, 789–794.
- Boeuf, G. and Le Bail, P.Y. (1999) Does light have an influence on fish growth? *Aquaculture* **177**, 129–152.
- Brett, J.R. (1979) Environmental factors and growth. In: Hoar, W.S., Randall, D.J. and Brett, J.R. (eds.), *Fish Physiology*, Vol. 8, Bioenergetics and Growth. Academic Press, New York, pp. 599–675.
- Bromley, P.J. (1977) Methods of weaning juvenile hatchery reared sole (*Solea solea* (L.)) from live food to prepared diets. *Aquaculture* **12**, 337–347.
- Cabral, H.N. (2000) Distribution and abundance patterns of flatfishes in the Sado Estuary, Portugal. *Estuaries* **23**, 351–358.
- Cabral, H. and Costa, M.J. (1999) Differential use of nursery areas within the Tagus Estuary by sympatric soles *Solea solea* and *Solea senegalensis*. *Environ. Biol. Fish.* **56**, 389–397.
- Cacerez-Martinez, C., Cadena-Roa, M. and Métailler, R. (1984) Nutritional requirements of turbot (*Scophthalmus maximus*): I. A preliminary study of protein and lipid utilization. *J. World Maric. Soc.* **15**, 191–202.
- Cadena-Roa, M., Huelvan, C., Le Borgne, Y. and Metailler, R. (1982) Use of rehydratable extruded pellets and attractive substances for the weaning of sole (*Solea vulgaris*). *J. World Maric. Soc.* **13**, 246–253.
- Cañavate, J.P. and Fernández-Díaz, C. (1999) Influence of co-feeding larvae with live and inert diets on weaning the sole *Solea senegalensis* onto commercial dry feeds. *Aquaculture* **174**, 255–263.
- Champalbert, G., Macquart-Moulin, C. and Howell, B. (1992) Influence of sediment on the settlement of larvae and juvenile sole, (*Solea solea* L.) in laboratory conditions. *Mar. Behav. Physiol.* **21**, 255–276.
- Champalbert, G., Marchand, J. and Campion, J.L. (1994) Rheotaxis in juvenile sole *Solea solea* (L.): influence of salinity and light conditions. *Neth. J. Sea Res.* **32**, 309–319.
- Coughlan, J.P., Imsland, A.K., Galvin, P.T., FitzGerald, R.D., Nævdal, G. and Cross, T.F. (1998) Microsatellite DNA variation in wild populations and farmed strains of turbot *Scophthalmus maximus* from Ireland and Norway. *J. Fish Biol.* **52**, 916–922.
- Coutteau, P., Robles, R. and Spruyt, W. (2001) Ongrowing feed for Senegal sole (*Solea senegalensis* Kaup). In: *Abstracts of Contribution Presented at the International Conference Aqua-*

- culture Europe 2001. Special Publication no. 29. European Aquaculture Society, pp. 58–59.
- Dalla Via, J., Van den Thillart, G., Cattani, O. and Cortesi, P. (1998) Behavioural responses and biochemical correlates in *Solea solea* to gradual hypoxic exposure. *Can. J. Zool.* **76**, 2108–2113.
- Danielssen, D.S. and Gulbrandsen, K.E. (1989) Growth rate of turbot (*Scophthalmus maximus* L.) and sole (*Solea solea* L.) based on dry pellets. *Aquaculture – A Biotechnol. Prog.* 631–636.
- Day, O.J., Howell, B.R. and Jones, D.A. (1997) The effect of dietary hydrolysed fish protein concentrate on the survival and growth of juvenile Dover sole, *Solea solea* (L.), during and after weaning. *Aquac. Res.* **28**, 911–921.
- Day, O.J., Howell, B.R., Aksnes, A. and Nygård, E. (1999) Recent advances in the weaning of sole, *Solea solea* (L.). In: *Abstracts of contributions presented at the International Conference Aquaculture Europe 1999*. Special Publication no. 27. European Aquaculture Society, pp. 40–41.
- Déniel, C. (1990) Comparative study of growth of flatfishes on the west coast of Brittany. *J. Fish Biol.* **37**, 149–166.
- Devauchelle, N., Alexandre, J.C., Le-Corre, N. and Letty, Y. (1987) Spawning of sole (*Solea solea*) in captivity. *Aquaculture* **66**, 125–147.
- Diakov, Y.P. (1998) Population structure of the Pacific black halibut *Reinhardtius matsuurae* Jordan et Snyder. *J. Sea Res.* **40**, 109–116.
- Dias, J., Alvarez, M.J., Diez, A., Arzel, J., Corraze, G., Bautista, J.M. and Kaushik, S.J. (1998) Regulation of hepatic lipogenesis by dietary protein/energy ratio in juvenile European seabass (*Dicentrarchus labrax*). *Aquaculture* **161**, 169–186.
- Dias, J., Rueda-Jasso, R., Panserat, S., Conceição, L.E.C., Gomes, E. and Dinis, M.T. (in press) Effect of dietary carbohydrate to lipid ratios on growth, lipid deposition and metabolic hepatic enzymes in juvenile Senegal sole (*Solea senegalensis*). *Aquac. Res.*
- Dinis, M.T. (1986). Quatre soleidae de l'estuaire du Tage. Reproduction et croissance. Essai d'élevage de *Solea senegalensis* Kaup. Thèse de Doctorat *Æs-Sciences Naturelles*, Université de Bretagne Occidentale, Brest, 348 pp.
- Dinis, M.T. (1992) Aspects of the potential of *Solea senegalensis* Kaup for aquaculture: larval rearing and weaning to an artificial diet. *Aquac. Fish. Manage.* **23**, 515–520.
- Dinis, M.T., Reis, J. and Arrobas, J. (1996) Evaluation of the farming potential for *Solea senegalensis* Kaup, a new species for aquaculture in the Mediterranean area. In: *Book of Abstracts World Aquaculture 1996*, Bangkok, pp. 107–109.
- Dinis, M.T., Ribeiro, L., Soares, F. and Sarasquete, C. (1999) A review on the cultivation potential of *Solea senegalensis* in Spain and in Portugal. *Aquaculture* **176**, 27–38.
- Dinis, M.T., Ribeiro, L., Conceição, L.E.C. and Aragão, C. (2000) Larvae digestion and new weaning experiments in *Solea senegalensis*. *Cahiers Options Méditerranéennes* **47**, 193–204.
- Dinis, M.T., Soares, F., Ribeiro, L., Engrola, S., Cação, P., Aragão, C., Pousão-Ferreira, P. and Conceição, L.E.C. (2003) Broodstock management and larval rearing of Senegalese sole (*Solea senegalensis*). In: *Book of Abstracts of the World Aquaculture 03*, Salvador, Brazil, 19 May–23 May 2003.
- Engrola, S., Cação, P., Conceição, L.E.C. and Dinis, M.T. (2001) Ongrowing of Senegal sole (*Solea senegalensis*) juveniles at different densities. In: *Book of Abstracts of the Aquaculture 2001 WAS Conference*, January 21–25, Lake Buena Vista, Florida, USA.
- Engrola, S., Conceição, L.E.C., Pereira, R. and Dinis, M.T. (2002) Growth and diet utilisation of sole, *Solea senegalensis* reared under different feeding regimes. In: *Book of Abstracts of the 10th International Symposium on Nutrition and Feeding in Fish*, 2–7 June 2002, Rhodes, Greece.
- Engrola, S., Conceição, L.E.C., Gavaia, P.J., Cancela, M.L. and Dinis, M.T. (in press) Effect of pre-weaning feeding regime on weaning success of Senegal sole, *Solea senegalensis* (Kaup, 1858). *Aquaculture*.
- Evans, D.H. (1984) The roles of gill permeability and transport mechanisms in euryhalinity. In: Hoar, W.S. and Randall, D.J. (eds.), *Fish Physiology*, Vol. 10(B). Academic Press, New York, pp. 239–283.
- Exadactylos, A., Geffen, A.I. and Thorpe, J.P. (1998) Population structure of the Dover sole, *Solea solea* L., in a background of high gene flow. *J. Sea Res.* **40**, 117–129.
- Exadactylos, A., Geffen, A.I. and Thorpe, J.P. (1999) Growth and genetic variation in hatchery-reared larval and juvenile Dover sole, *Solea solea* (L.). *Aquaculture* **179**, 209–226.
- Fairbairn, D.J. (1981) Which witch is which? A study of the stock structure of witch flounder (*Glyptocephalus cynoglossus*) in the Newfoundland region. *Can. J. Fish. Aquat. Sci.* **38**, 782–794.
- Fehri-Bedoui, R., Dinis, M.T. and Maamouri, F. (2000) Étude histologique du développement de l'appareil digestif et de la vessie gazeuse de la sole *Solea senegalensis* (Soleidae). *Cybium* **24**, 343–358.
- Fernández-Díaz, C. and Yúfera, M. (1997) Detecting growth in gilthead seabream, *Sparus aurata* L., larvae fed microcapsules. *Aquaculture* **153**, 93–102.
- Flüchter, J. (1979) Identification and treatment of diseases in the common sole (*Solea solea* L.). *Aquaculture* **16**, 271–274.
- Fonds, M. (1976) The influence of temperature and salinity on growth of young sole *Solea solea* L. *10th Eur. Symp. Mar. Biol.* **1**, 109–125.
- Fonds, M. (1979a) Laboratory observations on the influence of temperature and salinity on development of the eggs and growth of the larvae of *Solea solea* (Pisces). *Mar. Ecol. Prog. Ser.* **1**, 91–99.
- Fonds, M. (1979b) A seasonal fluctuation in growth rate of young plaice (*Pleuronectes platessa*) and sole (*Solea solea*) in the laboratory at constant temperatures and a natural daylight cycle. In: Naylor, E. and Hartnoll, R.G. (eds.), *Cyclic Phenomena in Marine Plants and Animals. Proceedings of the 13th European Marine Biology Symposium*. Pergamon Press, Oxford, pp. 151–156.
- Foss, A., Imsland, A.K. and Nævdal, G. (1998) Population genetics studies of Atlantic halibut in the North Atlantic Ocean. *J. Fish Biol.* **52**, 901–905.
- Foster, R.P. and Goldstein, L. (1969) Formation of excretory products. In: Hoar, W.S. and Randall, D.J. (eds.), *Fish Physiology*, Vol. 1. Academic Press, New York, pp. 313–350.
- Fuchs, J. (1978) Effect of photoperiod on growth and survival during rearing of larvae and juveniles of sole (*Solea solea*). *Aquaculture* **15**, 63–74.

- Fuchs, J. (1982) The production of juvenile sole (*Solea solea*) under intensive conditions. 1. The first month of rearing. *Aquaculture* **26**, 321–337.
- Gatesoupe, F.J. (1983) Weaning of sole, *Solea solea*, before metamorphosis achieved with high growth and survival rates. *Aquaculture* **32**, 401–404.
- Gatesoupe, F.J. and Luquet, P. (1982) Weaning of the sole (*Solea solea*) before metamorphosis. *Aquaculture* **26**, 359–368.
- Gavaia, P.J., Dinis, M.T. and Cancela, M.L. (2002) Osteological development and abnormalities of the vertebral column and caudal skeleton in larval and juvenile stages of hatchery-reared Senegal sole (*Solea senegalensis*). *Aquaculture* **211**, 305–323.
- Girin, M. (1979) Production methods of juveniles of three marine fishes: the sea-bass (*Dicentrarchus labrax*), the sole (*Solea solea*) and the turbot (*Scophthalmus maximus*). *Rapport Sci. Tech. CNEOX* **39**, 202 p.
- Grant, W.S., Teel, D.J., Kobayashi, T., and Schmitt, C. (1984) Biochemical population genetics of Pacific halibut (*Hippoglossus stenolepis*) and comparison with Atlantic halibut (*H. hippoglossus*). *Can. J. Fish. Aquat. Sci.* **41**, 1083–1088.
- Greer Walker, M. and Emerson, L. (1990) The seasonal migration of soles (*Solea solea*) through the Dover strait. *Neth. J. Sea Res.* **25**, 417–422.
- Grotmol, S., Totland, G.K., Thorud, K. and Hjeltnes, B.K. (1997) Vacuolating encephalopathy and retinopathy associated with a nodavirus-like agent: a probable cause of mass mortality of cultured larval and juvenile Atlantic halibut. *Dis. Aquat. Org.* **29**, 85–97.
- Guillaume, J., Coustans, M., Métailler, R., Person-Le Ruyet, J. and Robin, J. (1991) Flatfish, turbot, sole and plaice. In: Wilson, R.P. (ed.), *Handbook of Nutrient Requirements of Finfish*. CRC Press, Boca Raton, Florida, pp. 77–82.
- Hart, P.R., Hutchinson, W.G. and Purser, G.J. (1996) Effects of photoperiod, temperature and salinity on hatchery-reared larvae of the greenback flounder (*Rhombosolea tapirina* Günther, 1862). *Aquaculture* **144**, 303–311.
- Heap, S.P. and Thorpe, J.P. (1987) A preliminary study of comparative growth rates in 0-group malpigmented and normally pigmented turbot, *Scophthalmus maximus* (L.), and turbot-brill hybrids, *S. maximus* × *S. rhombus* (L.), at two temperatures. *Aquaculture* **60**, 251–264.
- Helland, S.J. and Grisdale-Helland, B. (1998) Growth, feed utilization and body composition of juvenile Atlantic halibut (*Hippoglossus hippoglossus*) fed diets differing in the ratio between the macronutrients. *Aquaculture* **166**, 49–56.
- Hemre, K., Opstad, I., Espe, M., Solbakken, J., Hemre, G.I. and Pittman, K. (2002) Nutrient composition and metamorphosis success of Atlantic halibut (*Hippoglossus hippoglossus* L.) larvae fed natural zooplankton or Artemia. *Aquac. Nutr.* **8**, 139–148.
- Hoarau, G., Rijnsdorp, A.D., van der Veer, H.W., Stam, W.T. and Olsen, J.L. (2002) Population structure of plaice (*Pleuronectes platessa* L.) in northern Europe: microsatellites revealed large-scale spatial and temporal homogeneity. *Molecul. Ecol.* **11**, 1165–1176.
- Houghton, R.G., Last, J.M. and Bromley, P.J. (1985) Fecundity and egg size of sole (*Solea solea* (L.)) spawning in captivity. *Journal du Conseil International pour l'Exploration de la Mer* **42**, 162–165.
- Howell, B.R. (1973) Marine fish culture in Britain VIII. A marine rotifer, *Brachionus plicatilis* Muller, and the larvae of the mussel, *Mytilus edulis* L., as foods for larval flatfish. *Journal du Conseil International pour l'Exploration de la Mer* **32**, 385–394.
- Howell, B.R. (1997) A re-appraisal of the potential of the sole, *Solea solea* (L.), for commercial cultivation. *Aquaculture* **155**, 359–369.
- Howell, B.R. (1998) The effect of stocking density on growth and size variation in cultured turbot, *Scophthalmus maximus*, and sole *Solea solea*. *ICES CM* **1998/L:10**.
- Howell, B.R. and Tzoumas, T.S. (1991) The nutritional value of *Artemia* nauplii for larval sole, *Solea solea* (L.), with respect to their (n-3) HUFA content. In: Lavens, P., Sorgeloos, P., Jaspers, E. and Ollevier, F. (eds.), *Larvi '91 – Fish and Crustacean Larviculture Symposium*. Special Publication no. 15, European Aquaculture Society, Gent, Belgium, pp. 63–65.
- Imsland, A.K. and Jonassen, T.M. (2001) Regulation of growth in turbot (*Scophthalmus maximus* Rafinesque) and Atlantic halibut (*Hippoglossus hippoglossus* L.): aspects of environment × genotype interactions. *Rev. Fish Biol. Fisheries.* **11**, 71–90.
- Imsland, A.K., Folkvord, A. and Stefansson, S.O. (1995) Growth, oxygen consumption and activity of juvenile turbot (*Scophthalmus maximus* L.) reared under different temperatures and photoperiods. *Neth. J. Sea Res.* **34**, 149–159.
- Imsland, A.K., Sunde, L.M., Folkvord, A. and Stefansson, S.O. (1996) The interaction between temperature and size on growth of juvenile turbot. *J. Fish Biol.* **49**, 926–940.
- Imsland, A.K., Folkvord, A., Jónsdóttir, Ó.D.B. and Stefansson, S.O. (1997) Effects of exposure to extended photoperiods during the first winter on long-term growth and age at first maturity in turbot (*Scophthalmus maximus*). *Aquaculture* **159**, 125–141.
- Imsland, A.K., Foss, A., Gunnarsson, S., Berntssen, M., FitzGerald, R., Bonga, S.W., van Ham, E., Nævdal, G. and Stefansson, S.O. (2001) The interaction of temperature and salinity on growth and food conversion in juvenile turbot (*Scophthalmus maximus*). *Aquaculture* **198**, 353–367.
- Imsland, A.K., Foss, A., Bonga, S.W., van Ham, E. and Stefansson, S.O. (2002) Comparison of growth and RNA/DNA ratios in three populations of juvenile turbot reared at two salinities. *J. Fish Biol.* **60**, 288–300.
- Imsland, A.K., Dragsnes, M. and Stefansson, S.O. (2003a) Exposure to continuous light inhibits maturation in turbot (*Scophthalmus maximus*). *Aquaculture* **219**, 911–919.
- Imsland, A.K., Scanu, G. and Nævdal, G. (2003b) New variants of the hemoglobin of turbot: possible use in aquaculture and population genetics studies. *Sarsia* **88**, 55–64.
- Irvin, D.N. (1973) The growth and survival of Dover sole, *Solea solea*, and some observations on the growth of the plaice *Pleuronectes platessa*, considered at various temperatures. PhD thesis, University of Liverpool, 186 pp.
- Jobling, M. (1994) *Fish Bioenergetics*. Chapman and Hall, London, 309 pp.
- Jonassen, T.M., Imsland, A.K. and Stefansson, S.O. (1999) The interaction of temperature and size on growth of juvenile Atlantic halibut. *J. World Aquac. Soc.* **54**, 556–572.

- Jonassen, T.M., Imsland, A.K., Kadowaki, S. and Stefansson, S.O. (2000) Interaction of temperature and photoperiod on growth of Atlantic halibut, *Hippoglossus hippoglossus* L. *Aquac. Res.* **31**, 219–227.
- Kamstra, A., van den Briel, V., van der Vorst, J. and de Wilde, J. (2001) Farming of sole (*Solea solea*) in recirculation systems; prospects and constraints. In: *Abstracts of Contributions Presented at the International Conference Aquaculture Europe 2001*. Special Publication no. 29. European Aquaculture Society, pp. 127–128.
- Kim, H-S., Kim, H-Y. and Chin, P. (1997) Effects of ammonia on survival and growth of the flounder larva, *Paralichthys olivaceus*. *J. Korean Fish. Soc.* **30** (abstract only).
- Kotoulas, G., Bonhomme, F. and Borsa, P. (1995) Genetic structure of the common sole *Solea vulgaris* at different geographical scales. *Mar. Biol.* **122**, 361–375.
- Knutsen, J.A. (1992) Feeding behaviour of North Sea turbot (*Scophthalmus maximus*) and Dover sole (*Solea solea*) larvae elicited by chemical stimuli. *Mar. Biol.* **113**, 543–548.
- Lenzi, M. and Salvatori, R. (1989) Management of a module for sole eggs production. In: De Pauw, N., Jaspers, E., Ackefors, H. and Wilkins, N. (eds.), *Aquaculture: A Biotechnology in Progress. Proceedings of the Aquaculture Europe 1987 Conference*. European Aquaculture Society, Bredene, Belgium, 549 pp.
- Lloyd, R. (1961) Effect of dissolved oxygen concentration on the toxicity of several poisons to rainbow trout (*Salmo gairdneri* Richardson). *J. Exp. Biol.* **38**, 447–455.
- Magalhães, N.M. (1997) Efeito de diferentes regimes alimentares no estado de condição de larvas de *Solea senegalensis* (Kaup, 1858). Master thesis in Aquaculture, Universidade do Algarve, 43 pp.
- Marteinsdóttir, G. and Begg, G.A. (2002) Essential relationships incorporating the influence of age, size and condition on variables required for estimation of reproductive potential in Atlantic cod *Gadus morhua*. *Mar. Ecol. Prog. Ser.* **235**, 235–256.
- McVicar, A.H. and White, P.G. (1979) Fin and skin necrosis of cultivated Dover sole, *Solea solea*. *J. Fish Dis.* **2**, 557–562.
- McVicar, A.H. and White, P.G. (1982) The prevention and cure of infectious disease in cultivated juvenile Dover sole, *Solea solea* (L.). *Aquaculture* **26**, 213–222.
- Médale, F., Brauge, C., Vallée, F. and Kaushik, S.J. (1995) Effects of dietary protein/energy ratio, ration size, dietary energy source and water temperature on nitrogen excretion in rainbow trout. *Water Sci. Technol.* **31**, 185–194.
- Métailler, R., Cadena-Roa, M. and Person-Le-Ruyet, J. (1983) Attractive chemical substances for the weaning of Dover sole (*Solea vulgaris*): qualitative and quantitative approach. *J. World Maric. Soc.* **14**, 679–684.
- Norberg, B., Weltzien, F.A., Karlsen, Ø. and Holm, J.C. (2001) Effects of photoperiod on sexual maturation and somatic growth in male Atlantic halibut (*Hippoglossus hippoglossus* L.). *Comp. Biochem. Physiol.* **129B**, 357–365.
- Øiestad, V. (1999) Shallow raceways as a compact, resource-maximizing farming procedure for marine fish species. *Aquac. Res.* **30**, 831–840.
- Parra, G. and Yúfera, M. (1999) Tolerance response to ammonia and nitrite exposure in larvae of two marine fish species (gilthead seabream *Sparus aurata* L. and Senegal sole *Solea senegalensis* Kaup). *Aquac. Res.* **30**, 857–863.
- Parra, G. and Yúfera, M. (2002) Tolerance response to water pH in larvae of two marine fish species, gilthead seabream, *Sparus aurata* (L.) and Senegal sole, *Solea senegalensis* (Kaup), during development. *Aquac. Res.* **33**, 747–752.
- Perez-Prieto, S., Garcia-Rosado, E., Rodriguez, S., Castro, S. and Borrego, J.J. (2001) Antigenic properties and experimental transmission to several fish species of a marine birnavirus isolated from sole (*Solea senegalensis*). *Vet. Microbiol.* **82**, 11–25.
- Person-Le Ruyet, J., Delbard, C., Chartois, H. and Le Delliou, H. (1997a) Toxicity of ammonia to turbot juveniles: I. effects on survival, growth and food utilisation. *Aquat. Liv. Resourc.* **10**, 307–314.
- Person-Le Ruyet, J., Galland, R., Le Roux, A. and Chartois, H. (1997b) Chronic ammonia toxicity in juvenile turbot (*Scophthalmus maximus*). *Aquaculture* **154**, 155–171.
- Pichavant, K., Person-Le-Ruyet, J., Le Bayon, N., Sévère, A., Le Roux, A., Quéméner, L., Maxime, V., Nonotte, G. and Boeuf, G. (2000) Effects of hypoxia on growth and metabolism of juvenile turbot. *Aquaculture* **188**, 103–114.
- Pousão-Ferreira, P., Machado, M. and Fonseca, L. (1995) Marine pond culture in southern Portugal: present status and future perspectives. *Cahiers Options Méditerranéennes* **16**, 21–30.
- Ramos, J. (1986a) Luteinizing hormone-releasing hormone analogue (LH-RHa) induces precocious ovulation in common sole (*Solea solea* L.). *Aquaculture* **54**, 185–190.
- Ramos, J. (1986b) Induction of spawning in common sole (*Solea solea* L.) with human chorionic gonadotropin (HCG). *Aquaculture* **56**, 239–242.
- Rasmussen, R.S. and Korsgaard, B. (1996) The effect of external ammonia on growth and food utilization of juvenile turbot (*Scophthalmus maximus* L.). *J. Exp. Mar. Biol. Ecol.* **205**, 35–48.
- Regost, C., Arzel, J., Cardinal, M., Robin, J., Laroche, M. and Kaushik, S.J. (2001) Dietary lipid level, hepatic lipogenesis and flesh quality in turbot (*Psetta maxima*). *Aquaculture* **193**, 291–309.
- Ribeiro, L., Sarasquete, C. and Dinis, M.T. (1999a) Histological and histochemical development of the digestive system of *Solea senegalensis* (Kaup, 1858) larvae. *Aquaculture* **171**, 293–308.
- Ribeiro, L., Zambonino-Infante, J.L., Cahu, C. and Dinis, M.T. (1999b) Development of digestive enzymes in larvae of *Solea senegalensis*, Kaup, 1858. *Aquaculture* **179**, 465–473.
- Rijnsdorp, A.D., Van Beek, F.A., Flatman, S., Millner, R.N., Riley, J.D., Giret, M. and de Clerck, R. (1992) Recruitment of sole stocks, *Solea solea* (L.), in the northeast Atlantic. *Neth. J. Sea Res.* **29**, 173–192.
- Rodríguez, R.B. (1984). Biología e cultivo de *Solea senegalensis* Kaup en Golfo de Cadiz. PhD Thesis, Universidad de Sevilla, 207 pp.
- Rodríguez, R.B. and Pascual, E. (1982) Effect of dried tuna pituitary on maturation and spawning in *Solea senegalensis* and *Sparus aurata*, and comparison with carp dried pituitary and HGG treatments. *Inf. Tecn. Inst. Invest. Pesq. Barc.* no **97**, 97 pp.
- Rodríguez, A. and Pascual, E. (1982) Primeros ensayos sobre utilización de la hipófisis del atún (*Thunnus thynnus*) en la maturation y puesta de *Solea senegalensis* e *Sparus aurata*. *Inv. Pesq.* **97**, 1–11.

- Rodriguez, S., Vilas, M.P., Gutierrez, M.C., Perez-Prieto, S.I., Sarasquete, M.C. and Rodriguez, R.B. (1997) Isolation and preliminary characterization of a birnavirus from the sole *Solea senegalensis* in southwest Spain. *J. Aquat. Anim. Health* **9**, 295–300.
- Rogers, S.I. (1994) Population density and growth rate of juvenile sole *Solea solea* (L.). *Neth. J. Sea Res.* **32**, 353–360.
- Rønnestad, I., Conceição, L.E.C., Aragão, C. and Dinis, M.T. (2000) Free amino acids are absorbed faster and assimilated more efficiently than protein in postlarval Senegal sole (*Solea senegalensis*). *J. Nutr.* **130**, 2809–2812.
- Rønnestad, I., Conceição, L.E.C., Aragão, C. and Dinis, M.T. (2001) Assimilation and catabolism of dispensable and indispensable free amino acids in post-larval Senegal sole (*Solea senegalensis*). *Comp. Biochem. Physiol.* **130C**, 461–466.
- Rueda-Jasso, R., Conceição, L.E.C., Dias, J., De Coen, W., Gomes, E., Rees, J.F., Soares, F., Dinis, M.T. and Sorgeloos, P. (in press) Effect of dietary non-protein energy levels on condition and oxidative status of Senegalese Sole (*Solea senegalensis*) juveniles. *Aquaculture*.
- Sarasquete, C., Gisbert, E., Ribeiro, L., Vieira, L. and Dinis, M.T. (2001) Glycogenates in epidermal branchial and digestive mucous cells and gastric glands of Gilthead Seabream, *Sparus aurata*, Senegales sole, *Solea senegalensis* and Siberian sturgeon, *Acipenser baeri* larvae. *Eur. J. Histochem.* **45**, 267–278.
- Simensen, L.M., Jonassen, T.M., Imsland, A.K. and Stefansson, S.O. (2000) Photoperiod regulation of growth of juvenile halibut (*Hippoglossus hippoglossus* L.) reared at different photoperiods. *Aquaculture* **119**, 119–128.
- Solbakken, V.A., Hansen, T. and Stefansson, S.O. (1994) Effects of photoperiod and temperature on growth and parr-smolt transformation in Atlantic salmon (*Salmo salar*) and subsequent performance in seawater. *Aquaculture* **121**, 13–27.
- Starkey, W.G., Ireland, J.H., Muir, K.F., Jenkins, M.E., Roy, W.J., Richards, R.H. and Ferguson, H.W. (2001) Nodavirus infection in Atlantic cod and Dover sole in the UK. *Vet. Rec.* **146**, 179–181.
- Stefansson, S.O., Nævdal, G. and Hansen, T. (1989) The influence of three unchanging photoperiods on growth and parr-smolt transformation in Atlantic salmon, *Salmo salar* L. *J. Fish Biol.* **35**, 237–247.
- Stefansson, S.O., Björnsson, B.Th., Hansen, T., Haux, C., Taranger, G.L. and Saunders, R.L. (1991) Growth, parr-smolt transformation, and changes in growth hormone of Atlantic salmon (*Salmo salar*) reared under different photoperiods. *Can. J. Fish. Aquat. Sci.* **48**, 2100–2108.
- Thetmeyer, H., Waller, U., Black, K.D., Inselman, S. and Rosenthal, H. (1999) Growth of European sea bass (*Dicentrarchus labrax* L.) under hypoxic and oscillating oxygen conditions. *Aquaculture* **174**, 355–367.
- Thurston, R.V., Russo, R.C. and Vinogradov, G.A. (1981) Ammonia toxicity to fishes. Effect of pH on the toxicity of the un-ionized ammonia species. *Environ. Sci. Technol.* **15**, 837–840.
- Tinti, F. and Picinetti, C. (2000) Molecular systematics of the Atlanto-Mediterranean *Solea* species. *J. Fish Biol.* **56**, 604–614.
- Urban, H.J. (1991) Reproductive strategies of North Sea plaice, *Pleuronectes platessa*, and North Sea sole *Solea solea*: batch spawning cycle and batch fecundity. *Meeresforschung* **33**, 330–339.
- Van den Thillart, G., Dalla Via, J., Vitali, G. and Cortesi, P. (1994) Influence of long-term hypoxia exposure on the energy metabolism of *Solea solea*. I. Critical O₂ levels for aerobic and anaerobic metabolism. *Mar. Ecol. Prog. Ser.* **104**, 109–117.
- Vázquez, R., Gonzalez, S., Rodriguez, A. and Mourente, G. (1994) Biochemical composition and fatty acid content of fertilized eggs, yolk sac stage larvae and first-feeding larvae of the Senegal sole (*Solea senegalensis* Kaup). *Aquaculture* **119**, 273–286.
- Wajsbrodt, N., Gasith, A., Krom, M.D. and Popper, D.M. (1991) Acute toxicity of ammonia to juvenile gilthead seabream *Sparus aurata* under reduced oxygen levels. *Aquaculture* **92**, 277–288.
- Woiwode, J.G. and Adelman I.R. (1991) Effects of temperature, photoperiod, and ration size on growth of hybrid striped bass X white bass. *Trans. Am. Fish. Soc.* **120**, 217–229.
- Yúfera, M., Sarasquete, M.C. and Fernández-Díaz, C. (1996) Testing protein-walled microcapsules for the rearing of first-feeding gilthead seabream, *Sparus aurata* L., larvae. *Mar. Freshwat. Res.* **47**, 211–216.
- Yúfera, M., Parra, G., Santiago, R. and Carrascosa, M. (1999) Growth, carbon, nitrogen and caloric content of *Solea senegalensis* (Pisces: Soleidae) from egg fertilization to metamorphosis. *Mar. Biol.* **134**, 43–49.
- Zadunaisky, J.A. (1984) The chloride cell: the active transport of chloride and the paracellular pathways. In: Hoar, W.S. and Randall, D.J. (eds.), *Fish Physiology*, Vol. 10B, Ion and Water Transport. Academic Press, New York, pp. 130–176.
- Zorrilla, I., Balebona, M.C., Moriñigo, M.A., Sarasquete, C. and Borrego, J.J. (1999) Isolation and characterization of the causative agent of pasteurellosis, *Photobacterium damsela* ssp. *piscicida*, from sole, *Solea senegalensis* (Kaup). *J. Fish Dis.* **22**, 167–172.
- Zorrilla, I., Arijó, S., Chabrilion, M., Diaz, P., Martínez-Manzanares, E., Balebona, M.C. and Moriñigo, M.A. (2003) *Vibrio* species isolated from diseased farmed sole, *Solea senegalensis* (Kaup), and evaluation of the potential virulence role of their extracellular products. *J. Fish Dis.* **26**, 103–108.